

RIVERBEND INDUSTRIAL PARK

LOCATED IN THE WEST HALF OF SECTION 10,
TOWNSHIP 1 SOUTH, RANGE 1 WEST,
SALT LAKE BASE AND MERIDIAN.

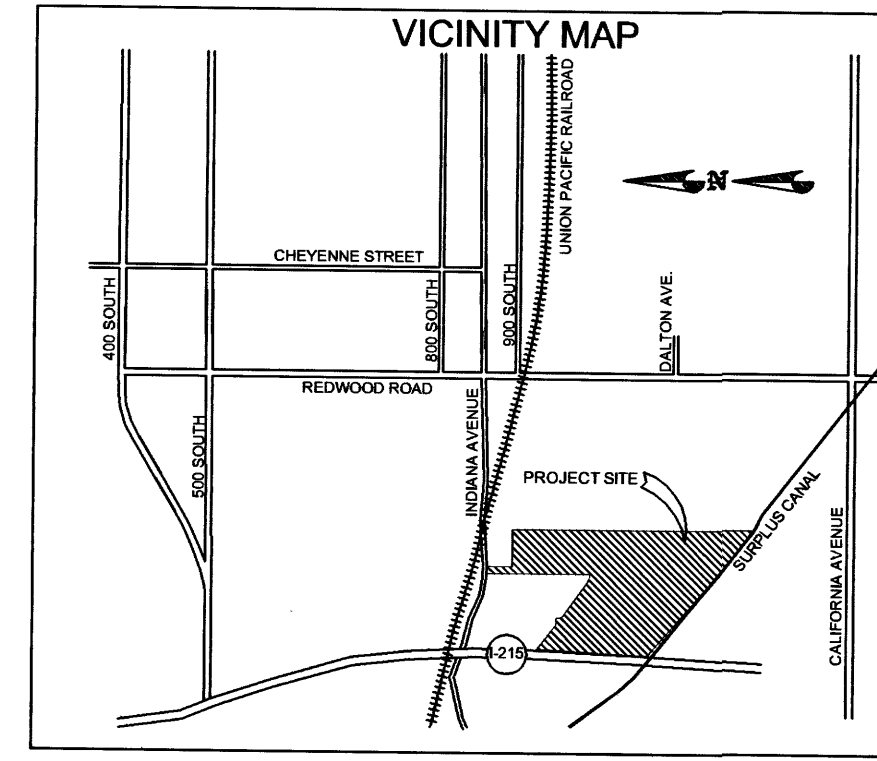
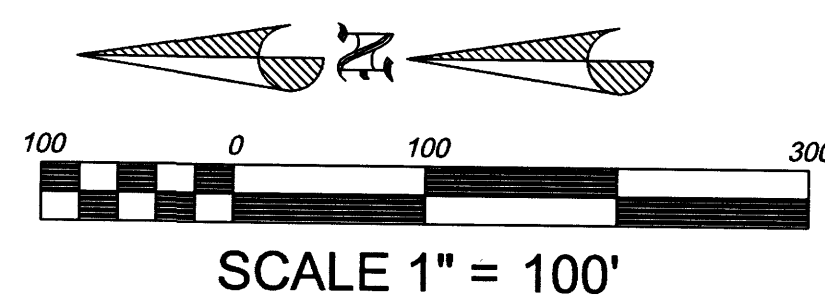

SURVEYOR'S CERTIFICATE:
I, ERIC D. ROBINS, DO HEREBY CERTIFY THAT I AM A REGISTERED LAND SURVEYOR, AND THAT I HOLD CERTIFICATE NO. 5152671 AS PRESCRIBED BY THE LAWS OF THE STATE OF UTAH. I FURTHER CERTIFY THAT BY THE AUTHORITY OF THE OWNERS, I HAVE MADE A SURVEY OF THE TRACT OF LAND SHOWN ON THIS MAP, AND THAT THE SAME HAS BEEN CORRECTLY SURVEYED AS SHOWN ON THIS MAP.

PROFESSIONAL LAND SURVEYOR
ERIC D. ROBINS
No. 5152671

BOUNDARY DESCRIPTION:
BEGINNING AT A POINT ON THE SOUTH LINE OF INDIANA AVENUE, SAID POINT BEING N00°02'47" W 1257.59 FEET AND N89°53'18" E 893.31 FEET FROM THE WEST QUARTER CORNER OF SECTION 10, TOWNSHIP 1 SOUTH, RANGE 1 WEST, SALT LAKE BASE AND MERIDIAN; AND RUNNING THENCE N89°53'18" E 66.00 FEET ALONG SAID SOUTH LINE OF INDIANA AVENUE; THENCE S00°02'47" E 241.35 FEET; THENCE N89°56'18" E 364.64 FEET TO THE SIXTEENTH LINE; THENCE ALONG SAID SIXTEENTH LINE S00°03'59" W 2326.60 FEET TO THE NORTH LINE OF THE SURPLUS CANAL; THENCE ALONG SAID NORTH LINE OF THE SURPLUS CANAL THE FOLLOWING THREE (3) COURSES: (1) N54°33'02" W 267.39 FEET (2) 173.22 FEET ALONG THE ARC OF A 1870.35 FOOT RADIUS CURVE TO THE RIGHT (CHORD BEARS N51°53'51" W 173.16 FEET) (3) N49°14'39" W 1138.46 FEET MORE OR LESS TO THE EAST RIGHT OF WAY LINE OF INTERSTATE 215; THENCE ALONG SAID RIGHT OF WAY LINE FOR INTERSTATE 215 N02°42'32" E 1081.51 FEET MORE OR LESS TO THE CENTERLINE OF THE CWA NO. 1 DITCH; THENCE ALONG SAID CENTERLINE THE FOLLOWING TWO (2) COURSES: (1) N51°32'30" E 699.11 FEET (2) 216.42 FEET ALONG THE ARC OF A 573.15 FOOT RADIUS CURVE TO THE LEFT (CHORD BEARS S62°21'29" E 215.14 FEET); THENCE N00°02'47" W 1016.58 FEET TO THE POINT OF BEGINNING. CONTAINING 41.95 ACRES, MORE OR LESS.

BASIS OF BEARINGS:
THE BASIS OF BEARINGS FOR THIS SURVEY IS S 89°53'18" W BETWEEN A FOUND SLC MONUMENT AT THE INTERSECTION OF REDWOOD AND INDIANA AVE AND A FOUND SLC MONUMENT IN INDIANA AVE AT ORANGE ST.

NARRATIVE OF BOUNDARY:
THE PURPOSE OF THIS SURVEY WAS TO DETERMINE AND MONUMENT THE BOUNDARY FOR THE DESCRIBED PARCELS. A SECTION BREAKDOWN OF SECTION 10 WAS PERFORMED USING THE AVAILABLE MONUMENTS FOUND BY THE EASTERLY BOUNDARY WAS HELD ALONG THE QUARTER SECTION LINE FROM SAID SECTION BREAKDOWN. THE SOUTHERLY BOUNDARY WAS HELD BY USING BOTH THE LEGAL DESCRIPTION AND BEST KNOWN HISTORICAL DATA FOR THE SURPLUS CANAL. THE BEARINGS AND DISTANCES ALONG THE WESTERLY BOUNDARY ARE A BEST FIT TO THE EVIDENCE FOUND IN THE FIELD. THIS IS DUE TO THE INCOMPLETE DATA FOUND ON THE DRAWINGS FROM UDOT FOR I-215. THE NORTHERLY BOUNDARY RUNS ALONG THE CWA CANAL AS LOCATED IN THE FIELD. NO LEGAL DESCRIPTIONS WERE FOUND FOR THE PART RUNNING THROUGH THE PARCEL. INFORMATION FOUND EAST OF THE PROPERTY AND A SURVEY PERFORMED BY REDCON WERE USED TO DETERMINE THE NORTH LINE OF THE NORTHERLY BOUNDARY LINE ALONG INDIANA WAS HELD TO MATCH THE REALIGNMENT PLAT FOUND AT THE SALT LAKE COUNTY RECORDERS OFFICE.

OWNER'S DEDICATION
THE UNDERSIGNED, BEING THE OWNER(S) OF THE ABOVE DESCRIBED TRACT OF LAND HAVING CAUSED THE SAME TO BE SUBDIVIDED INTO LOTS, STREETS, AND EASEMENTS, DO HEREBY DEDICATE ALL STREETS AND EASEMENTS SHOWN ON THIS PLAT HEREAFTER KNOWN AS THE **RIVERBEND INDUSTRIAL PARK** TO SALT LAKE CITY CORPORATION. THE UNDERSIGNED HEREBY WARRANT, DEFEND, AND SAVE THE CITY HARMLESS AGAINST ANY EASEMENTS OR ENCUMBRANCES ON THE DEDICATED STREETS AND EASEMENTS.

IN WITNESS WHEREOF I HAVE HEREUNTO SET THIS 22 DAY OF February, A.D., 2006

James C. Yates
JAMES C. YATES, MANAGER OF YATES BOLLINGER & YATES, L.L.C.

CORPORATE ACKNOWLEDGMENT
STATE OF UTAH
COUNTY OF SALT LAKE

ON THE 22ND DAY OF February, A.D., 2006, PERSONALLY APPEARED BEFORE ME, THE UNDERSIGNED NOTARY PUBLIC, IN AND FOR SAID COUNTY OF SALT LAKE, IN SAID STATE OF UTAH, JAMES C. YATES, WHO BEING BY ME DULY SWORN OR AFFIRMED DID AFFIRM THAT HE IS THE MANAGER OF YATES BOLLINGER & YATES, L.L.C., AND THAT THE WITHIN OWNER'S DEDICATIONS WERE SIGNED IN BEHALF OF SAID YATES BOLLINGER & YATES, L.L.C., AND THE SAID DEDICATIONS WERE SIGNED FREELY AND VOLUNTARILY FOR THE PURPOSES STATED THEREIN.

MY COMMISSION EXPIRES 9-01-06

CORPORATE ACKNOWLEDGMENT
STATE OF UTAH
COUNTY OF SALT LAKE

ON THE 22ND DAY OF February, A.D., 2006, PERSONALLY APPEARED BEFORE ME, THE UNDERSIGNED NOTARY PUBLIC, IN AND FOR SAID COUNTY OF SALT LAKE, IN SAID STATE OF UTAH, JAMES C. YATES, WHO BEING BY ME DULY SWORN OR AFFIRMED DID AFFIRM THAT HE IS THE MANAGER OF YATES BOLLINGER & YATES, L.L.C., AND THAT THE WITHIN OWNER'S DEDICATIONS WERE SIGNED IN BEHALF OF SAID YATES BOLLINGER & YATES, L.L.C., AND THE SAID DEDICATIONS WERE SIGNED FREELY AND VOLUNTARILY FOR THE PURPOSES STATED THEREIN.

MY COMMISSION EXPIRES

RIVERBEND INDUSTRIAL PARK
LOCATED IN THE WEST HALF OF SECTION 10, TOWNSHIP 1 SOUTH, RANGE 1 WEST, SALT LAKE BASE AND MERIDIAN.
PREPARED BY:

WILDING ENGINEERING, INC.
1474 SOUTH 1000 WEST, SUITE 400, WEST VALLEY CITY, UTAH 84115
PH: 765-2111 FAX: 765-2112

STATE OF UTAH, COUNTY OF SALT LAKE, RECORDED AND FILED AT THE REQUEST OF **FOUNDERS TITLE**
DATE 4-13-06 TIME 12:59PM, BOOK 2006P, PAGE 1214
RECORDED # 9751286
\$81.00
DEPUTY: SALT LAKE COUNTY RECORDER

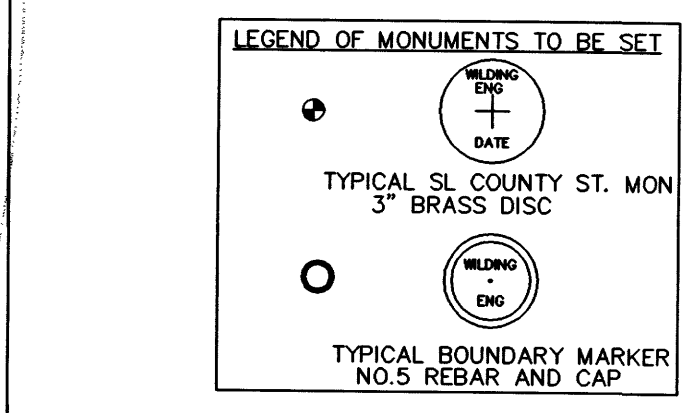
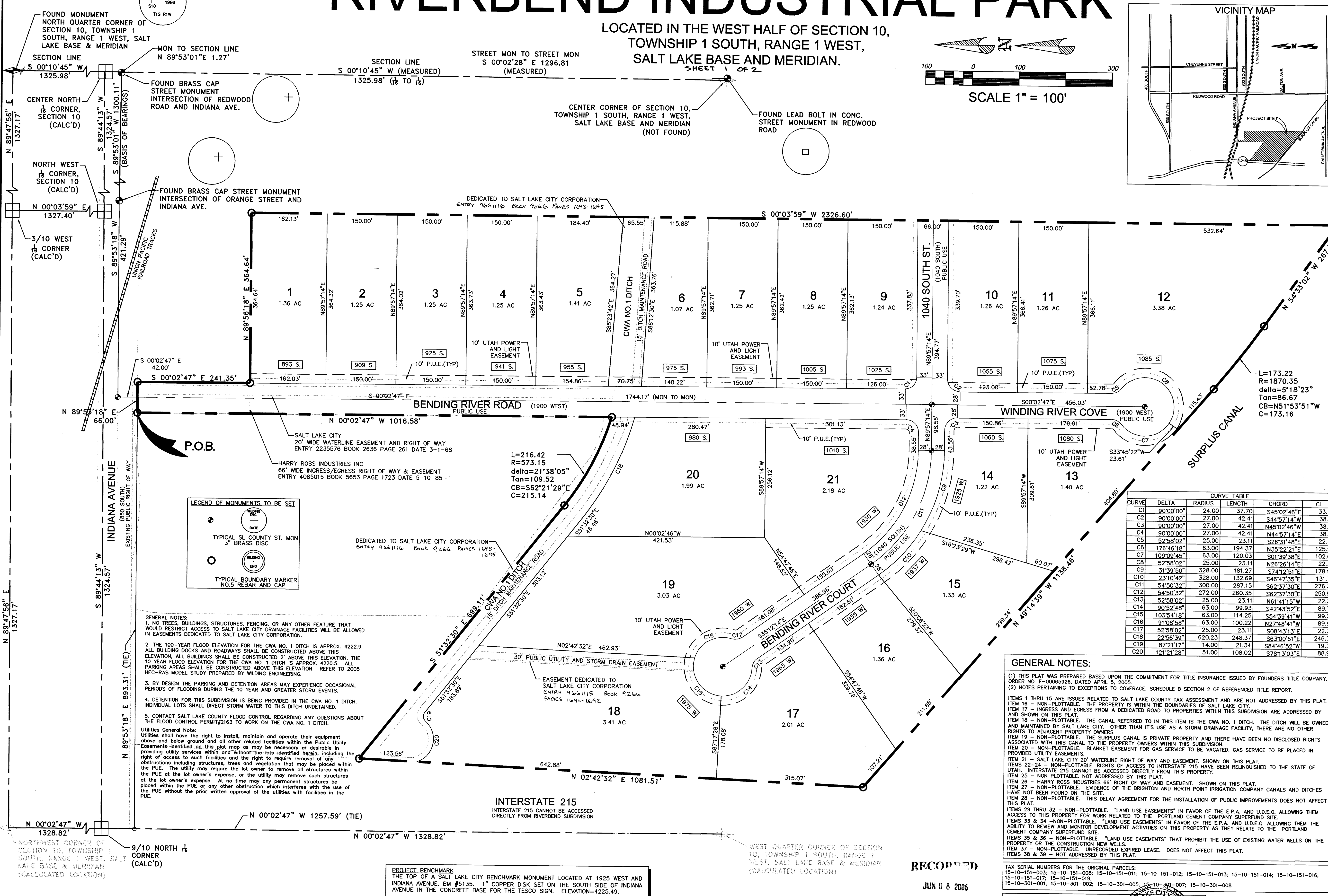

GENERAL NOTES:
1. NO TREES, BUILDINGS, STRUCTURES, FENCING, OR ANY OTHER FEATURE THAT WOULD RESTRICT ACCESS TO SALT LAKE CITY DRAINAGE FACILITIES WILL BE ALLOWED IN EASEMENTS DEDICATED TO SALT LAKE CITY CORPORATION.
2. THE 100-YEAR FLOOD ELEVATION FOR THE CWA NO. 1 DITCH IS APPROX. 4222.9. ALL BUILDING DOCKS AND ROADWAYS SHALL BE CONSTRUCTED ABOVE THIS ELEVATION. ALL BUILDINGS SHALL BE CONSTRUCTED ABOVE THIS ELEVATION. THE 10 YEAR FLOOD ELEVATION FOR THE CWA NO. 1 DITCH IS APPROX. 4220.5. ALL PARKING AREAS SHALL BE CONSTRUCTED ABOVE THIS ELEVATION. REFER TO 2005 HEC-RAS MODEL STUDY PREPARED BY WILDING ENGINEERING.
3. BY DESIGN THE PARKING AND DETENTION AREAS MAY EXPERIENCE OCCASIONAL PERIODS OF FLOODING DURING THE 10 YEAR AND GREATER STORM EVENTS.
4. DETENTION FOR THIS SUBDIVISION IS BEING PROVIDED IN THE CWA NO. 1 DITCH. INDIVIDUAL LOTS SHALL DIRECT STORM WATER TO THIS DITCH UNDETAINED.
5. CONTACT SALT LAKE COUNTY FLOOD CONTROL REGARDING ANY QUESTIONS ABOUT THE FLOOD CONTROL PERMIT#2163 TO WORK ON THE CWA NO. 1 DITCH.

Utilities General Note:
Utilities shall have the right to install, maintain and operate their equipment above and below ground and all other related facilities within the Public Utility Easements identified on this plat map as may be necessary or desirable in providing utility services within and without the lots identified herein, including the right of access to such facilities and the right to require removal of any obstructions including structures, trees and vegetation that may be placed within the P.U.E. The utility may require the lot owner to remove all structures within the P.U.E. at the lot owner's expense, or the utility may remove such structures at the lot owner's expense. At no time may any permanent structures be placed within the P.U.E. or any other obstruction which interferes with the use of the P.U.E. without the prior written approval of the utilities with facilities in the P.U.E.

PROJECT BENCHMARK
THE TOP OF A SALT LAKE CITY BENCHMARK MONUMENT LOCATED AT 1925 WEST AND INDIANA AVENUE, BM #5135. 1" COPPER DISK SET ON THE SOUTH SIDE OF INDIANA AVENUE IN THE CONCRETE BASE FOR THE TESCO SIGN. ELEVATION=4225.49.

SALT LAKE VALLEY HEALTH DEPT. NUMBER _____ ACCOUNT _____ SHEET _____ OF _____ SHEETS APPROVED THIS 15 TH DAY OF MARCH A.D., 2006 DIRECTOR, S.L. VALLEY HEALTH DEPT.	CITY PLANNING DIRECTOR APPROVED THIS 13 TH DAY OF April A.D., 2006 BY THE SALT LAKE CITY PLANNING COMMISSION. ACTED R.O. 4/13/06 SALT LAKE CITY PLANNING DIRECTOR	CITY ENGINEERING DIVISION I HEREBY CERTIFY THAT I HAVE HAD THIS PLAT EXAMINED BY THIS OFFICE AND IT IS CORRECT IN ACCORDANCE WITH THE INFORMATION ON FILE. CITY ENGINEER DATE 3-29-06 CITY SURVEYOR DATE 3-22-2006	CITY PUBLIC UTILITIES DEPT. APPROVED AS TO SANITARY SEWER, STORM DRAINAGE, AND WATER DETAILS THIS 15 DAY OF March 2006. SALT LAKE CITY PUBLIC UTILITIES DIRECTOR	CITY ATTORNEY APPROVED AS TO FORM THIS 8 TH DAY OF June A.D., 2006 SALT LAKE CITY ATTORNEY	CITY APPROVAL PRESENTED TO SALT LAKE CITY THIS 8 TH DAY OF June A.D., 2006, AND IT IS HEREBY APPROVED. SALT LAKE CITY MAYOR SALT LAKE CITY RECORDER DEPUTY: SALT LAKE COUNTY RECORDER	SALT LAKE COUNTY RECORDER STATE OF UTAH, COUNTY OF SALT LAKE, RECORDED AND FILED AT THE REQUEST OF FOUNDERS TITLE DATE 4-13-06 TIME 12:59PM, BOOK 2006P, PAGE 1214 RECORDED # 9751286 \$81.00 DEPUTY: SALT LAKE COUNTY RECORDER
---	--	--	---	--	---	--

151-003,008,011 THEU-014,301-001,002,005 & 007

15-10-11-831
#210

RIVERBEND INDUSTRIAL PARK

LOCATED IN THE WEST HALF OF SECTION 10,
TOWNSHIP 1 SOUTH, RANGE 1 WEST,
SALT LAKE BASE AND MERIDIAN.
SHEET 2 OF 2

NOTICE TO PURCHASER:

THIS PLAT WAS PREPARED BASED UPON THE COMMITMENT FOR TITLE INSURANCE ISSUED BY FOUNDERS TITLE COMPANY, ORDER NO. F-00065926, DATED APRIL 5, 2005. THE FOLLOWING ARE NOTES PERTAINING TO EXCEPTIONS TO COVERAGE, SCHEDULE B SECTION 2 OF REFERENCED TITLE REPORT.

ITEMS 1 THRU 15 ARE ISSUES RELATED TO SALT LAKE COUNTY TAX ASSESSMENT AND ARE NOT ADDRESSED BY THIS PLAT.

16. Said property is included within the boundaries of Salt Lake City, and is subject to the charges and assessments thereof.

17. Rights of ingress and/or egress from a dedicated street or highway are not disclosed of record, and such rights will be excluded from the coverage of our Policy. (Affects all parcels except "Road" parcel)

18. Rights associated with the Canal along the North line of "South/Rear" parcel and the South line of Parcel "N-C".

19. Rights associated with the Surplus Canal along the South line of "South/Rear" parcels.

20. EASEMENT AND CONDITIONS CONTAINED THEREIN:

Grantor: MARY O. ADAMS
Grantee: WASATCH GAS
Location: (Exact location not disclosed)
Purpose: Gas pipe lines, and incidental purposes
Dated: March 1, 1929
Recorded: March 22, 1929
Entry No.: 628763
Book/Page: 56/229

21. EASEMENT AND CONDITIONS CONTAINED THEREIN:

Grantor: COMMERCIAL SECURITY BANK, TRUSTEE
Grantee: SALT LAKE CITY
Location: Beginning at a point on the South line of Indiana Avenue, said point being North 0°03'08" West 1,235.90 feet and North 89°55'56" East 953.30 feet from the West quarter corner of Section 10, Township 1 South, Range 1 West, Salt Lake Base and Meridian, thence South 89°55'56" West along said South line 20.0 feet; thence South 0°03'08" East 995.0 feet, more or less, to the North bank of a canal; thence Southeasterly along said North bank 20.0 feet, more or less, to a point South 0°03'08" East from the point of beginning; thence North 0°03'08" West 1,000.00 feet, more or less, to point of beginning.
Purpose: A perpetual 20 foot right of way and easement for the construction, maintenance, replacement and repair of an 8 inch water main, water service lines and water meters (Watermain Extension No. 3446), and incidental purposes
Dated: February 19, 1968
Recorded: March 1, 1968
Entry No.: 2235576
Book/Page: 2636/261

22. Rights of access to I-215 have been relinquished to the State of Utah by instrument recorded August 19, 1971, as Entry No. 2404338, in Book 2989, at page 623, of Official Records.

23. Rights of access to I-215 have been relinquished to the State of Utah by instrument recorded October 5, 1971, as Entry No. 2413413, in Book 3003, at page 801, of Official Records.

24. Rights of access to I-215 have been relinquished to the State of Utah by instrument recorded March 7, 1972, as Entry No. 2441249, in Book 3048, at page 440, of Official Records.

25. The effects of Salt Lake City Ordinance No. 72 of 1983 for widening and relocation of Indiana Avenue and 900 South, recorded November 15, 1983, as Entry No. 3869405 in Book 5507, at Page 977, of Official Records.

26. EASEMENT AND CONDITIONS CONTAINED THEREIN:

Grantor: L. CLAIR WILLIAMSEN AND LARRY D. WILLIAMSEN
Grantee: HARRY ROSS INDUSTRIES, INC.
Location: A right of way and easement for ingress and egress, over and across the following described property: Beginning at a point on the South line of Indiana Avenue, said point being North 0°03'08" West 1268.68 feet and North 89°55'56" East 893.30 feet from the West quarter corner of Section 10, Township 1 South, Range 1 West, Salt Lake Base and Meridian; thence North 89°55'56" East 66.00 feet; thence South 0°03'08" East 251.34 feet; thence South 89°55'56" West 66.00 feet; thence North 0°03'08" West 251.34 feet to the point of beginning.
Purpose: Ingress and egress, over and across above property, and incidental purposes
Dated: May 10, 1985
Recorded: May 10, 1985
Entry No.: 4085015
Book/Page: 5653/1723

27. Any easements and/or rights of way for the water distribution system and appurtenances of the Brighton and North Point Irrigation Company and/or the State of Utah Board of Water Resources, as the same may be found to intersect the herein described property, as disclosed by mesne instruments of record, including that certain Easement To Use Distribution System recorded September 26, 1988, as Entry No. 4680089, in Book 6067, at page 404, of Official Records.

28. Standard Form Agreement for Waiver of Installation of Public Way Improvement dated March 10, 1992 and recorded March 12, 1992, as Entry No. 5214086 in Book 6423, at Page 1539, of Official Records.

29. LAND USE EASEMENT

Grantor: WILLIAMSEN INVESTMENT COMPANY
Grantee: UNITED STATES AND THE STATE OF UTAH
Location: See document
Purpose: See document
Recorded: March 18, 1999
Entry No.: 7292784
Book/Page: 8259/5198

30. LAND USE EASEMENT

Grantor: L. CLAIR WILLIAMSEN; LARRY D. WILLIAMSEN; SHIRLEY WILLIAMSEN AND SOUTHWEST INVESTMENT COMPANY
Grantee: UNITED STATES AND THE STATE OF UTAH
Location: See document for particulars
Purpose: See document for particulars
Recorded: March 18, 1999
Entry No.: 7292785
Book/Page: 8259/5204

31. LAND USE EASEMENT

Grantor: WILLIAMSEN INVESTMENT COMPANY
Grantee: UNITED STATES AND THE STATE OF UTAH
Location: See document for particulars
Purpose: See document for particulars
Recorded: March 18, 1999
Entry No.: 7292786
Book/Page: 8259/5212

32. LAND USE EASEMENT

Grantor: L. CLAIR WILLIAMSEN; LARRY D. WILLIAMSEN; SHIRLEY WILLIAMSEN AND SOUTHWEST INVESTMENT COMPANY
Grantee: UNITED STATES AND THE STATE OF UTAH
Location: See document for particulars
Purpose: See document for particulars
Recorded: March 18, 1999
Entry No.: 7292787
Book/Page: 8259/5217

33. LAND USE EASEMENT

Grantor: WILLIAMSEN INVESTMENT COMPANY
Grantee: UNITED STATES AND THE STATE OF UTAH
Location: See document for particulars
Purpose: See document for particulars
Recorded: March 18, 1999
Entry No.: 7292788
Book/Page: 8259/5224

34. LAND USE EASEMENT

Grantor: L. CLAIR WILLIAMSEN; LARRY D. WILLIAMSEN; SHIRLEY WILLIAMSEN AND SOUTHWEST INVESTMENT COMPANY
Grantee: UNITED STATES AND THE STATE OF UTAH
Location: See document for particulars
Purpose: See document for particulars
Recorded: March 18, 1999
Entry No.: 7292789
Book/Page: 8259/5233

35. LAND USE EASEMENT

Grantor: WILLIAMSEN INVESTMENT COMPANY
Grantee: UNITED STATES AND THE STATE OF UTAH
Location: See document for particulars
Purpose: See document for particulars
Recorded: March 18, 1999
Entry No.: 7292790
Book/Page: 8259/5244

36. LAND USE EASEMENT

Grantor: L. CLAIR WILLIAMSEN; LARRY D. WILLIAMSEN; SHIRLEY WILLIAMSEN AND SOUTHWEST INVESTMENT COMPANY
Grantee: UNITED STATES AND THE STATE OF UTAH
Location: See document for particulars
Purpose: See document for particulars
Recorded: March 18, 1999
Entry No.: 7292791
Book/Page: 8259/5251

37. "Intentionally Deleted"

38. "Intentionally Deleted"

39. "Intentionally Deleted"

40. DEED OF TRUST

Trustor: Yates, Bolinder, & Yates, LLC
Trustee: Bank of American Fork
Beneficiary: Bank of American Fork
Amount: \$3,256,159.00, plus interest
Dated: February 8, 2006
Recorded: February 10, 2006
Entry No.: 9635005
Book/Page: 9254/2371

41. EASEMENT AND CONDITIONS CONTAINED THEREIN:

Grantor: Yates, Bolinder, & Yates, LLC
Grantee: Salt Lake City Corporation, a municipal corporation
Purpose: drainage facilities, and incidental purposes
Dated: March 13, 2006
Recorded: March 14, 2006
Entry No.: 9661115
Book/Page: 9266/1690

42. EASEMENT AND CONDITIONS CONTAINED THEREIN:

Grantor: Yates, Bolinder, & Yates, LLC
Grantee: Salt Lake City Corporation, a municipal corporation
Purpose: CWA Drain No. 1, and incidental purposes
Dated: March 13, 2006
Recorded: March 14, 2006
Entry No.: 9661116
Book/Page: 9266/1693

CONSENT TO DEDICATE:

THE UNDERSIGNED TRUSTEE OF AN EQUITABLE OR LEGAL INTEREST IN THE DESCRIBED RIVERBEND INDUSTRIAL PARK DOES HEREBY CONSENT TO THE DEDICATION BY THE OWNER THEREOF ALL STREETS AND EASEMENTS, AS SHOWN HEREON, FOR THE PERPETUAL USE OF THE PUBLIC. THE UNDERSIGNED DOES HEREBY DEDICATED ITS INTEREST IN AND TO THE LAND INCLUDED WITHIN SUCH PUBLIC STREETS AND EASEMENTS TO SALT LAKE CITY CORPORATION FOREVER.

TRUSTEE SIGNATURE: Stephen S. Swenson S.E.P.
COMPANY: BANK OF AMERICAN FORK
LEHI BRANCH
712 EAST MAIN
LEHI, UTAH 84043

ACKNOWLEDGEMENT

STATE OF UTAH
COUNTY OF ~~SALT LAKE~~ Utah
ON THIS 7th DAY OF April A.D.; 2006, PERSONALLY APPEARED BEFORE ME, THE UNDERSIGNED NOTARY PUBLIC, IN AND FOR SAID COUNTY OF SALT LAKE, IN SAID STATE OF UTAH, Stephen S. Swenson WHO BEING BY ME DULY SWORN OR AFFIRMED DID AFFIRM THAT THEY ARE THE Senior Vice President OF Bank of American Fork AND THAT THE WITHIN INSTRUMENT WAS SIGNED IN BEHALF OF SAID CORPORATION AND SAID PERSON ACKNOWLEDGED TO ME THAT SAID CORPORATION EXECUTED THE SAME.

MY COMMISSION EXPIRES
12-19-2006

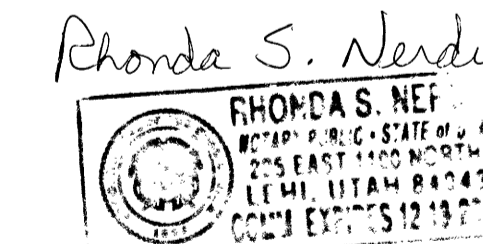

RIVERBEND INDUSTRIAL PARK
LOCATED IN THE WEST HALF OF SECTION 10, TOWNSHIP 1 SOUTH, RANGE 1 WEST, SALT LAKE BASE AND MERIDIAN.
SHEET 2 OF 2

PREPARED BY:



SALT LAKE COUNTY RECORDER

STATE OF UTAH, COUNTY OF SALT LAKE, RECORDED AND FILED AT THE
REQUEST OF FOUNDERS TITLE
DATE 4-13-06 TIME 12:58 PM BOOK 2006P PAGE 114
RECORDED # 9751285
\$ 81.00 FEE \$
David Dore
DEPUTY: SALT LAKE COUNTY RECORDER

NUMBER _____
ACCOUNT _____
SHEET _____
OF _____ SHEETS

NUMBER _____
ACCOUNT _____
SHEET _____
OF _____ SHEETS