

57  
12

WHEN RECORDED, RETURN TO:  
Town of Eagle Mountain  
Janet B. Valentine  
1680 E. Heritage Drive  
Eagle Mountain, Utah 84043

ENT 62083:2000 Pg 1 of 12  
RANDALL A. COVINGTON  
UTAH COUNTY RECORDER  
2000 Aug 09 10:53 AM FEE 57.00 BY NL  
RECORDED FOR TOWN OF EAGLE MOUNTAIN

**SECOND SUPPLEMENT TO THE  
DECLARATION OF COVENANTS, CONDITIONS AND RESTRICTIONS  
FOR  
SADDLEBACK AT SMITH RANCH SUBDIVISION**

This SECOND SUPPLEMENT TO THE DECLARATION OF COVENANTS, CONDITIONS AND RESTRICTIONS FOR SADDLEBACK AT SMITH RANCH SUBDIVISION is made and executed by SADDLEBACK PROPERTY, L.C., a Utah limited liability company, of 758 South 400 East, Suite 203, Orem, Utah 84058 (hereinafter referred to as "Declarant").

**RECITALS**

Whereas, the SADDLEBACK AT SMITH RANCH SUBDIVISION is subject to unrecorded RANCHES AT EAGLE MOUNTAIN COMMUNITY DECLARATION (the "COMMUNITY DECLARATION").

Whereas, the DECLARATION OF COVENANTS, CONDITIONS AND RESTRICTIONS FOR SADDLEBACK AT SMITH RANCH SUBDIVISION was recorded in the office of the County Recorder of Utah County, Utah on the 10th day of December, 1999, as Entry No. 127983 in Book 5296 at Page 163 of the Official Records of the County Recorder of Utah County, Utah (the "Declaration").

Whereas, the related Map(s) for Plat A of the Project has also been recorded in the office of the County Recorder of Utah County, Utah.

Whereas, the First Supplemental Declaration has been or will be recorded for Plat B (the "First Supplement").

Whereas, the related Map(s) for Plat B of the Project has also been or will be recorded in the office of the County Recorder of Utah County, Utah.

Whereas, under Article III, Section 28 of the Declaration, Declarant reserved an option until the ten (10) years from the date following the first conveyance of a Lot in Plat A to a Lot purchaser to expand the Subdivision.

Whereas, Declarant is the fee simple owner of record of that certain real property located in Utah County, Utah and described with particularity on Exhibit "A-3" attached hereto and

incorporated herein by this reference (the "Plat C Property").

Whereas, under the provisions of the Declaration, Declarant expressly reserved the absolute right to add to the Project additional land at any time and in any order, without limitation.

Whereas, Declarant desires to expand the Project by creating on the Plat C Property a residential development.

Whereas, Declarant now intends that the Plat C Property shall become subject to the Declaration.

NOW, THEREFORE, for the reasons recited above, and for the benefit of the Project and the Unit Owners thereof, Declarant hereby executes this SECOND SUPPLEMENT TO THE DECLARATION OF COVENANTS, CONDITIONS AND RESTRICTIONS FOR SADDLEBACK AT SMITH RANCH SUBDIVISION.

1. Supplement to Definitions. Article I of the Declaration, entitled "Definitions," is hereby modified to include the following supplemental definitions:

A. Second Supplemental Declaration shall mean and refer to this SECOND SUPPLEMENT TO THE DECLARATION OF COVENANTS, CONDITIONS AND RESTRICTIONS FOR SADDLEBACK AT SMITH RANCH SUBDIVISION.

B. Second Supplemental Plat C Map shall mean and refer to the Supplemental Plat Map of Plat C of the Project, prepared and certified to by David V. Thomas, a duly registered Utah Land Surveyor holding Certificate No.163947, and filed for record in the Office of the County Recorder of Utah County, Utah concurrently with the filing of this Second Supplemental Declaration.

Except as otherwise herein provided, the definition of terms contained in the Declaration are incorporated herein by this reference.

2. Legal Description. The real property described in Exhibit A-3 is hereby submitted to the provisions of the Declaration and said land shall be held, transferred, sold, conveyed and occupied subject to the provisions of the Declaration, as supplemented and amended.

3. Annexation. Declarant hereby declares that the Plat C Property shall be annexed to and become subject to the Declaration, which upon recordation of this Second Supplemental Declaration shall constitute and effectuate the expansion of the Project, making the real property described in Exhibit A-3 subject to the functions, powers, rights, duties and jurisdiction of the Association.

4. Total Number of Units Revised. As shown on the Plat C Map, 23 additional Lots will be added to the Subdivision as Plat C. Upon the recordation of the Plat C Map and this Second Supplemental Declaration, the total number of Lots in the Subdivision will be 78.

5. Percentage Interest Revised. With the additional Lots, the percentage interest of the Lot Owners in the subassociation will change. Revised Exhibit "B" to the Declaration is deleted in its entirety and "Second Revised Exhibit 'B,'" attached hereto and incorporated herein by this reference, is substituted in lieu thereof.

6. Effective Date. The effective date of this Second Supplemental Declaration and the Plat C Map shall be the date on which said instruments are filed for record in the Office of the County Recorder of Utah County, Utah.

IN WITNESS WHEREOF, Declarant has executed this instrument the 26 day of April, 2000.

DECLARANT:  
SADDLEBACK PROPERTY, L.C.  
a Utah limited liability company

By: [Signature]  
Title: Wayne Corbridge, Manager

STATE OF UTAH            )  
  )ss.  
COUNTY OF UTAH        )

On the 26 day of April, 2000, personally appeared before me Wayne Corbridge, who by me being duly sworn, did say that he is the Manager of SADDLEBACK PROPERTY, L.C., a Utah limited liability company, and that the within and foregoing instrument was signed in behalf of said company pursuant to the resolution of its Members or its Articles of Organization, and said Wayne Corbridge duly acknowledged to me that said company executed the same.

[Signature]  
NOTARY PUBLIC  
Residing At: Lindon, UT

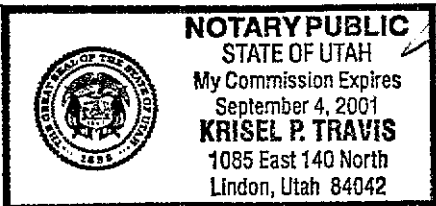

**EXHIBIT "A-3"**  
**LEGAL DESCRIPTION**

## SURVEYOR'S CERTIFICATE

I, DAVID V. THOMAS, DO HEREBY CERTIFY THAT I AM A REGISTERED LAND SURVEYOR, AND THAT I HOLD CERTIFICATE NO. 163947 AS PRESCRIBED UNDER THE LAWS OF THE STATE OF UTAH. I FURTHER CERTIFY BY AUTHORITY OF THE OWNERS, I HAVE MADE A SURVEY OF THE TRACT OF LAND SHOWN ON THIS PLAT AND DESCRIBED BELOW, AND HAVE SUBDIVIDED SAID TRACT OF LAND INTO LOTS, BLOCKS, STREETS, PUBLIC OPEN SPACE, AND EASEMENTS AND THE SAME HAS BEEN CORRECTLY SURVEYED AND STAKED ON THE GROUND AS SHOWN ON THIS PLAT AND THAT THIS PLAT IS TRUE AND CORRECT.

DATE

SURVEYOR

(SEE SEAL BELOW)

## BOUNDARY DESCRIPTION

BEGINNING AT A POINT LOCATED SOUTH 1533.25 FEET AND EAST 437.04 FEET FROM THE NORTH QUARTER CORNER OF SECTION 29, TOWNSHIP 5 SOUTH, RANGE 1 WEST, SALT LAKE BASE & MERIDIAN;

RUNNING THENCE EASTERLY ALONG THE ARC OF A 250.00 FOOT RADIUS CURVE TO THE RIGHT 106.76 FEET (SAID CURVE HAS A CENTRAL ANGLE OF 24°28'00" AND A CHORD BEARING N 87°01'43" E 105.95 FEET); THENCE N 09°15'43" E 29.67 FEET; THENCE N 35°53'37" E 95.00 FEET; THENCE S 54°06'23" E 400.00 FEET; THENCE N 35°53'37" E 20.00 FEET; THENCE S 54°06'23" E 90.00 FEET; THENCE N 35°53'37" E 315.00 FEET; THENCE S 54°06'23" E 105.00 FEET TO THE POINT OF CURVATURE OF A 15.00 FOOT RADIUS CURVE TO THE RIGHT; THENCE SOUTHERLY ALONG THE ARC OF SAID CURVE 23.56 FEET (SAID CURVE HAS A CENTRAL ANGLE OF 90°00'00" AND A CHORD BEARING S 09°06'23" E 21.21 FEET); THENCE S 54°06'23" E 60.00 FEET; THENCE S 35°53'37" W 450.00 FEET; THENCE N 54°06'23" W 180.00 FEET; THENCE S 86°57'58" W 183.02 FEET; THENCE N 54°06'23" W 216.99 FEET; THENCE N 81°58'19" W 75.97 FEET; THENCE N 21°34'46" W 101.96 FEET; THENCE N 15°12'18" W 60.00 FEET TO THE POINT OF BEGINNING.

CONTAINING 4.65 ACRES.

## EAGLE MOUNTAIN DEVELOPER PLAT DEDICATION

WE, THE UNDERSIGNED OWNERS OF ALL THE REAL PROPERTY DEPICTED ON THIS PLAT AND DESCRIBED IN THE SURVEYORS CERTIFICATE ON THIS PLAT, HAVE CAUSED THE LAND DESCRIBED ON THE PLAT TO BE DIVIDED INTO LOTS, STREETS, OPEN SPACE, EASEMENTS AND OTHER PUBLIC USES AS DESIGNATED ON THIS PLAT AND NOW DO HEREBY DEDICATE UNDER THE PROVISIONS OF 10-9-807 UTAH CODE, WITHOUT CONDITION, RESTRICTION OR RESERVATION TO THE TOWN OF EAGLE MOUNTAIN, UTAH, ALL STREETS, WATER, SEWER AND OTHER UTILITY IMPROVEMENTS, OPEN SPACES SHOWN AS PUBLIC OPEN SPACES, PARKS, EASEMENTS AND ALL OTHER PLACES OF PUBLIC IMPROVEMENTS REQUIRED BY THE DEVELOPMENT AGREEMENT BETWEEN THE UNDERSIGNED AND THE TOWN OF EAGLE MOUNTAIN FOR THE BENEFIT OF THE TOWN AND THE INHABITANTS THEREOF.

IN WITNESS HEREOF WE HAVE HEREUNTO SET OUR HANDS THIS \_\_\_\_\_

The additional land added to the Project and referred to in the foregoing Declaration as Plat C is located in Utah County, Utah, and is described more particularly as follows:

### Property Description

The land referred to is located in Utah County, State of Utah, and is described as follows:

Beginning at a point located South 1533.25 feet and East 437.04 feet from the North quarter corner of Section 29, Township 5 South, Range 1 West, Salt Lake Base and Meridian; running thence Easterly along the arc of a 250.00 foot radius curve to the right 106.76 feet (said curve has a central angle of 24° 28' 00" and a chord bearing North 87° 01' 43" East 105.95 feet); thence North 09° 15' 43" East 29.67 feet; thence North 35° 53' 37" East 95.00 feet; thence South 54° 06' 23" East 400.00 feet; thence North 35° 53' 37" East 20.00 feet; thence South 54° 06' 23" East 90.00 feet; thence North 35° 53' 37" East 315.00 feet; thence South 54° 06' 23" East 105.00 feet to the point of a curvature of a 15.00 foot radius curve to the right; thence Southerly along the arc of said curve 23.56 feet ( said curve has a central angle of 90° 00' 00" and a chord bearing South 09° 06' 23" East 21.21 feet); thence South 54° 06' 23" East 60.00 feet; thence South 35° 53' 37" West 450.00 feet; thence North 54° 06' 23" West 180.00 feet; thence South 86° 57' 58" West 183.02 feet; thence North 54° 06' 23" West 216.99 feet; thence North 81° 58' 19" West 75.97 feet; thence North 21° 34' 46" West 101.96 feet; thence North 15° 12' 18" West 60.00 feet to the point of beginning. (TO BE KNOWN AS PLAT "C" SADDLEBACK SUBDIVISION.)

**SECOND REVISED EXHIBIT "B"**  
**PERCENTAGES OF OWNERSHIP INTEREST**

<u>Plat</u>	<u>Lot No.</u>	<u>Fractional Interest</u>	<u>Percentage of Ownership Interest</u>
A	1	1/78	1.28%
A	2	1/78	1.28%
A	3	1/78	1.28%
A	4	1/78	1.28%
A	5	1/78	1.28%
A	6	1/78	1.28%
A	7	1/78	1.28%
A	8	1/78	1.28%
A	9	1/78	1.28%
A	10	1/78	1.28%
A	11	1/78	1.28%
A	12	1/78	1.28%
A	13	1/78	1.28%
A	14	1/78	1.28%
A	15	1/78	1.28%
A	16	1/78	1.28%
A	17	1/78	1.28%
A	18	1/78	1.28%
A	19	1/78	1.28%
A	20	1/78	1.28%
A	21	1/78	1.28%
A	22	1/78	1.28%
A	23	1/78	1.28%
A	24	1/78	1.28%
A	25	1/78	1.28%
A	26	1/78	1.28%
A	27	1/78	1.28%
A	28	1/78	1.28%
A	29	1/78	1.28%
A	30	1/78	1.28%
A	31	1/78	1.28%
A	32	1/78	1.28%

<u>Plat</u>	<u>Lot No.</u>	<u>Fractional Interest</u>	<u>Percentage of Ownership Interest</u>
B	33	1/78	1.28%
B	34	1/78	1.28%
B	35	1/78	1.28%
B	36	1/78	1.28%
B	37	1/78	1.28%
B	38	1/78	1.28%
B	39	1/78	1.28%
B	40	1/78	1.28%
B	41	1/78	1.28%
B	42	1/78	1.28%
B	43	1/78	1.28%
B	44	1/78	1.28%
B	45	1/78	1.28%
B	46	1/78	1.28%
B	47	1/78	1.28%
B	48	1/78	1.28%
B	49	1/78	1.28%
B	50	1/78	1.28%
B	51	1/78	1.28%
B	52	1/78	1.28%
B	53	1/78	1.28%
B	54	1/78	1.28%
B	55	1/78	1.28%

<u>Plat</u>	<u>Lot No.</u>	<u>Fractional Interest</u>	<u>Percentage of Ownership Interest</u>
C	56	1/78	1.28%
C	57	1/78	1.28%
C	58	1/78	1.28%
C	59	1/78	1.28%
C	60	1/78	1.28%
C	61	1/78	1.28%
C	62	1/78	1.28%
C	63	1/78	1.28%
C	64	1/78	1.28%
C	65	1/78	1.28%
C	66	1/78	1.28%
C	67	1/78	1.28%
C	68	1/78	1.28%
C	69	1/78	1.28%
C	70	1/78	1.28%
C	71	1/78	1.28%
C	72	1/78	1.28%
C	73	1/78	1.28%
C	74	1/78	1.28%
C	75	1/78	1.28%
C	76	1/78	1.28%
C	77	1/78	1.28%
C	78	1/78	1.28%
<hr/>			
TOTAL:			100.00%



# Exhibit B

- POST OFFICE APPROVED PAINTED MAIL BOX STEEL, 7" W. X 10" H. X 21" B., MEDIUM BROWN COLOR.

- 6" X 6" CEDAR POST, SET IN CONCRETE WITH COPE TOP.

- 3/8" X 3/8" REVEAL.

- (2) 2X6 CEDAR RAILS. ROUTER IN FLUSH WITH FACE OF POST, ANGLE CUT.

- 2" BLACK VINYL SELF-ADHESIVE LETTERS, HELY. MED.

- (4) 3/8" CARRIAGE BOLTS, BLACK FINISH, COUNTER SINK BOTH SIDES

- VERIFY MOUNTING HEIGHT WITH LOCAL POSTMASTER

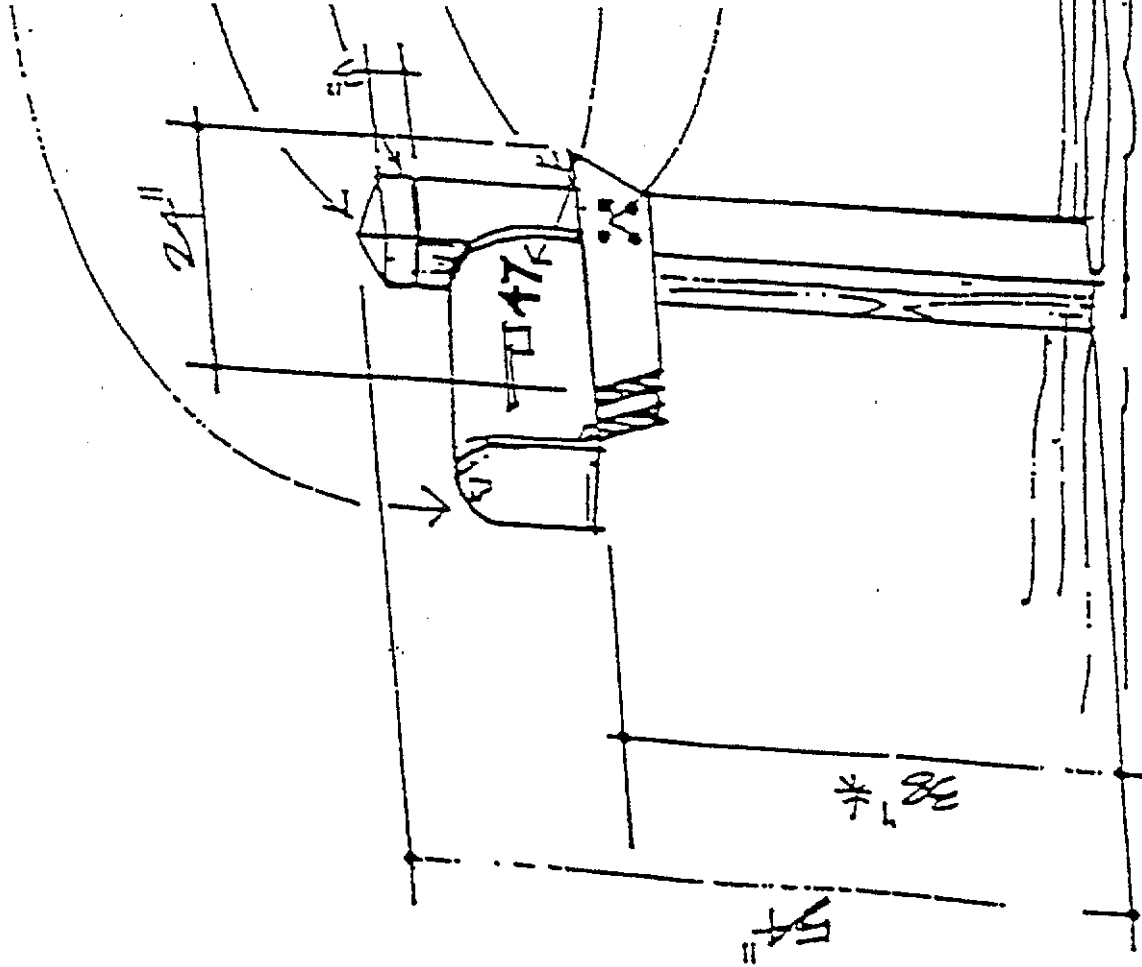

Not Drawn to Scale

## Mail Box Standard

# ***EXHIBIT 4***

## **SPECIAL CONDITIONS**

**Exhibit '4'**  
**SPECIAL CONDITIONS**  
**Ranches Master Plan Area**

**Disclosure and Acknowledgment Concerning Availability of Municipal Services**

The Developer understands that the Town of Eagle Mountain provides municipal services where and when available to its residents. Approval by the Town to record a subdivision plat or the issuance of a building permit by the Town is not a commitment by the Town to supply water, sewer, electric power, or telephone services at this date. The Town has insufficient capacity as of the date of this agreement, to provide water, electric power, and telephone service to the properties of the Developer's project described on Exhibit "1" and may not provide water, telephone and electric power services unless the Town has acquired sufficient facilities to do so. The Ranches, L.C. has assumed the obligation to build certain facilities, and if the required facilities are not constructed by The Ranches, L.C., the Town may not have sufficient capacity to supply water and power when a home is ready for occupancy. Contact The Ranches, L.C. for further information or the Town of Eagle Mountain Engineer for further information.

The Developer is required and hereby agrees to print the statement set forth below in all documents offering any part of the project for sale and to require in all subsequent sale documents that each subsequent purchaser also require continuing disclosure and disclose to future purchasers the following statement in all sale documents offering the project or any part of the project for sale.

**NORTH AREA UTILITIES DISCLOSURE**

**The Town of Eagle Mountain is a rapidly growing community and because of the rapid growth, the Town needs more water, power and telephone utility facilities. The Town has entered into an agreement with The Ranches, L.C. to provide additional utilities which are required by utility capacity demands as The Ranches area grows. In the event that The Ranches is deficient in funding the growth of the utilities, the Town is not liable for utility deficits encountered by home buyers or builders and may not have capacity to supply certain utilities. To find out the status of utility capacity, contact the Town of Eagle Mountain Engineer.**

I have read the statement above concerning utilities in the Town of Eagle Mountain.

Date: \_\_\_\_\_

\_\_\_\_\_  
 Buyer

\_\_\_\_\_  
 Buyer

A copy of seller's sales literature and sales documents shall be available upon reasonable request of the Town to verify the Developer's and subsequent sellers compliance with this Special Condition.

Page 2

Exhibit '4'  
**SPECIAL CONDITIONS**

1. No building permits will be allowed until all new utilities are looped to the existing utility system.
  
2. No occupancy permits will be granted for lots in Saddleback Plats B and C; Three Crossings Plats A, B, and C; Porter's Crossing Plats A, B, and C; and O'Fallon's Bluff until a secondary road is accessible to each subdivision.