

WHEN RECORDED, RETURN TO:

Heber City
Attention: City Recorder
75 North Main Street
Heber City, Utah 84032
Tax Parcel Nos.: 00-0021-6813, 00-0007-8431, 00-0007-7797

(Space above for Recorder's use only.)

**THIRD AMENDMENT
TO
DEVELOPMENT AGREEMENT
FOR THE
HIGHLANDS MASTER PLANNED COMMUNITY**

THIS THIRD AMENDMENT TO DEVELOPMENT AGREEMENT FOR THE HIGHLANDS MASTER PLANNED COMMUNITY (this "**Amendment**") is entered into this ____ day of January, 2024, by and between HEBER CITY, a political subdivision of the State of Utah (the "**City**"), and CARDINAL FUNDING, LLC, a Utah limited liability company ("**Cardinal Funding**"). Each of Cardinal Funding and the City are hereinafter referred to individually as a "**Party**" and collectively as the "**Parties**"

RECITALS:

A. This Amendment amends that certain Development Agreement for the Highlands Master Planned Community (the "**Original Agreement**"), which Original Agreement is dated December 7, 2021 and was recorded in the official records of the Wasatch County Recorder on April 14, 2021 as Entry No. 518203 in Book 1405 at Page 1517-1607 (as such Original Agreement has been modified or amended prior to the date hereof and by this Amendment, the "**Agreement**"). Capitalized terms not otherwise defined in this Amendment shall have the meaning ascribed to them in the Original Agreement.

B. The Original Agreement was entered into by and among the City and Cardinal Funding with respect to that certain real property (the "**Property**") described therein and described on Exhibit A attached hereto, which Property is presently owned by Thackeray Family Holdings II, LLC, a Utah limited liability company ("**TFHII**") and Johansen Family Holdings II, LLC, a Utah limited liability company ("**JFHII**") and together with TFHII, the "**Landowners**"), which are executing this Amendment as owners of the Property.

C. The Original Agreement incorporated certain Design Guidelines, which Design Guidelines "are the approved guidelines for certain aspects of the design and construction of the development of the Property, including setbacks, building sizes, open space, height limitations, parking and signage, and, the design and construction standards for buildings, roadways and infrastructure, as set forth in and adopted as part of [the Original Agreement.]"

D. The Design Guidelines are applied in the context of the Zone, as the Zone is interpreted, clarified and/or modified by the City pursuant to this Agreement, and Cardinal Funding has sought certain interpretive guidance and clarification and certain amendments or other modifications from the City with respect to the Zone.

E. The Original Agreement was previously modified through an Administrative Amendment approved by Staff and recognized by the City Council on July 19, 2022 for the Highlands Conceptual Master Plan V6 (dated January 31, 2022) (the "**First Amendment**"). Staff approved the First Amendment on July 27, 2022. The First Amendment revised the general layout of the residential portion of the development, including a revision of the number of stacked flats, decreasing the total number of dwelling units and increasing the number of owner-occupied units. This Amendment entirely replaces and supersedes the First Amendment.

F. The Original Agreement was previously modified through an Administrative Amendment approved by Staff and recognized by the City Council on September 20, 2022 (the "**Second Amendment**"). Staff approved the Second Amendment on October 18, 2022. The Second Amendment modified the layout of the development to accommodate the City's Storm Water Master Plan. Such modifications included relocation of the clubhouse, the addition of several detention basins to be located throughout the development area and modifications to the Community Park, including the addition of a water feature planned to traverse through the Community Park and Town Center. Additionally, the commercial storage building was moved to the southern end of the development, and the size of the hotel was increased. The changes approved pursuant to the Second Amendment resulted in a decrease of 45 housing units and a decrease of ERU's by 0.74. This Amendment replaces and supersedes the Second Amendment, except for the Water Feature Amenity details, which are retained pursuant to the Third Amendment as shown in Exhibit O attached hereto.

G. The City's planning staff and Planning Commission have reviewed the proposed clarifications, modifications and amendments in one or more public hearings and provided a recommendation to the City Council based upon the unique and challenging topography of the Property but also seeking to maintain the overall intent of the required zoning design elements. On January 2, 2024, the City Council approved this Amendment as an Administrative Amendment pursuant to the requirements of the Original Agreement.

H. The upper road, Coyote View Drive, is a major reason for this Amendment, as the City and the adjoining Jordanelle Ridge Development desire to relocate Coyote View Drive to a location that differs from that shown in the Original Highlands Master Plan. This road relocation was done to facilitate a better design of the Arts District to the North of the Property.

I. At the request of the City, Cardinal Funding or its affiliates have exchanged real property (the "**Property Exchange**") along the eastern boundary of the Property with RE Investment Holdings, L.L.C. ("**REIH**").

J. The property owned by REIH prior to the Property Exchange was subject to that certain Development Agreement for the Upper Jordanelle Master Planned Community, recorded in the office of the Wasatch County Recorder on November 2, 2020 as Entry No. 487731 in Book 1321 at Page 1398 (as amended, supplemented or otherwise modified, the "**Upper Jordanelle Development Agreement**").

K. Cardinal Funding and the City desire to amend the Original Agreement so as to recognize the effect of the Property Exchange and to provide for the application of this Agreement to the property received by Cardinal Funding or its affiliates in the Property Exchange.

L. Pursuant to the requirements of Sections 17 and 18 of the Original Agreement, Cardinal Funding and the City are authorized and have the right to amend the Original Agreement and now desire to amend the Original Agreement as more fully set forth below.

AGREEMENT:

NOW, THEREFORE, in consideration of the foregoing and the mutual covenants made herein and in the Original Agreement, the receipt and sufficiency of which are hereby acknowledged, the parties to this Amendment agree as follows:

1. **Amendment of Section 1.2.69.** Section 1.2.69 of the Agreement is hereby amended and restated in its entirety as follows:

1.2.69 **Zone** means the City's North Village Overlay District Zone, as interpreted, clarified, amended or modified by the "NVOZ Specific Application Standards—Highlands Master Planned Community" attached to this Agreement as **Exhibit L**.

2. **Amendment of Section 3.1.** Section 3.1 of the Agreement is hereby amended such that the Base Density Entitlements (670 ERUs) are increased to 691 ERUs by reason of the property exchange and resulting additional property area described in Section 5 of this Amendment; provided, however, the twenty-one (21) additional ERUs shall not be used in the calculation of Bonus Density Entitlements under the Original Agreement and the Parties acknowledge and agree that the 691 ERUs set forth above do not include the 67 affordable housing units included in the Bonus Density Entitlements, which affordable housing units are unaffected by this Amendment for a total of 758 ERUs.

3. **References to "NVOZ" or "NVOZ Zone and Ordinance".** All references to the terms "NVOZ" and "NVOZ Zone and Ordinance" included in the Original Agreement are hereby changed to "Zone."

4. **Exhibits.** Exhibit D to the Original Agreement (i.e. the Master Plan) is hereby replaced with Exhibit D attached to this Amendment (i.e. the A&R Master Plan, dated October 19, 2023).

5. **Addition/Removal of Property.** In recognition of the Property Exchange and from and after the date of this Amendment, the Parties agree that: (a) the real property described on Exhibit M attached hereto shall no longer be subject to the Upper Jordanelle Development Agreement and shall be subject to and governed by the Agreement; and (b) the real property described on Exhibit N attached hereto shall no longer be subject to the Agreement and shall be subject to and governed by the Upper Jordanelle Development Agreement. Taking into account the foregoing adjustments, the Property subject to the Original Agreement, as amended, is the real property described on Exhibit P attached hereto.

6. **Conflicts.** In the event of any conflict between the terms and conditions set forth in this Amendment and those set forth in the Original Agreement, the terms and conditions of this Amendment shall control.

7. **Ratification.** Except as expressly set forth in this Amendment, the Agreement is ratified and confirmed as written.

[Signatures appear on the following pages]

IN WITNESS WHEREOF, this Amendment has been entered into by and among the City and Cardinal Funding with the consent and agreement of the Landowners as of the date and year first above written.

CARDINAL FUNDING:

CARDINAL FUNDING, LLC, a
Utah limited liability company

By: *[Signature]*
Name: JOHN R. THACKERAY
Title: MANAGER

CARDINAL FUNDING ACKNOWLEDGMENT

STATE OF UTAH)
CITY OF Utah) :§.

On the 5 day of February, 2024, personally appeared before me John R. Thackeray, who being by me duly sworn, did say that he is the Manager of Cardinal Funding, LLC, and that the foregoing instrument was duly authorized by the company at a lawful meeting held by authority of its operating agreement and signed in behalf of said company.

Gaylynn Hart
NOTARY PUBLIC



CITY:

Heber City, a political subdivision of the State of Utah

Heidi Franco
Heidi Franco, Mayor



Approved as to form and legality:

Attest:

City Attorney

City Recorder

By: [Signature]

By: Trina N Cooke

CITY ACKNOWLEDGMENT

STATE OF UTAH)
)
:§.
CITY OF HEBER)

On the 4th day of March, 2024, personally appeared before me Heidi Franco, who being by me duly sworn, did say that she is the Mayor of City of Heber, a political subdivision of the State of Utah, and that said instrument was signed in behalf of the City by authority of its governing body.

Trina N Cooke
NOTARY PUBLIC

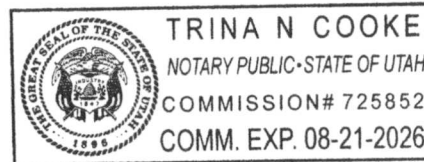

CONSENT AND ACKNOWLEDGMENT OF LANDOWNERS

Each of the undersigned Landowners hereby: (a) confirms and acknowledges such Landowner's receipt of this Amendment and confirms that the Agreement, as amended by this Amendment, is in full force and effect with respect to the to the properties owned by such Landowner and located within the Property; and (b) consents and agrees to abide by the terms and conditions of the Agreement, as amended pursuant to this Amendment, each to the extent applicable to the properties owned by such Landowner.

LANDOWNERS:

Thackeray Family Holdings II, LLC, a Utah limited liability company

By: [Signature]
Name: John R. Thackeray
Title: Manager

Date of Execution: 2/5, 2024

STATE OF UTAH)

CITY OF Utah)

:§.

On the 5 day of February, 2024, personally appeared before me John R. Thackeray, who being by me duly sworn, did say that he is the Manager of Thackeray Family Holding II, LLC, and that the foregoing instrument was duly authorized by the company at a lawful meeting held by authority of its operating agreement and signed in behalf of said company.

[Signature]
NOTARY PUBLIC



Johansen Family Holdings II, LLC, a Utah limited liability company

By: Armand D. Johansen
Name: Armand D. Johansen
Title: Manager

Date of Execution: Feb. 5, 2024

STATE OF UTAH)
CITY OF Utah) :§.

On the 5 day of February 2024, personally appeared before me Armand D. Johansen who being by me duly sworn, did say that he is the Manager of Johansen Family Holdings II, LLC, and that the foregoing instrument was duly authorized by the company at a lawful meeting held by authority of its operating agreement and signed in behalf of said company.

Gaylynn Hart
NOTARY PUBLIC



**Exhibit A
to
Third Amendment
to
Development Agreement for Highlands Master Planned Community**

(Description of Property)

[See attached.]

NORTH PARCEL:

A PARCEL OF LAND LOCATED IN THE NORTHEAST QUARTER OF THE SOUTHEAST QUARTER OF SECTION 19 AND THE WEST HALF OF SECTION 20 ALL IN TOWNSHIP 3 SOUTH, RANGE 5 EAST, SALT LAKE BASE AND MERIDIAN, WASATCH COUNTY, UTAH DESCRIBED AS FOLLOWS:

BEGINNING AT THE INTERSECTION OF THE NORTHERLY RIGHT-OF-WAY LINE OF COMMONS BOULEVARD AND THE EASTERLY RIGHT-OF-WAY LINE OF STATE HIGHWAY 40 PROJECT NO. F-019-1(1), SAID INTERSECTION BEING EAST 214.59 FEET AND SOUTH 1260.57 FEET FROM THE 2005 WASATCH COUNTY SURVEY ALUMINUM PIPE CAP MONUMENT MARKING THE WEST QUARTER CORNER OF SECTION 20, TOWNSHIP 3 SOUTH, RANGE 5 EAST, SALT LAKE BASE AND MERIDIAN (BASIS OF BEARINGS FOR THIS DESCRIPTION IS SOUTH 04°04'03" EAST 2857.85 FEET ALONG A LINE DEFINED BY WASATCH COUNTY WATER SERVICE AREA NO. 1 SURVEY CONTROL MONUMENTS NO. 706 AND NO. 708 (BOTH ALUMINUM PIPE CAP MONUMENTS) SEE THE SURVEY CONTROL SHEET FOR THE CENTRAL UTAH WATER CONSERVANCY DISTRICT, WASATCH COUNTY WATER EFFICIENCY PROJECT, DRAWING NO. G-8 AS RECORDED IN BOOK 630 AT PAGES 766-767 AND AS ENTRY NO. 259146 OF THE WASATCH COUNTY RECORDS); THENCE ALONG SAID EASTERLY RIGHT-OF-WAY LINE NORTH 32°00'02" WEST 1,057.48 FEET TO THE SOUTHEASTERLY LINE OF PARCEL 2 AS DESCRIBED IN THAT WARRANTY DEED TO UTAH VALLEY STATE COLLEGE RECORDED AS ENTRY NO. 333087 OF SAID RECORDS AND ALSO DESCRIBED ON RECORD OF SURVEY NO. OWC-035-019-0-1157 AS FILED IN THE WASATCH COUNTY SURVEYORS OFFICE; THENCE ALONG SAID SOUTHEASTERLY LINE THE FOLLOWING TWO COURSES (1) NORTH 58°00'22" EAST 1,112.69 FEET (NORTH 57°59'34" EAST 1,111.85 FEET BY RECORD); AND (2) NORTH 48°11'59" EAST 1,098.03 FEET (NORTH 48°11'11" EAST 1,097.66 FEET BY RECORD) TO THE CENTERLINE OF THE TIMPANOGOS CANAL AS DESCRIBED IN THAT CONTRACT AND GRANT OF EASEMENT RECORDED AS ENTRY NO. 212641 OF SAID RECORDS; THENCE ALONG SAID CENTERLINE THE FOLLOWING NINE COURSES: (1) NORTH 17°22'52" WEST 54.83 FEET (NORTH 17°22'52" WEST 54.71 FEET PER SAID PARCEL 2); (2) NORTHWESTERLY 62.66 FEET ALONG A 57.21 FEET RADIUS CURVE TO THE LEFT THROUGH A CENTRAL ANGLE OF 62°45'14" AND A LONG CHORD OF NORTH 48°45'29" WEST 59.57 FEET; (3) NORTH 80°08'06" WEST 50.43 FEET; (4) NORTHWESTERLY 80.09 FEET ALONG A 77.16 FEET RADIUS CURVE TO THE RIGHT THROUGH A CENTRAL ANGLE OF 59°28'06" AND A LONG CHORD OF NORTH 50°24'03" WEST 76.54 FEET; (5) NORTH 20°40'00" WEST 67.54 FEET TO STA 212+38 OF SAID TIMPANOGOS CANAL WHICH STA 212+38 IS SOUTH 1318.48 FEET AND EAST 1244.36 FEET FROM THE 1976 WASATCH COUNTY BRASS CAP MONUMENT FOR THE NORTHWEST CORNER OF SECTION 20 PER PARCEL NO. WCWEP-T-0584(P) OF SAID ENTRY NO. 212641; (6) CONTINUING NORTH 20°40'00" WEST 39.32 FEET; (7) NORTHWESTERLY 26.35 FEET ALONG A 73.32 FEET RADIUS CURVE TO THE LEFT THROUGH A CENTRAL ANGLE OF 20°35'35" AND A LONG CHORD OF NORTH 30°57'47" WEST 26.21 FEET; (8) NORTH 41°15'35" WEST 114.29 FEET; AND (9) NORTHWESTERLY 11.22 FEET ALONG A 3,029.45 FEET RADIUS CURVE TO THE RIGHT THROUGH A CENTRAL ANGLE OF 00°12'44" AND A LONG CHORD OF NORTH 41°09'13" WEST 11.22 FEET TO AN EXISTING FENCE; THENCE ALONG SAID EXISTING FENCE SOUTH 89°54'54" EAST 1,524.20 FEET TO THE NORTH-SOUTH CENTER SECTION LINE OF SAID SECTION 20; THENCE ALONG SAID NORTH-SOUTH CENTER SECTION LINE SOUTH 00°00'09" WEST 1,774.05 FEET TO THE

CENTERLINE OF THE SAID TIMPANOGOS CANAL; THENCE ALONG SAID CENTERLINE THE FOLLOWING EIGHT COURSES: (1) NORTH $10^{\circ}34'34''$ WEST 26.14 FEET; (2) NORTHERLY 18.66 FEET ALONG A 63.10 FEET RADIUS CURVE TO THE LEFT THROUGH A CENTRAL ANGLE OF $16^{\circ}56'26''$ AND A LONG CHORD OF NORTH $19^{\circ}02'47''$ WEST 18.59 FEET TO STA 236+55 OF SAID TIMPANOGOS CANAL WHICH STA 236+55 IS NORTH 2238.88 FEET AND WEST 10.76 FEET FROM THE 2005 WASATCH COUNTY ALUMINUM PIPE CAP MONUMENT FOR THE SOUTH QUARTER CORNER OF SECTION 20 PER SAID PARCEL NO. WCWEP-T-0584(P) OF SAID ENTRY NO. 212641; (3) CONTINUING NORTHWESTERLY 31.79 FEET ALONG SAID 63.10 FEET RADIUS CURVE TO THE LEFT THROUGH A CENTRAL ANGLE OF $28^{\circ}51'57''$ AND A LONG CHORD OF NORTH $41^{\circ}56'59''$ WEST 31.45 FEET; (4) NORTH $56^{\circ}22'57''$ WEST 51.03 FEET; (5) NORTHWESTERLY 56.42 FEET ALONG A 130.89 FEET RADIUS CURVE TO THE RIGHT THROUGH A CENTRAL ANGLE OF $24^{\circ}41'49''$ AND A LONG CHORD OF NORTH $44^{\circ}02'03''$ WEST 55.98 FEET; (6) NORTH $31^{\circ}41'08''$ WEST 60.09 FEET; (7) NORTHWESTERLY 126.00 FEET ALONG A 664.07 FEET RADIUS CURVE TO THE LEFT THROUGH A CENTRAL ANGLE OF $10^{\circ}52'18''$ AND A LONG CHORD OF NORTH $37^{\circ}07'17''$ WEST 125.82 FEET; AND (8) NORTH $42^{\circ}33'26''$ WEST 8.76 FEET TO THE NORTH LINE OF PARCEL 1 DESCRIBED IN A WARRANTY DEED RECORDED AS ENTRY NO. 462588 OF SAID RECORDS (WHICH SAID PARCEL 1 IS THE SAME AS PARCEL 4 AS DEPICTED ON A RECORD OF SURVEY MAP PREPARED BY EVERGREEN ENGINEERING FILED AS NO. OWC-035-020-0-881 IN THE WASATCH COUNTY SURVEYORS OFFICE, WHICH BEARINGS ARE ROTATED $0^{\circ}00'48''$ CLOCKWISE TO AGREE WITH THE ABOVE DESCRIBED BASIS OF BEARINGS); THENCE ALONG SAID NORTH LINE NORTH $89^{\circ}59'12''$ WEST 303.12 FEET (WEST BY DEED) TO THE NORTHWEST CORNER OF SAID PARCEL 1; THENCE ALONG THE WEST LINE OF SAID PARCEL 1 SOUTH $00^{\circ}00'48''$ WEST 425.00 FEET (SOUTH BY DEED) TO AN EXISTING EVERGREEN ENGINEERING REBAR & CAP AND THE NORTHWEST CORNER OF PARCEL 2 OF SAID WARRANTY DEED (WHICH SAID PARCEL 2 IS THE SAME AS QUIT CLAIM #2 AS DEPICTED ON A RECORD OF SURVEY MAP PREPARED BY BUHLER ASSOCIATES FILED AS NO. 0001830 IN THE WASATCH COUNTY SURVEYORS OFFICE); THENCE ALONG THE WEST LINE OF SAID QUIT CLAIM #2 SOUTH $00^{\circ}32'12''$ EAST 134.12 FEET (SOUTH BY DEED) TO AN EXISTING BUHLER ASSOCIATES REBAR & CAP; THENCE ALONG THE SOUTH LINE OF SAID QUIT CLAIM #2 NORTH $89^{\circ}49'38''$ EAST 528.67 FEET (EAST BY DEED) EXTENDING THROUGH AN EXISTING BUHLER ASSOCIATES REBAR & CAP TO SAID NORTH-SOUTH CENTER SECTION LINE; THENCE ALONG SAID NORTH-SOUTH CENTER SECTION LINE SOUTH $00^{\circ}00'09''$ WEST 1,263.25 FEET TO A BING CHRISTENSEN REBAR & CAP AS DEPICTED ON A RECORD OF SURVEY MAP PREPARED BY MCM ENGINEERING AND FILED AS NO. 1033 IN SAID WASATCH COUNTY SURVEYOR'S OFFICE; THENCE ALONG AN EXISTING FENCE NORTH $89^{\circ}59'12''$ WEST 676.35 FEET TO STATION 154+09 ON THE CENTERLINE OF THE WASATCH CANAL AS DESCRIBED IN SAID CONTRACT AND GRANT OF EASEMENT RECORDED AS ENTRY NO. 212641 OF SAID RECORDS, SAID POINT BEING 676.32 FEET WEST AND 668.13 FEET NORTH OF THE SOUTH QUARTER CORNER OF SAID SECTION 20; THENCE CONTINUING NORTH $89^{\circ}59'12''$ WEST 52.77 FEET TO THE WESTERLY LINE OF SAID WASATCH CANAL; THENCE ALONG SAID WESTERLY LINE THE FOLLOWING FOURTEEN COURSES: (1) NORTHWESTERLY 36.10 FEET ALONG A 180.84 FEET RADIUS NON-TANGENT CURVE TO THE RIGHT THROUGH A CENTRAL ANGLE OF $11^{\circ}26'10''$ AND A LONG CHORD OF NORTH $48^{\circ}19'44''$ WEST 36.04 FEET; (2) NORTH $42^{\circ}36'39''$ WEST 243.31 FEET; (3) NORTHWESTERLY 59.37 FEET ALONG A 244.36 FEET RADIUS CURVE TO THE LEFT THROUGH A CENTRAL ANGLE OF $13^{\circ}55'16''$

AND A LONG CHORD OF NORTH 49°34'17" WEST 59.23 FEET; (4) NORTH 56°31'55" WEST 141.96 FEET; (5) NORTHWESTERLY 52.18 FEET ALONG A 139.48 FEET RADIUS CURVE TO THE RIGHT THROUGH A CENTRAL ANGLE OF 21°26'10" AND A LONG CHORD OF NORTH 45°48'50" WEST 51.88 FEET; (6) NORTH 35°05'45" WEST 32.66 FEET; (7) NORTHWESTERLY 24.90 FEET ALONG A 52.16 FEET RADIUS CURVE TO THE LEFT THROUGH A CENTRAL ANGLE OF 27°21'17" AND A LONG CHORD OF NORTH 48°46'23" WEST 24.67 FEET; (8) NORTH 62°27'02" WEST 31.01 FEET; (9) NORTHWESTERLY 59.68 FEET ALONG A 100.00 FEET RADIUS CURVE TO THE RIGHT THROUGH A CENTRAL ANGLE OF 34°11'34" AND A LONG CHORD OF NORTH 45°21'15" WEST 58.80 FEET; (10) NORTH 28°15'28" WEST 46.48 FEET; (11) NORTHWESTERLY 27.92 FEET ALONG A 75.00 FEET RADIUS CURVE TO THE LEFT THROUGH A CENTRAL ANGLE OF 21°19'55" AND A LONG CHORD OF NORTH 38°55'26" WEST 27.76 FEET; (12) NORTH 49°35'23" WEST 30.70 FEET; (13) NORTHWESTERLY 89.92 FEET ALONG A 200.95 FEET RADIUS CURVE TO THE RIGHT THROUGH A CENTRAL ANGLE OF 25°38'22" AND A LONG CHORD OF NORTH 36°46'12" WEST 89.18 FEET; AND (14) NORTH 23°57'01" WEST 0.10 FEET TO THE SOUTHERLY RIGHT-OF-WAY LINE OF COMMONS BOULEVARD PER WASATCH COMMONS SUBDIVISION PHASE 1 RECORDED AS ENTRY NO. 362478 OF SAID RECORDS, WHICH SAID PHASE 1 BEARINGS ARE ROTATED 0°01'39" COUNTERCLOCKWISE TO AGREE WITH THE ABOVE DESCRIBED BASIS OF BEARINGS; THENCE ALONG SAID SOUTHERLY RIGHT-OF-WAY LINE THE FOLLOWING TWO COURSES: (1) WESTERLY 252.73 FEET ALONG A 483.50 FEET RADIUS NON-TANGENT CURVE TO THE RIGHT THROUGH A CENTRAL ANGLE OF 29°56'58" AND A LONG CHORD OF NORTH 75°05'36" WEST 249.86 FEET; AND (2) NORTH 60°07'07" WEST 29.46 FEET; THENCE NORTH 29°52'53" EAST 67.00 FEET TO THE NORTHERLY RIGHT-OF-WAY LINE OF SAID COMMONS BOULEVARD; THENCE ALONG SAID NORTHERLY RIGHT-OF-WAY LINE THE FOLLOWING EIGHTEEN COURSES (1) NORTH 60°07'07" WEST 50.00 FEET; (2) NORTHWESTERLY 13.57 FEET ALONG A 17.50 FEET RADIUS CURVE TO THE RIGHT THROUGH A CENTRAL ANGLE OF 44°24'55" AND A LONG CHORD OF NORTH 37°54'40" WEST 13.23 FEET; (3) NORTH 60°07'07" WEST 103.22 FEET; (4) WESTERLY 391.17 FEET ALONG A 488.50 FEET RADIUS CURVE TO THE LEFT THROUGH A CENTRAL ANGLE OF 45°52'49" AND A LONG CHORD OF NORTH 83°03'31" WEST 380.80 FEET; (5) WESTERLY 30.50 FEET ALONG A 35.50 FEET RADIUS REVERSE CURVE TO THE RIGHT THROUGH A CENTRAL ANGLE OF 49°13'32" AND A LONG CHORD OF NORTH 81°23'10" WEST 29.57 FEET; (6) WESTERLY 50.41 FEET ALONG A 94.50 FEET RADIUS REVERSE CURVE TO THE LEFT THROUGH A CENTRAL ANGLE OF 30°33'53" AND A LONG CHORD OF NORTH 72°03'20" WEST 49.82 FEET; (7) NORTHWESTERLY 34.27 FEET ALONG A 35.50 FEET RADIUS REVERSE CURVE TO THE RIGHT THROUGH A CENTRAL ANGLE OF 55°18'12" AND A LONG CHORD OF NORTH 59°41'11" WEST 32.95 FEET; (8) NORTH 32°02'05" WEST 11.88 FEET; (9) SOUTH 50°08'15" WEST 77.72 FEET; (10) SOUTH 32°02'05" EAST 1.29 FEET; (11) SOUTHERLY 34.27 FEET ALONG A 35.50 FEET RADIUS CURVE TO THE RIGHT THROUGH A CENTRAL ANGLE OF 55°18'12" AND A LONG CHORD OF SOUTH 04°22'59" EAST 32.95 FEET; (12) SOUTHERLY 26.91 FEET ALONG A 94.50 FEET RADIUS REVERSE CURVE TO THE LEFT THROUGH A CENTRAL ANGLE OF 16°18'53" AND A LONG CHORD OF SOUTH 15°06'41" WEST 26.82 FEET; (13) SOUTHWESTERLY 31.61 FEET ALONG A 35.50 FEET RADIUS REVERSE CURVE TO THE RIGHT THROUGH A CENTRAL ANGLE OF 51°00'41" AND A LONG CHORD OF SOUTH 32°27'35" WEST 30.57 FEET; (14) SOUTH 57°57'55" WEST 24.11 FEET; (15) SOUTHWESTERLY 21.44 FEET ALONG A 135.00 FEET RADIUS CURVE TO THE RIGHT THROUGH A CENTRAL ANGLE OF 09°05'55" AND A LONG CHORD OF SOUTH 62°30'53" WEST 21.42 FEET; (16) SOUTH 67°03'50" WEST

52.01 FEET; (17) SOUTHWESTERLY 26.20 FEET ALONG A 165.00 FEET RADIUS CURVE TO THE LEFT THROUGH A CENTRAL ANGLE OF 09°05'55" AND A LONG CHORD OF SOUTH 62°30'53" WEST 26.17 FEET; AND (18) SOUTH 57°57'55" WEST 27.54 FEET TO THE POINT OF BEGINNING.

CONTAINING 6,038,681 SQUARE FEET OR 138.629 ACRES.

SOUTH PARCEL:

A PARCEL OF LAND LOCATED IN THE NORTHEAST QUARTER OF THE SOUTHWEST QUARTER OF SECTION 20 ALL IN TOWNSHIP 3 SOUTH, RANGE 5 EAST, SALT LAKE BASE AND MERIDIAN, WASATCH COUNTY, UTAH DESCRIBED AS FOLLOWS:

BEGINNING AT A POINT ON THE EASTERLY RIGHT-OF-WAY LINE OF STATE HIGHWAY 40 PROJECT NO. F-019-1(1), SAID POINT BEING NORTH 0°08'37" WEST 687.06 FEET ALONG THE SECTION LINE AND EAST 659.19 FEET FROM THE 1999 WASATCH COUNTY SURVEY ALUMINUM CAP MONUMENT MARKING THE SOUTHWEST QUARTER CORNER OF SECTION 20, TOWNSHIP 3 SOUTH, RANGE 5 EAST, SALT LAKE BASE AND MERIDIAN (BASIS OF BEARINGS FOR THIS DESCRIPTION IS SOUTH 04°04'03" EAST 2857.85 FEET ALONG A LINE DEFINED BY WASATCH COUNTY WATER SERVICE AREA NO. 1 SURVEY CONTROL MONUMENTS NO. 706 AND NO. 708 (BOTH ALUMINUM PIPE CAP MONUMENTS) SEE THE SURVEY CONTROL SHEET FOR THE CENTRAL UTAH WATER CONSERVANCY DISTRICT, WASATCH COUNTY WATER EFFICIENCY PROJECT, DRAWING NO. G-8 AS RECORDED IN BOOK 630 AT PAGES 766-767 AND AS ENTRY NO. 259146 OF THE WASATCH COUNTY RECORDS); THE PARCEL 2 DESCRIPTION AS RECORDED AS ENTRY NO. 396936 OF SAID RECORDS, WHICH SAID PARCEL 2 BEARINGS ARE ROTATED 0°01'39" COUNTERCLOCKWISE TO AGREE WITH THE ABOVE DESCRIBED BASIS OF BEARINGS; THENCE ALONG SAID EASTERLY RIGHT OF WAY LINE NORTH 32°00'02" WEST 748.34 FEET ALONG THE EASTERLY RIGHT OF WAY LINE OF SAID STATE HIGHWAY 40 TO THE BOUNDARY LINE OF WASATCH COMMONS SUBDIVISION, SAID BOUNDARY ALSO BEING THE SOUTH RIGHT OF WAY LINE FOR COMMONS BOULEVARD; THENCE ALONG THE SAID SOUTH RIGHT OF WAY LINE AND BOUNDARY LINE NORTH 57°57'55" EAST 146.97 FEET; THENCE NORTHEASTERLY 33.19 FEET ALONG A 35.50 FEET RADIUS CURVE TO THE RIGHT THROUGH A CENTRAL ANGLE OF 53°33'54" AND A LONG CHORD OF NORTH 84°44'52" EAST 31.99 FEET; THENCE SOUTHEASTERLY 31.12 FEET ALONG A 94.50 FEET RADIUS REVERSE CURVE TO THE LEFT THROUGH A CENTRAL ANGLE OF 18°52'06" AND A LONG CHORD OF SOUTH 77°54'14" EAST 30.98 FEET; THENCE SOUTHEASTERLY 34.27 FEET ALONG A 35.50 FEET RADIUS REVERSE CURVE TO THE RIGHT THROUGH A CENTRAL ANGLE OF 55°18'12" AND A LONG CHORD OF SOUTH 59°41'11" EAST 32.95 FEET TO A POINT ON THE WEST RIGHT OF WAY LINE FOR GREEN VALLEY ROAD; THENCE ALONG SAID RIGHT OF WAY LINE AND SAID BOUNDARY LINE SOUTH 32°02'05" EAST 10.00 FEET; THENCE NORTH 57°57'55" EAST 12.00 FEET; THENCE SOUTH 32°02'05" EAST 44.05 FEET; THENCE SOUTHEASTERLY 14.86 FEET ALONG A 153.00 FEET RADIUS CURVE TO THE LEFT THROUGH A CENTRAL ANGLE OF 5°33'55" AND A LONG CHORD OF SOUTH 34°49'02" EAST 14.86 FEET; THENCE SOUTH 37°36'00" EAST 36.75 FEET; THENCE SOUTHEASTERLY 59.80 FEET ALONG A 447.00 FEET RADIUS CURVE TO THE

RIGHT THROUGH A CENTRAL ANGLE OF 7°39'55" AND A LONG CHORD OF SOUTH 33°46'03" EAST 59.76 FEET; THENCE SOUTH 29°56'05" EAST 24.60 FEET; THENCE SOUTHEASTERLY 92.27 FEET ALONG A 2517.50 FEET RADIUS CURVE TO THE LEFT THROUGH A CENTRAL ANGLE OF 2°06'00" AND A LONG CHORD OF SOUTH 30°59'05" EAST 92.26 FEET; THENCE SOUTH 32°02'05" EAST 544.50 FEET; THENCE NORTH 89°59'12" WEST 270.18 FEET TO THE POINT OF BEGINNING.

CONTAINS 185,067 SQUARE FEET OR 4.249 ACRES

Exhibit D to Third Amendment to Development Agreement for Highlands Master Planned Community (Master Plan)



Exhibit L
to
Third Amendment
to
Development Agreement for Highlands Master Planned Community

(NVOZ Specific Application Standards—Highlands Master Planned Community)

Article and Section references are to the General Provisions of the North Village Overlay District Code referenced in the 18.21.010 of the Zone:

Article 3.0 Buildings, Section 3.2, Explanation of Building Standards, 4 Street Façade Requirements, is hereby amended to eliminate the last phrase of the first sentence (i.e., “including a parking lot”) and the second sentence in the introductory paragraph (i.e. 360-degree architecture is not required), provided, however, all facades facing a public or private right-of-way shall satisfy the “Blank Wall Limitations” set forth in sub-party (2) of sub-paragraph 4 (see Exhibit L.1).

Article 3.0 Buildings, Section 3.2, Explanation of Building Standards, 5 Unique Architecture, is hereby amended to reduce the 400-foot distance to 120 feet for lots that are less than a quarter acre in size so long as there are at least 6 different building facades within such 120-foot distance on both sides of the street. A plan for such will be submitted at preliminary approval.

Article 3.0 Buildings, Section 3.2, Explanation of Building Standards, 2 Building Height, Sub-paragraph 2(d), is hereby amended to provide that the stated requirements only apply to adjacent buildings on the same side of the street and facing a public street and to indicate that the height variation requirements do not apply if the natural topography of the site enables a perceived height variation between adjacent buildings. 3 / 4 split buildings shall be treated as 3-story buildings with respect to height variation requirements (see Exhibit L.1).

Exhibit L.1

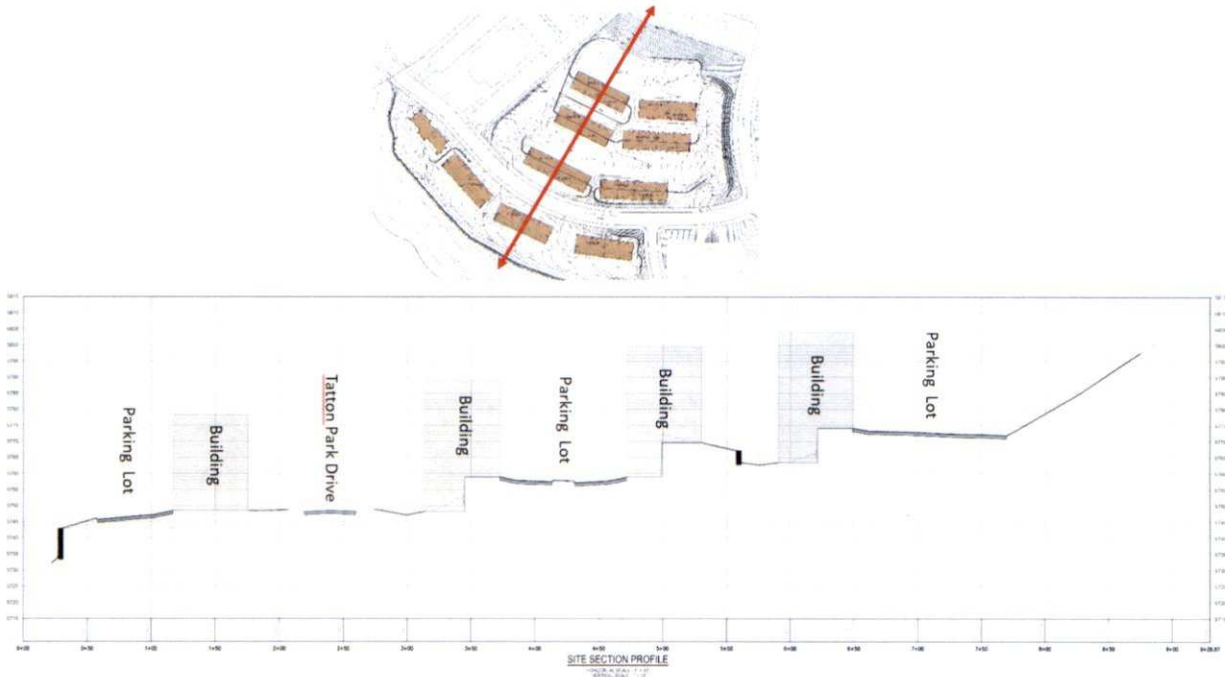

Article 3.0 Buildings, Section 3.6 Townhouse Building, Sub-paragraph 2, Footnote 2, is hereby amended to eliminate the 3-building requirement and to impose a 50-foot average courtyard width requirement where the courtyard is non-linear; provided, in no event shall a non-linear courtyard be less than 30 feet in width at any location (See Exhibit L.2).

Exhibit L.2.

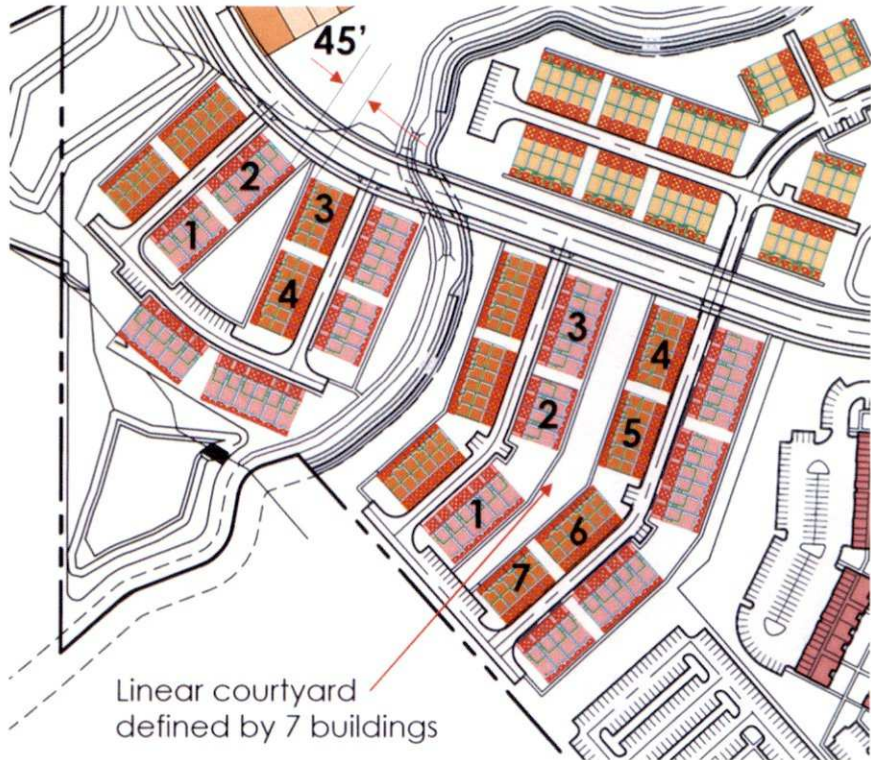

Article 3.0 Buildings, Section 3.9 Craftsman, Sub-paragraph 9, is hereby amended to allow for Front Porches of varying sizes to promote a variation in facades; provided, an exception to the minimum 60 square-foot requirement shall be satisfied by providing a private enclosed courtyard of at least the same size (See Exhibit L.3).

Article 3.0 Buildings, Section 3.10 Farmhouse, Sub-paragraph 7, is hereby amended to allow for Front Porches of varying sizes to promote a variation in facades; provided, an exception to the minimum 60 square-foot requirement shall be satisfied by providing a private enclosed courtyard of at least the same size (See Exhibit L.3).

Article 3.0 Buildings, Section 3.11 Mountain Modern, Sub-paragraph 7, is hereby amended to allow for Front Porches of varying sizes to promote a variation in facades; provided, an exception to the minimum 60 square-foot requirement shall be satisfied by providing a private enclosed courtyard of at least the same size (See Exhibit L.3).

Exhibit L.3

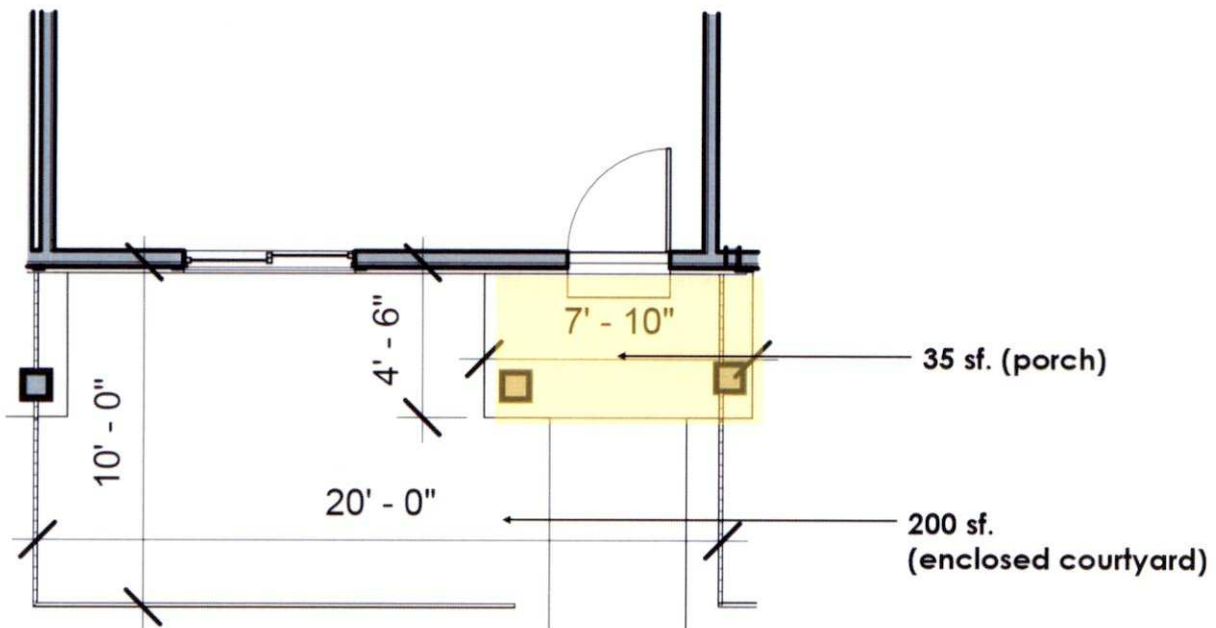

Article 3.0 Buildings, Section 3.6 Townhouse Building, Figure 3.6 (5), is hereby amended to require Townhouses facing common greens to have three-

sided architecture with windows (but not a wrap-around porch), provided, where a townhouse faces another row of townhouses, the façade shall include architectural elements approved by the City planning staff that present a pleasing facade to the facing properties (See Exhibit L.4).

Exhibit L.4

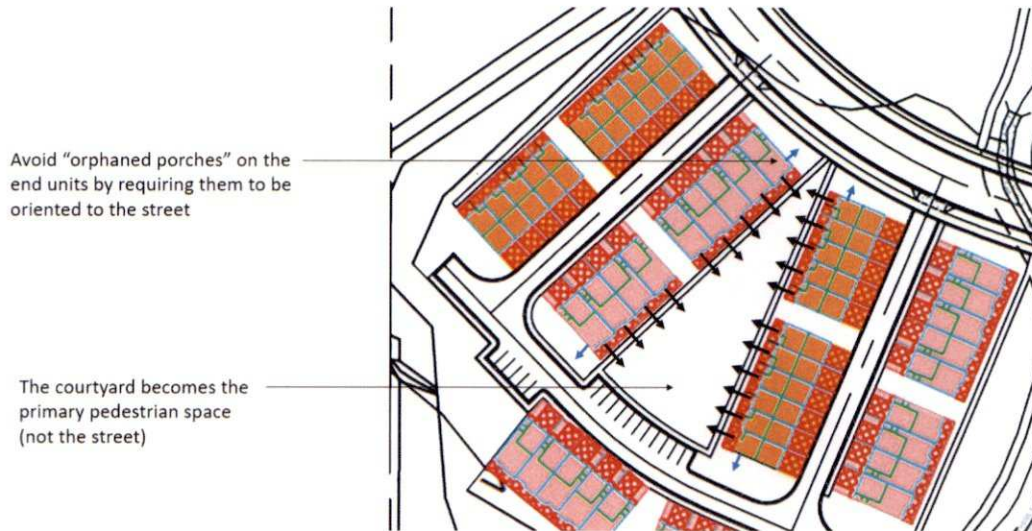

Table 3.4(1), Line a, is hereby amended to allow the City planning staff to reduce the "Front Property Line Coverage" percentage to accommodate site topography and to provide that access drives shall be excluded from the "Front Property Line Coverage" calculation (See Exhibit L.5).

Exhibit L.5

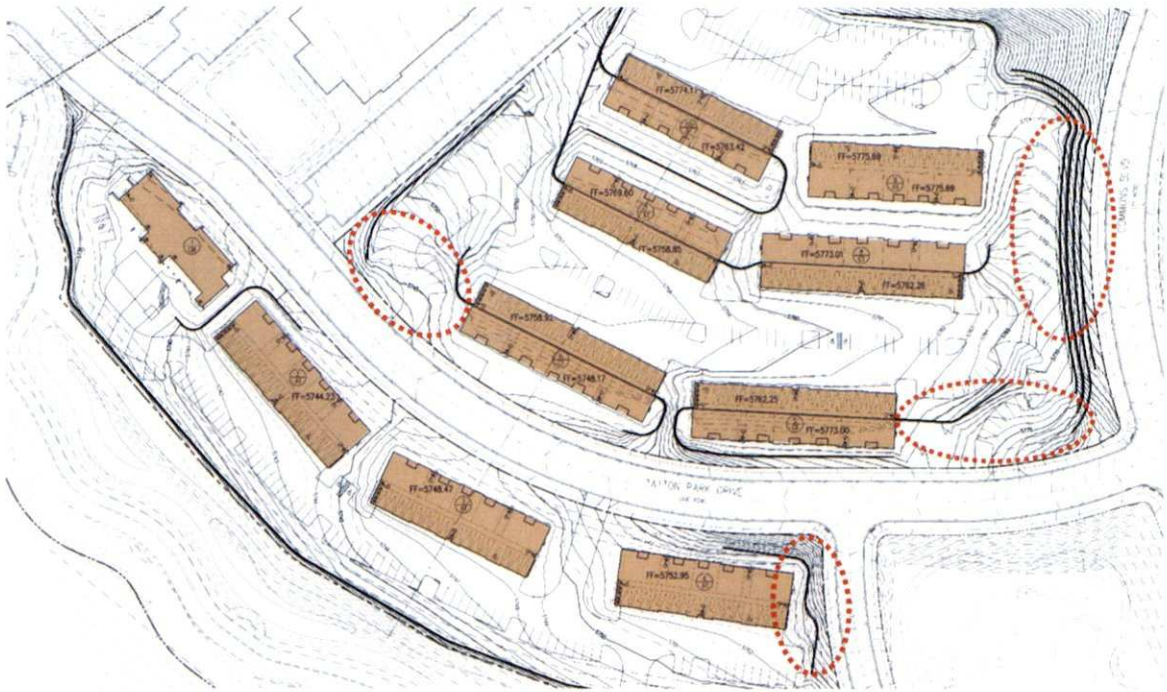

Table 3.4(1), Line b, is hereby amended to allow the City planning staff to increase the “Front Build-to-Zone” requirements to accommodate topography or when the front property line curves such that a 10’-20’ front build-to-zone is not reasonably achievable (See Exhibit L.6).

Exhibit L.6

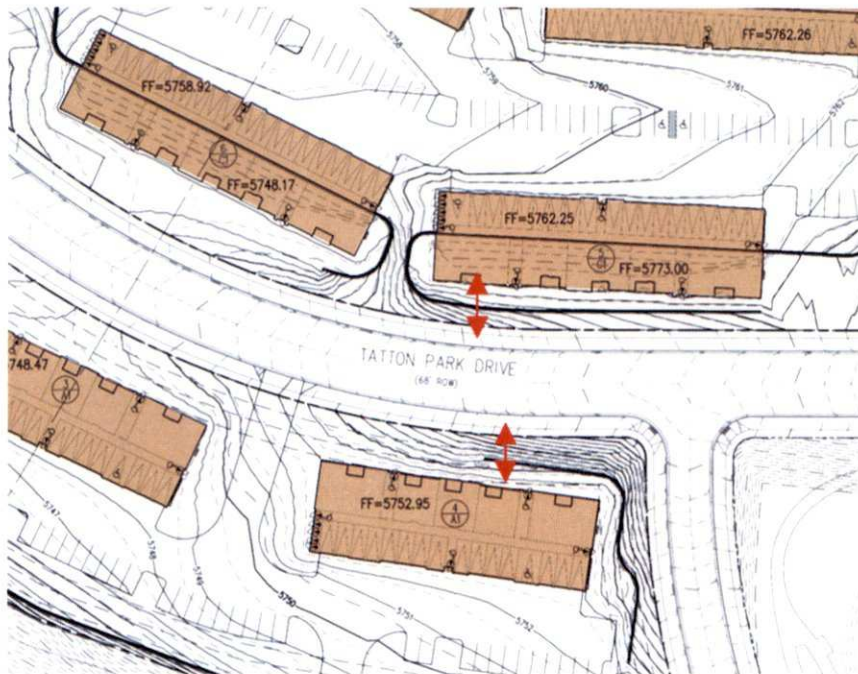

Table 3.7(1), Line I, together with footnote 5, are hereby amended to allow the garage to be set back from the building Façade not less than 2 feet, measured from any floor of the building where one or more of the following design elements are incorporated into the design of the building or street face to reduce visual impact of the garage[s], as approved by the City’s planning department (See examples Exhibit L.7):

1. Utilize private streets for any dwelling with front loaded garages to minimize City burden of plowing and parking enforcement.
2. Require multiple wall planes along the front face of each building Façade.
3. Require a window in each projecting wall plane of the building Façade.
4. Require a 2-foot projection beyond the garage face on the second story of the building.
5. Require alternating (a.k.a. flipped) floor plans from lot to lot to maximize on-street parking. A plan for such will be submitted at preliminary approval.
6. Require differing lot sizes to maximize on-street parking and enhance the feel or architectural mix.
7. Require front door to face the street.
8. Require a covered porch.
9. Require supportive pillars in front of the garage face.
10. Garage doors shall be of varied architectural styles, material and colors and shall include windows, which windows may reasonably vary from home to home in location, size and window type (top, side, clear, opaque, etc.) consistent with the architectural style of the building.

Exhibit L.7



Table 4.2(1), Line I, Maximum Block Perimeter, together with footnote 1, are hereby amended to indicate that block perimeters may be increased by the City's planning department by more than 20% to accommodate the topography of the site, and to allow for increased maximum block perimeters where internal parking lots, and private access drives are proposed to achieve vehicular connectivity and sidewalks, trails or paths are proposed to achieve pedestrian connectivity (See Exhibit L.8).

Exhibit L.8

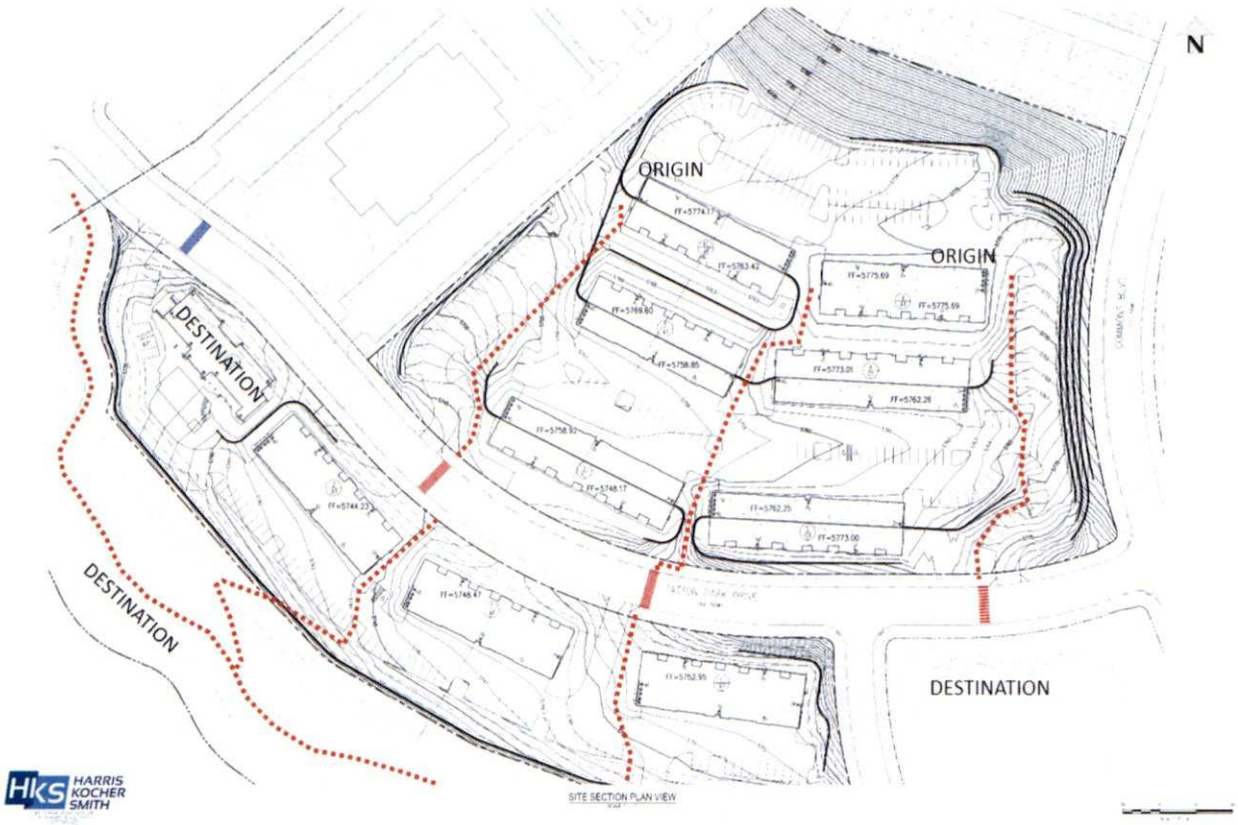

Exhibit M
to
Third Amendment
to
Development Agreement for Highlands Master Planned Community

Parcel 1:

A PARCEL OF LAND LOCATED IN THE NORTHWEST QUARTER OF SECTION 20, IN TOWNSHIP 3 SOUTH, RANGE 5 EAST, SALT LAKE BASE AND MERIDIAN, WASATCH COUNTY, UTAH DESCRIBED AS FOLLOWS:

BEGINNING AT A POINT ON THE NORTH LINE OF THE PROPOSED HIGHLANDS DEVELOPMENT; SAID POINT BEING NORTH 00°29'50" WEST 1307.75 FEET ALONG THE SECTION LINE AND NORTH 89°30'10" EAST 1717.20 FEET FROM THE WASATCH COUNTY SURVEY ALUMINUM PIPE CAP MONUMENT MARKING THE WEST QUARTER CORNER OF SECTION 20, TOWNSHIP 3 SOUTH, RANGE 5 EAST, SALT LAKE BASE AND MERIDIAN; (BASIS OF BEARINGS FOR THIS DESCRIPTION IS SOUTH 04°04'03" EAST 2857.85 FEET ALONG A LINE DEFINED BY WASATCH COUNTY WATER SERVICE AREA NO. 1 SURVEY CONTROL MONUMENTS NO. 706 AND NO. 708 (BOTH ALUMINUM PIPE CAP MONUMENTS) (SEE THE SURVEY CONTROL SHEET FOR THE CENTRAL UTAH WATER CONSERVANCY DISTRICT, WASATCH COUNTY WATER EFFICIENCY PROJECT, DRAWING NO. G-8 AS RECORDED IN BOOK 630 AT PAGES 766-767 AND AS ENTRY NO. 259146 OF THE WASATCH COUNTY RECORDS); AND RUNNING THENCE NORTH 21°24'08" EAST 258.16 FEET; THENCE SOUTH 70°03'55" EAST 252.30 FEET; THENCE SOUTH 26°05'49" EAST 172.53 FEET TO A POINT ON THE NORTH LINE OF THE PROPOSED HIGHLANDS DEVELOPMENT; THENCE NORTH 89°54'54" WEST 407.29 FEET ALONG THE NORTH LINE OF SAID PROPOSED HIGHLANDS DEVELOPMENT TO THE POINT OF BEGINNING.

THE ABOVE DESCRIBED PARCEL CONTAINS: 64,087 SQUARE FEET, OR 1.471 ACRES

Parcel 3:

A PARCEL OF LAND LOCATED IN THE EAST HALF OF SECTION 20, IN TOWNSHIP 3 SOUTH, RANGE 5 EAST, SALT LAKE BASE AND MERIDIAN, WASATCH COUNTY, UTAH DESCRIBED AS FOLLOWS:

BEGINNING AT A POINT ON THE EAST LINE OF THE PROPOSED HIGHLANDS DEVELOPMENT; SAID POINT BEING NORTH 00°29'50" WEST 512.50 FEET ALONG THE SECTION LINE AND NORTH 89°30'10" EAST 2641.36 FEET FROM THE WASATCH COUNTY SURVEY ALUMINUM PIPE CAP MONUMENT MARKING THE WEST QUARTER CORNER OF SECTION 20, TOWNSHIP 3 SOUTH, RANGE 5 EAST, SALT LAKE BASE AND MERIDIAN; (BASIS OF BEARINGS FOR THIS DESCRIPTION IS SOUTH 04°04'03" EAST 2857.85 FEET ALONG A LINE DEFINED BY WASATCH COUNTY WATER SERVICE AREA NO. 1 SURVEY CONTROL MONUMENTS NO. 706 AND NO. 708 (BOTH ALUMINUM PIPE CAP MONUMENTS) (SEE THE SURVEY CONTROL SHEET FOR THE CENTRAL UTAH WATER CONSERVANCY DISTRICT, WASATCH COUNTY WATER EFFICIENCY PROJECT, DRAWING NO. G-8 AS RECORDED IN BOOK 630 AT PAGES 766-767 AND AS ENTRY NO. 259146 OF THE WASATCH COUNTY RECORDS); AND RUNNING THENCE SOUTH 50°47'07" EAST 630.14 FEET; THENCE SOUTH 39°12'53" WEST 160.00 FEET; THENCE SOUTH 48°47'41" WEST 209.84 FEET;

THENCE SOUTH 47°21'15" WEST 58.64 FEET; THENCE SOUTH 11°49'56" EAST 40.21 FEET; THENCE SOUTH 49°46'59" WEST 126.86 FEET; THENCE SOUTH 59°43'42" WEST 112.86 FEET TO A POINT ON THE EAST LINE OF THE PROPOSED HIGHLANDS DEVELOPMENT; THENCE NORTH 0°0'09" EAST 878.48 FEET ALONG SAID EAST LINE TO THE POINT OF BEGINNING.

THE ABOVE DESCRIBED PARCEL CONTAINS: 224,569 SQUARE FEET, OR 5.155 ACRE

Note: The above-referenced Parcels 1 and 3 are depicted on Highlands Residential Land Swap Exhibit, a copy of which is attached to Exhibit N.

Exhibit N
to
Third Amendment
to
Development Agreement for Highlands Master Planned Community

PARCEL 2:

A PARCEL OF LAND LOCATED IN THE NORTHWEST QUARTER OF SECTION 20, IN TOWNSHIP 3 SOUTH, RANGE 5 EAST, SALT LAKE BASE AND MERIDIAN, WASATCH COUNTY, UTAH DESCRIBED AS FOLLOWS:

BEGINNING AT A POINT ON THE EAST LINE OF THE PROPOSED HIGHLANDS DEVELOPMENT; SAID POINT BEING NORTH 00°29'50" WEST 512.50 FEET ALONG THE SECTION LINE AND NORTH 89°30'10" EAST 2641.36 FEET FROM THE WASATCH COUNTY SURVEY ALUMINUM PIPE CAP MONUMENT MARKING THE WEST QUARTER CORNER OF SECTION 20, TOWNSHIP 3 SOUTH, RANGE 5 EAST, SALT LAKE BASE AND MERIDIAN; (BASIS OF BEARINGS FOR THIS DESCRIPTION IS SOUTH 04°04'03" EAST 2857.85 FEET ALONG A LINE DEFINED BY WASATCH COUNTY WATER SERVICE AREA NO. 1 SURVEY CONTROL MONUMENTS NO. 706 AND NO. 708 (BOTH ALUMINUM PIPE CAP MONUMENTS) (SEE THE SURVEY CONTROL SHEET FOR THE CENTRAL UTAH WATER CONSERVANCY DISTRICT, WASATCH COUNTY WATER EFFICIENCY PROJECT, DRAWING NO. G-8 AS RECORDED IN BOOK 630 AT PAGES 766-767 AND AS ENTRY NO. 259146 OF THE WASATCH COUNTY RECORDS);

SAID POINT OF BEGINNING ALSO BEING ON THE SOUTHERLY RIGHT OF WAY LINE OF A PROPOSED COLLECTOR ROAD; AND RUNNING THENCE NORTHERLY ALONG SAID SOUTHERLY RIGHT OF WAY LINE THE FOLLOWING FIVE (5) COURSES & DISTANCES;

- (1) NORTH 50°47'07" WEST 49.30 FEET TO A POINT OF CURVATURE;
 - (2) NORTHWESTERLY 96.86 FEET ALONG THE ARC OF A 384.00 FOOT RADIUS CURVE TO THE RIGHT; CHORD BEARS NORTH 43°33'32" WEST 96.60 FEET;
 - (3) NORTH 36°19'58" WEST 219.31 FEET TO A POINT OF CURVATURE;
 - (4) NORTHWESTERLY 109.47 FEET ALONG THE ARC OF A 384.00 FOOT RADIUS CURVE TO THE RIGHT; CHORD BEARS NORTH 28°09'56" WEST 109.10 FEET;
 - (5) NORTH 19°59'55" WEST 438.90 FEET;
- THENCE SOUTH 89°54'54" EAST 436.34 FEET; THENCE SOUTH 00°00'09" WEST 785.83 FEET TO THE POINT OF BEGINNING.

THE ABOVE DESCRIBED PARCEL CONTAINS: 209,989 SQUARE FEET, OR 4.820 ACRES

Note: The above-referenced Parcels 2 is depicted on Highlands Residential Land Swap Exhibit, a copy of which is attached to this Exhibit N.

Exhibit O
to
Third Amendment
to
Development Agreement for Highlands Master Planned Community

Water Feature Details

[See attached.]

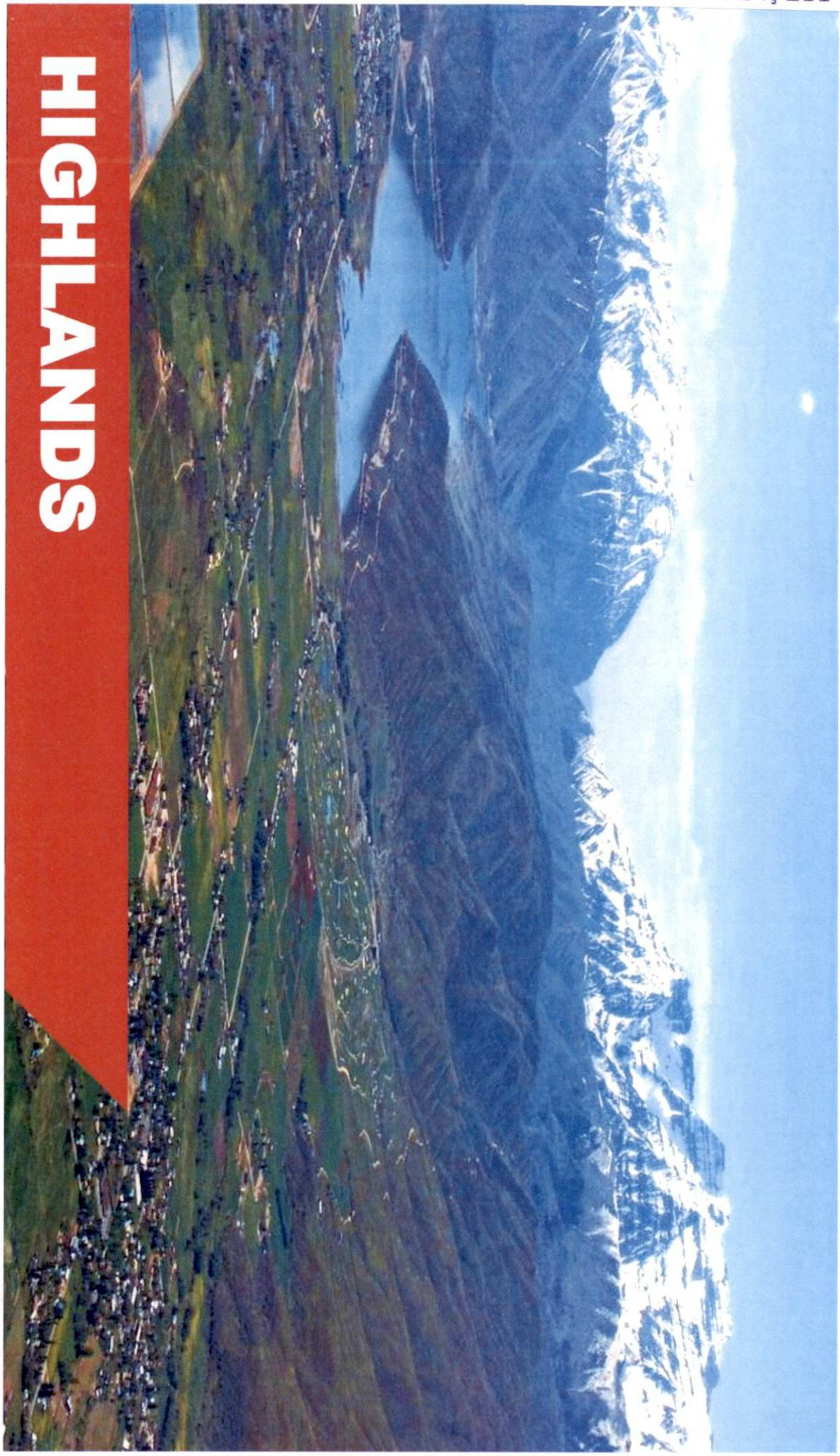

HIGHLANDS

CREEKSIDE AT HIGHLANDS

Master Plan Amendment

DATE: Tuesday September 20, 2022



Highlands

HEBER CITY • UTAH

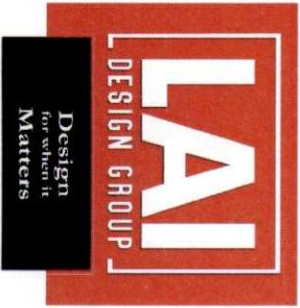

HIGHLANDS ONSITE DRAINAGE PLAN



- LEGEND:**
- ON SITE RETENTION POND
 - OFF SITE RETENTION POND
 - MIXED ONSITE / OFFSITE
 - DETENTION POND FOR EXISTING ON SITE APARTMENTS

GENERAL NOTES:
 1. PIPES SHOWN THROUGH THE TOWN CENTER CAN BE EITHER 36" PIPE OR AN OPEN CHANNEL TO BE DETERMINED THROUGH THE TOWN CENTER PLANNING ANALYSIS

TABLE 1: POND ANALYSIS

Pond	Flow Criteria	Designed Pond Capacity (ACFT) ¹	On-site/Off-site Total Pond Capacity (No Infiltration) ²	Infiltration Rate (in/hr)	Pond Infiltration (CFES)	Off-site Req'd Pond Capacity ³	On-site Req'd Calculated Pond Capacity ⁴	Total Pond Capacity (with Infiltration)
1	OFF-SITE	0.57	0.57	2.00	0.79	0.57	0.00	0.57
2	OFF-SITE	0.48	0.48	2.00	0.29	0.48	0.00	0.48
6	OFF-SITE	1.62	1.62	2.00	0.75	1.62	0.00	1.62
7	OFF-SITE	2.70	2.70	2.00	1.16	2.70	0.00	2.70
8	ONS-SITE	2.05	2.70	2.00	1.33	0.00	1.90	1.90
9	ONS-SITE	0.80	0.80	2.00	0.50	0.00	0.63	0.63
10	ONS-SITE	0.49	3.11	2.00	0.27	0.00	3.09	3.09
11	ONS-SITE	1.81	2.14	2.00	1.12	0.00	1.63	1.63
12	MIXED	3.20	0.74	2.00	2.10	2.84	0.26	3.10
13	ONS-SITE	1.02	1.34	2.00	0.63	0.00	1.05	1.05
14	MIXED	5.29	1.88	2.00	3.08	0.00	0.92	0.92
15	MIXED	5.55	4.08	2.00	3.58	0.00	2.76	2.76
16	ONS-SITE	0.23	0.66	2.00	0.14	0.00	0.20	0.20
17	ONS-SITE	0.42	0.72	2.00	0.25	0.00	0.60	0.60
18	ONS-SITE	0.43	1.22	2.00	0.26	0.00	1.13	1.13
TOTAL		26.66	24.61		16.26	8.21	14.16	22.37

¹ On-site required pond capacity calculated with an infiltration rate of 2 in/hr
² This is based on preliminary grading of Highlands
³ This is the required/calculated capacity of the pond based on a 100 year - 24 hour storm event.
⁴ This is the off-site pond capacity required per the Heber City Master Plan North Village Storm Water Design Manual

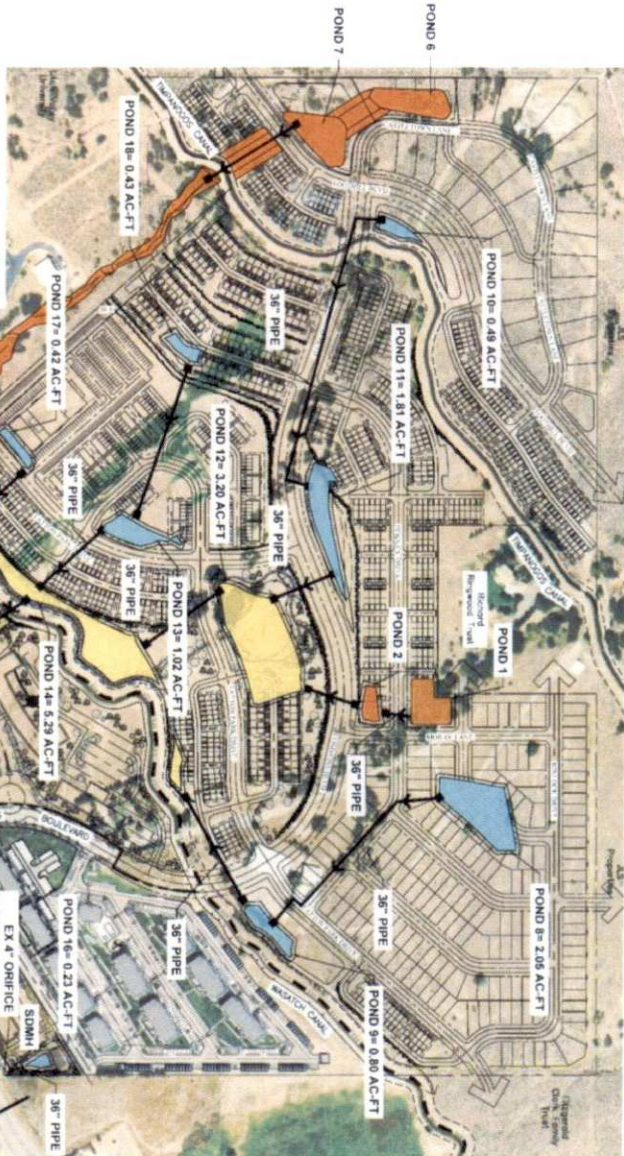

US HIGHWAY 40

100' ON-SITE CHANNEL

36" PIPE OR OPEN CHANNEL SEE NOTE #1

EXISTING 30" SD PIPE ACROSS THE US 40 Q PIPE = 20:00:08 HWD = 1:00 SLOPE = 1.08 %

EXISTING APARTMENT POND= 20 CFS RELEASE

EX 4" ORIFICE FOR APARTMENTS

SDMH

EX-01B

27 West 800 South, Salt Lake City, Utah 84111

Ward Engineering Group

Planning Engineering Surveying

PH: 303.467.8980

HIGHLANDS

WASATCH COUNTY, UTAH

ON SITE RETENTION

**HIGHLANDS
PARK MASTER PLAN**

Linear Park = 6.95 AC
Original Park = 4.85 AC



HIGHLANDS
LINEAR PARK RENDERING

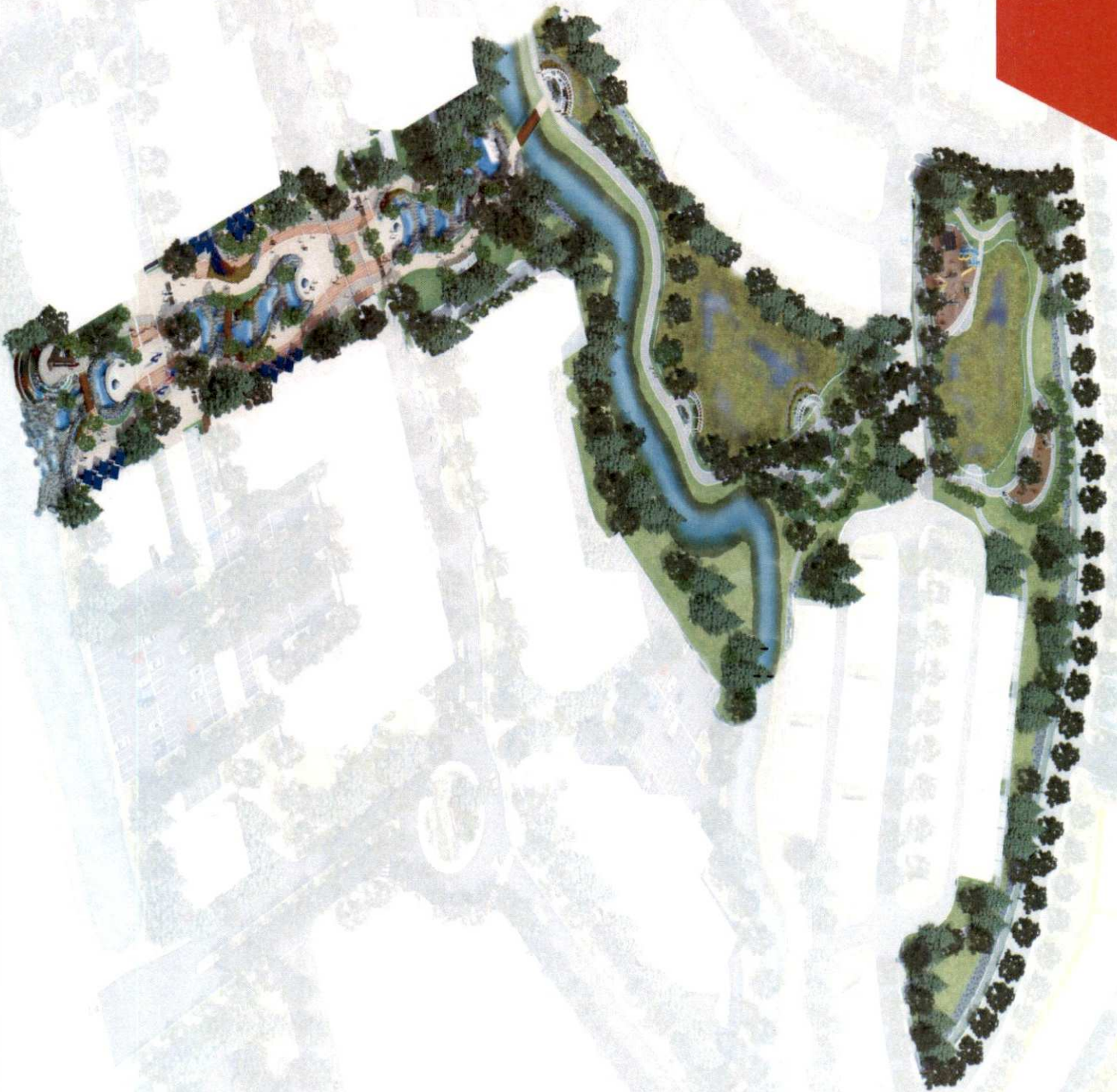

HIGHLANDS LINEAR PARK ENLARGEMENT



HIGHLANDS LINEAR PARK – 5 PARK ELEMENTS

Linear Park

- 6.95 acres of the required 43.47 acres per the Master Development Agreement. Original Neighborhood Park = 4.85 acres
- Pursuant to the standards outlined in Section 5.0 Parks, Trails & Natural Lands Preservation of the NVOZ
- Exact layout of following elements is subject to change.

Highlands Park

- Adventure Park (6-10 years old)
- Tot Lot (2-6 years old)
- Active Lawn Play
- Restrooms
- Pavilions
- Wildflower, Butterfly, & Hummingbird Basins
- Overlooks with Interpretive/Informational Signage
- Trailhead

Brookside Park

- Water Wall
- Pedestrian Bridge
- Shade Shelter
- Cascading Water Feature w/ Check Dams
- Overlook Platform
- Sculptures
- Passive Lawn Area
- Landscape Steps
- Specialty Paving

Ceremony Plaza

- Flagpoles
- Monument Signs
- Cascading Water Features w/ Check Dams
- Overlook Platform
- Specialty Paving
- Sculptures
- Pedestrian Bridges
- Plaza
- Waterfall

Wasatch Greenway

- Trailhead(s)
- Water Filling Stations
- Crusher Fines Trail
- Arbors
- Reading Nooks
- Sensory/Music Gardens
- Pavillion

Creekside Plaza

- Cascading Water Features w/ Check Dams
- Overlook Platform
- Specialty Paving
- Sculptures
- Pedestrian Bridges
- Plaza
- Ample Seating and Gathering Space

HIGHLANDS NVOZ BASIC AMENITY LIST

PARK AND OPEN SPACE AMENITIES

BASIC AMENITY	REQUIREMENTS
Park Bench	1 per 1/4 mile of paved or gravel trail, 4 per first 1/2 acre and 2 additional per acre for Urban Gathering Places, Local, and larger parks
Water Stations	Minimum 1 per Urban Gathering Places, 1 per park amenity node (pavilions, bathrooms, etc.) for larger parks
Pavilion	Minimum one per Plaza, Square, Local Parks (15 person size), 2 per 3 acres of park for Neighborhood/Community Parks (50 person)
Playground	Minimum one per Local and 1 per 10 acres for larger parks
Picnic Area	Minimum 1 per Local and larger parks, Minimum 4 tables, 2 barbecues, shade, hard surfacing
Restrooms	1 per Neighborhood and larger parks (interior & exterior lighting)
Amenity Options	
Baseball Field	1 baseball field
Softball Field	1 softball field
Passive Lawn	Well graded 1/2 acre of turf grass lawn with 5-10 large park trees per acre
Sports field	1 multi sport field (soccer lacrosse, rugby, etc)
Tennis courts	2 Tennis Courts
Pickleball courts	4 Pickleball Courts
Outdoor Basketball	1 Outdoor Concrete Basketball Court
Outdoor Pool	1 Outdoor Pool
Rec Center	1 Recreation Center
Community Center	1 Community Center
Trail Options	See Parks and Trails Master Plan for standards
Trail Head	1 Trailhead Sign and 10 Parking Stalls, 1 water station to include equestrian water access, 1 per 1/4 mile includes a combination of physical/active stations and activity signs
Fitness system nodes	Trail directional sign at all trail intersections
On Trail Sign	

Table 5.1 (1). Area Park Open Space Requirements by Sub-District

Qualifying Uses for Parks and Open Space			Meets Park Requirements	Meets Open Space Requirements
Use				
Trails within Parks	Yes		Yes	
Trails in Open Space	No		No	Yes
Ball Courts	Yes		Yes	Yes
Farm or Agricultural Lands	No		No	Yes
Stormwater for Parks ^a	Yes		Yes	Yes
Stormwater for Development ^a	No		No	Yes
Stormwater in Common Areas ^a	No		No	Yes
Parking for Parks	Yes		Yes	Yes
Plazas, Courtyard, Park	Yes		Yes	Yes
Pocket Park, Community Park	Yes		Yes	Yes
Landscape around Private Buildings	No		No	Yes See # 14
Recreation Center Buildings	Yes		Yes	Yes
Agriculture Buildings	No		No	No
Rooftop Gardens ^b	Partial		Partial	Partial
Playgrounds	Yes		Yes	Yes
Common Areas for Developments	Yes		Yes	Yes
Amphitheater	Yes		Yes	Yes
Sports fields	Yes		Yes	Yes
Community pools & pool areas	Yes		Yes	Yes
Sensitive Lands Preserved ^c	Yes		Yes	Yes
Recreation Center	Yes		Yes	Yes

Note: For illustrative purposes only. Final design is subject to change.

**HIGHLANDS
CREEKSIDE ENLARGEMENT**



HIGHLANDS
TOWN CENTER ENLARGEMENT

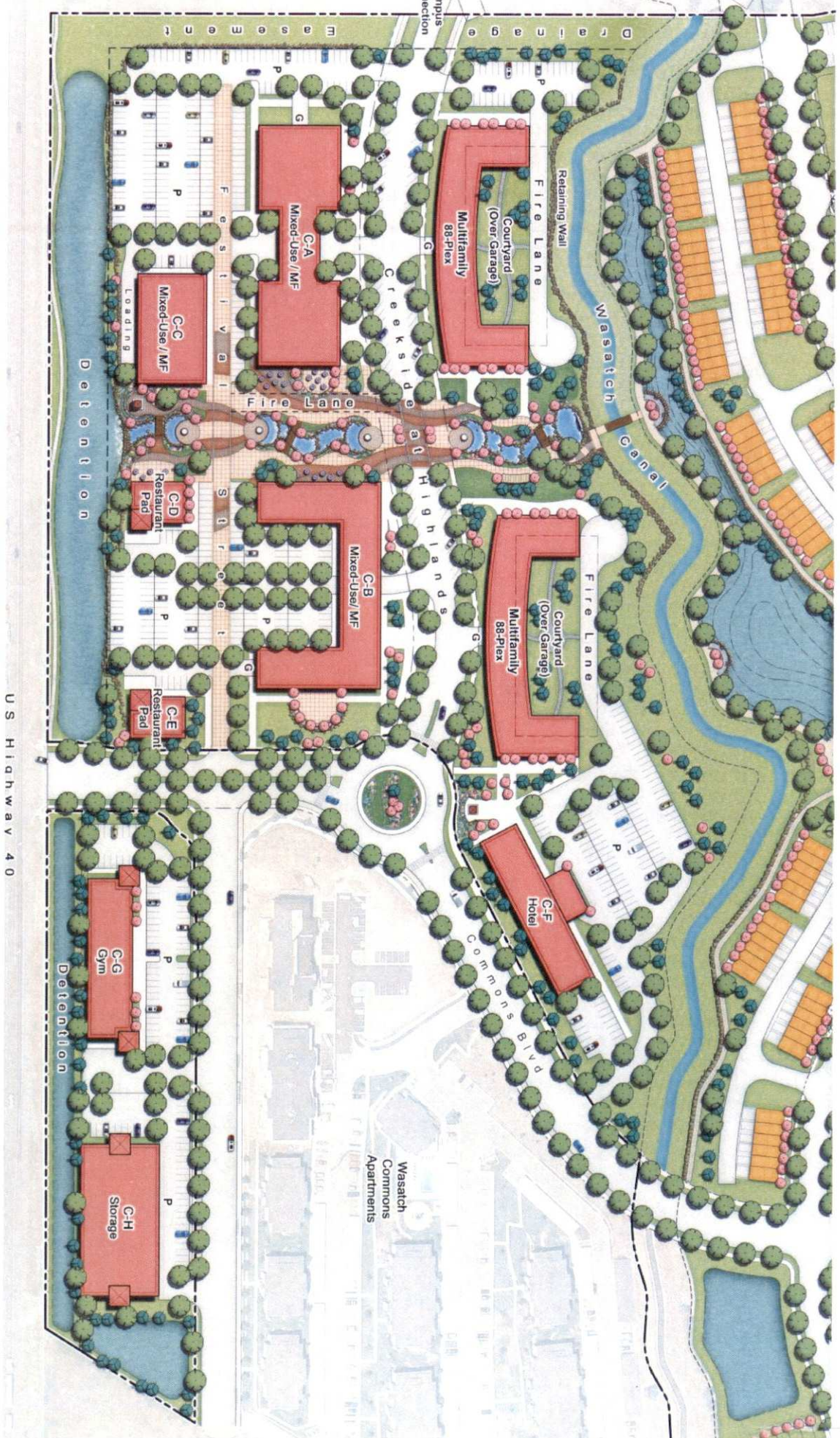

HIGHLANDS TOWN CENTER SECTION



100'
90'
80'
70'
60'
50'
40'
30'
20'
10'
0'

HIGHLANDS PEDESTRIAN PLAZAS

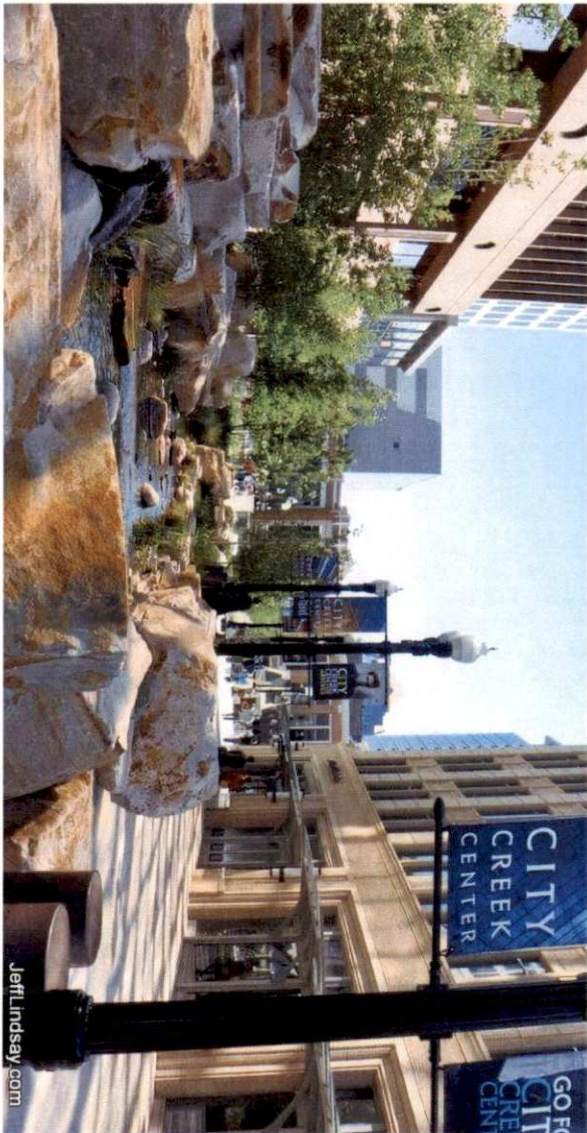

HIGHLANDS PARKS & SHELTERS

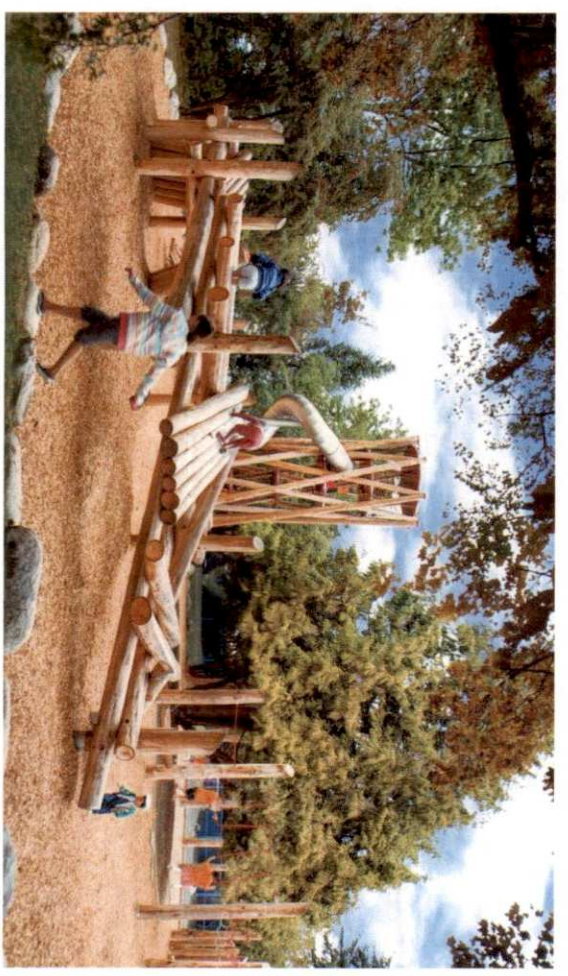
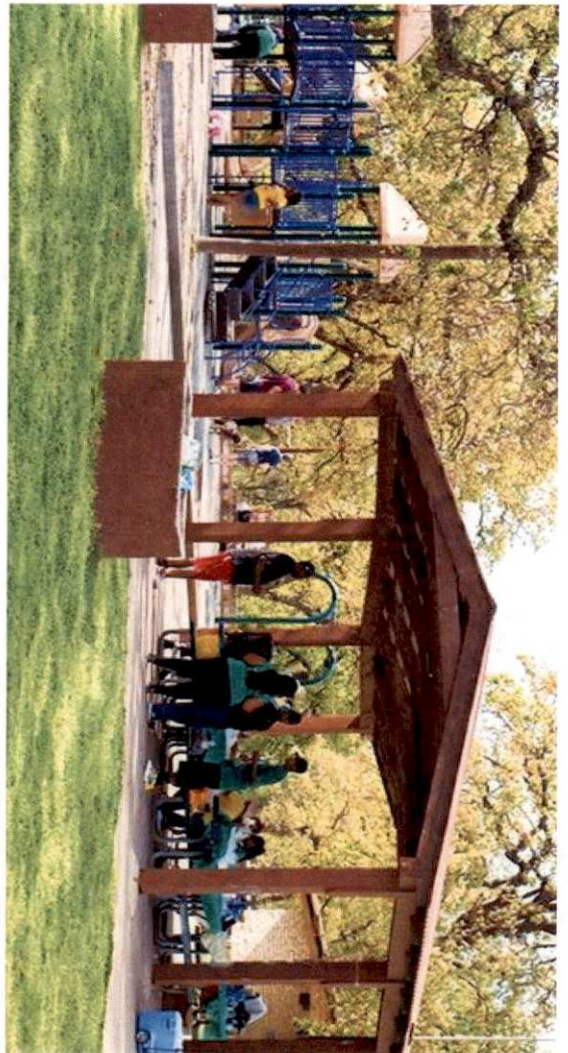
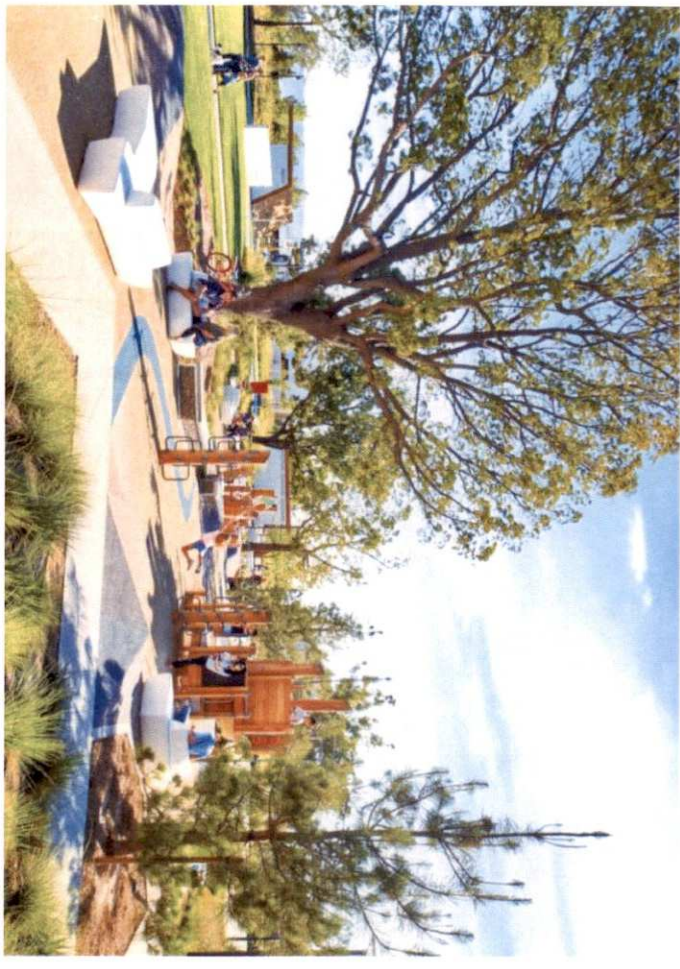

HIGHLANDS PARK FEATURES

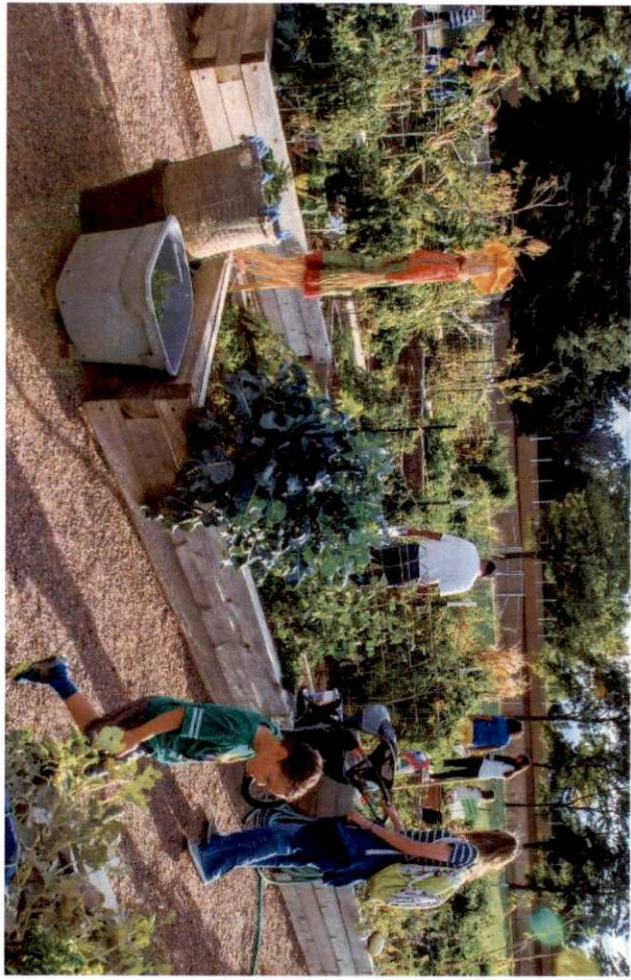

HIGHLANDS
PUBLIC ART

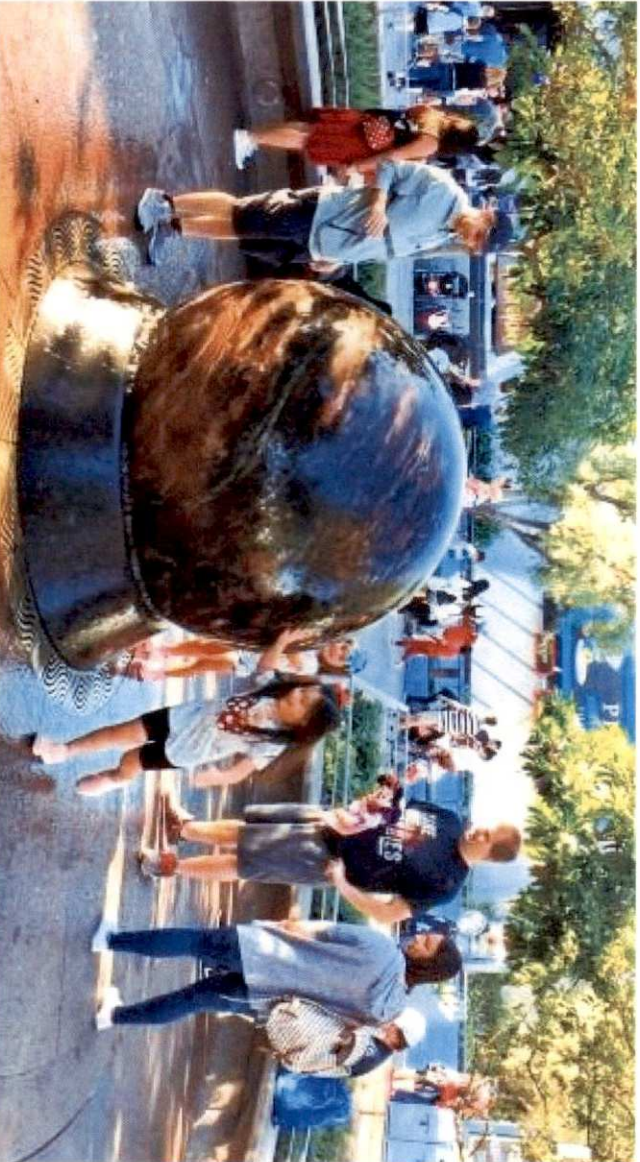

**HIGHLANDS
NATIVE LANDSCAPE PLANTINGS**

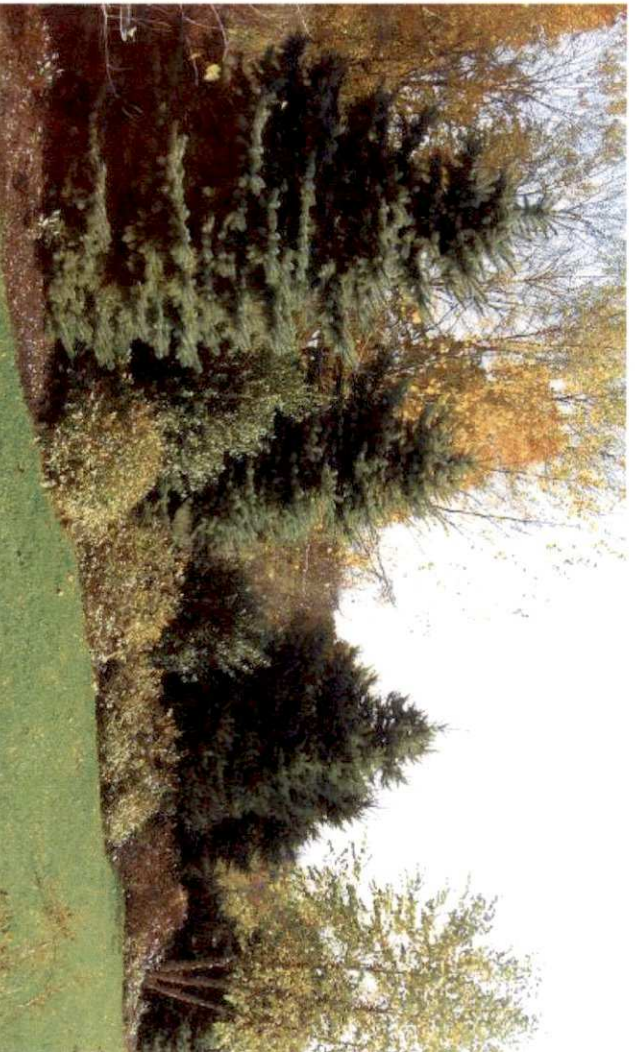
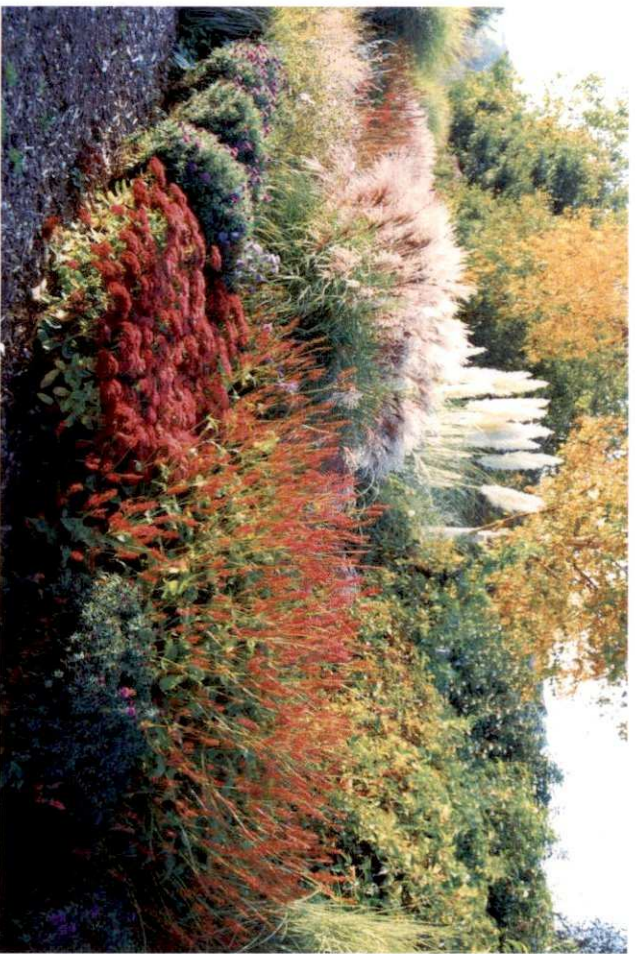
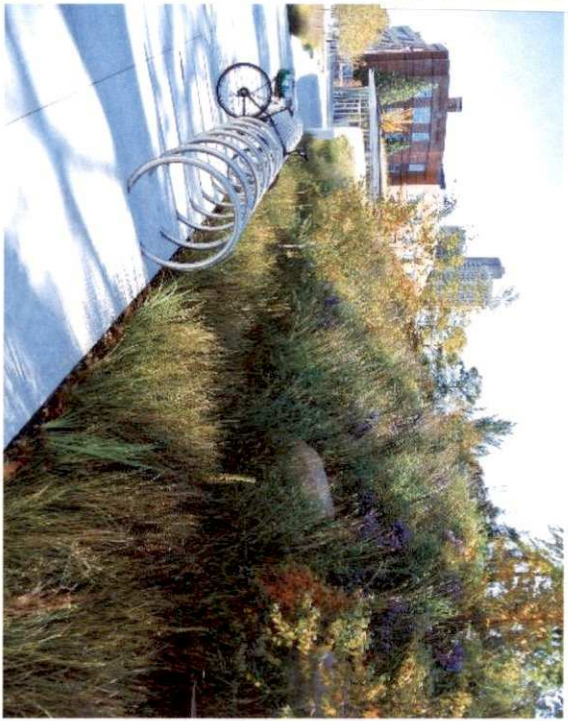

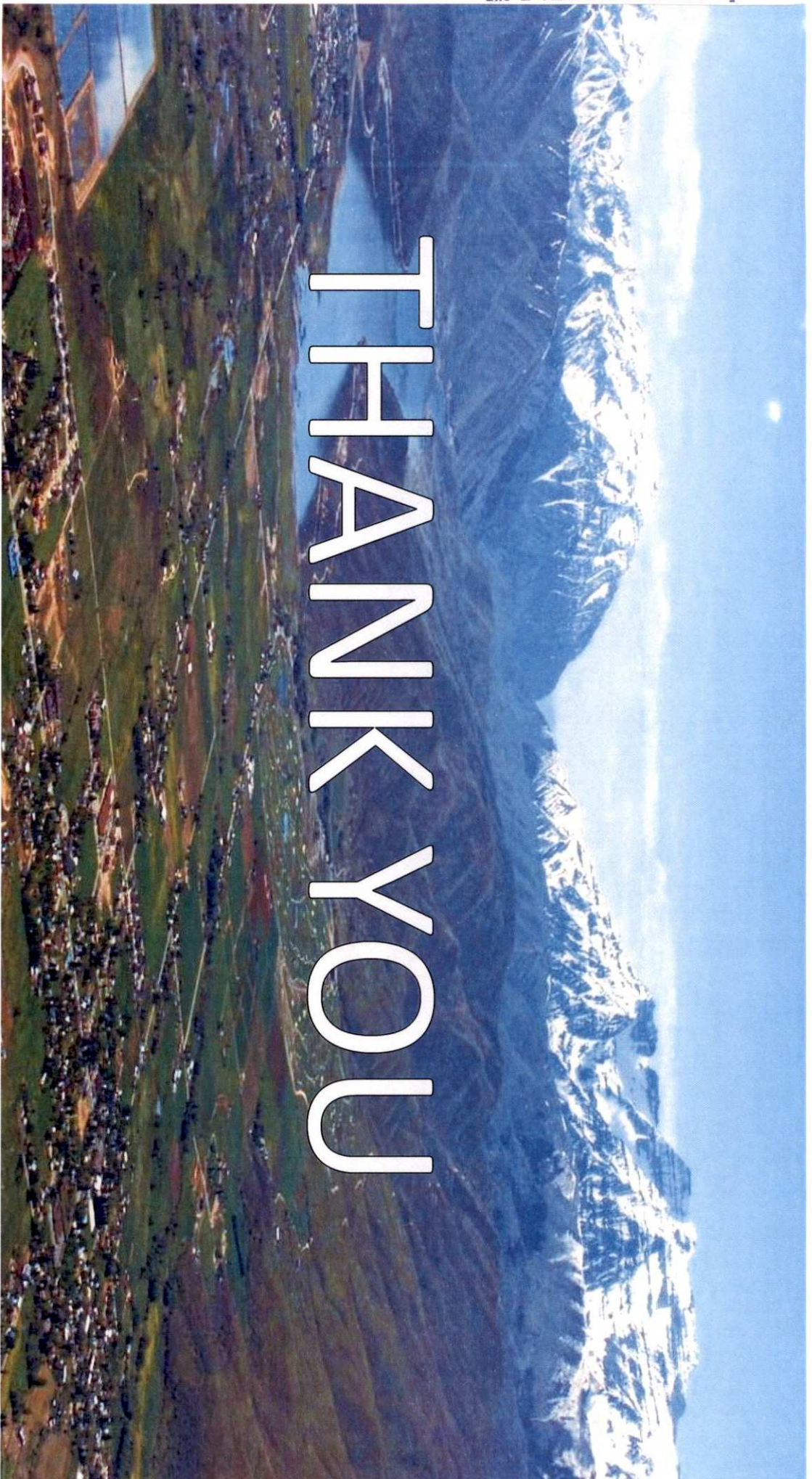

THANK YOU



88 Inverness Circle East Building J, Suite 101 - Englewood, CO 80012
T: 303.734.1777
E: info@LAIdesigngroup.com

- Architecture
- Planning & Entitlements
- Visual Media
- Landscape Architecture
- Real Estate Advisory

Exhibit P
to
Third Amendment
to
Development Agreement for Highlands Master Planned Community

Legal Description of Property on a Post-Adjustment Basis

HIGHLANDS RESIDENTIAL LEGAL DESCRIPTION:

A PARCEL OF LAND LOCATED IN SECTION 19, AND SECTION 20, TOWNSHIP 3 SOUTH, RANGE 5 EAST, SALT LAKE BASE AND MERIDIAN, WASATCH COUNTY, UTAH, BEING MORE PARTICULARLY DESCRIBED AS FOLLOWS:

BEGINNING AT THE INTERSECTION OF THE WEST LINE OF THE WASATCH CANAL, AND THE SOUTH PROPERTY LINE OF THE UTAH VALLEY STATE COLLEGE PROPERTY AS DESCRIBED PER ENTRY NO. 333087, SAID INTERSECTION BEING NORTH 00°29'50" WEST 118.62 FEET ALONG THE SECTION LINE AND EAST 427.42 FEET FROM THE WASATCH COUNTY SURVEY ALUMINUM PIPE CAP MONUMENT MARKING THE WEST QUARTER CORNER OF SECTION 20, TOWNSHIP 3 SOUTH, RANGE 5 EAST, SALT LAKE BASE AND MERIDIAN (BASIS OF BEARINGS FOR THIS DESCRIPTION IS SOUTH 04°04'03" EAST 2857.85 FEET ALONG A LINE DEFINED BY WASATCH COUNTY WATER SERVICE AREA NO. 1 SURVEY CONTROL MONUMENTS NO. 706 AND NO. 708 (BOTH ALUMINUM PIPE CAP MONUMENTS) SEE THE SURVEY CONTROL SHEET FOR THE CENTRAL UTAH WATER CONSERVANCY DISTRICT, WASATCH COUNTY WATER EFFICIENCY PROJECT, DRAWING NO. G-8 AS RECORDED IN BOOK 630 AT PAGES 766-767 AND AS ENTRY NO. 259146 OF THE WASATCH COUNTY RECORDS);

RUNNING THENCE ALONG SAID SOUTH PROPERTY LINE NORTH 58°00'22" EAST 202.21 FEET; THENCE NORTH 48°11'59" EAST 1098.03 FEET TO THE CENTERLINE OF THE TIMPANOGOS CANAL AS DESCRIBED IN THAT CONTRACT AND GRANT OF EASEMENT RECORDED AS ENTRY NO. 212641 OF SAID RECORDS; THENCE ALONG SAID CENTERLINE OF SAID CANAL THE FOLLOWING NINE COURSES: (1) NORTH 17°22'52" WEST 54.83 FEET; (2) NORTHWESTERLY 62.66 FEET ALONG A 57.21 FEET RADIUS CURVE TO THE LEFT THROUGH A CENTRAL ANGLE OF 62°45'14" AND A LONG CHORD OF NORTH 48°45'29" WEST 59.57 FEET; (3) NORTH 80°08'06" WEST 50.43 FEET; (4) NORTHWESTERLY 80.09 FEET ALONG A 77.16 FEET RADIUS CURVE TO THE RIGHT THROUGH A CENTRAL ANGLE OF 59°28'06" AND A LONG CHORD OF NORTH 50°24'03" WEST 76.54 FEET; (5) NORTH 20°40'00" WEST 67.54 FEET; (6) NORTH 20°40'00" WEST 39.32 FEET (7) NORTHWESTERLY 26.35 FEET ALONG A 73.32 FEET RADIUS CURVE TO THE LEFT THROUGH A CENTRAL ANGLE OF 20°35'35" AND A LONG CHORD OF NORTH 30°57'47" WEST 26.21 FEET; (8)

NORTH 41°15'35" WEST 114.29 FEET; (9) NORTHWESTERLY 11.22 FEET ALONG A 3029.45 FEET RADIUS CURVE TO THE LEFT THROUGH A CENTRAL ANGLE OF 0°12'44" AND A LONG CHORD OF NORTH 41°09'13" WEST 11.22 FEET TO A POINT ON THE EXTENSION THEREOF OF THE SOUTH PROPERTY LINE OF REINVESTMENT HOLDINGS PARCEL PER ENTRY NO. 371165; THENCE ALONG SOUTH PROPERTY LINE SOUTH 89°54'54" EAST 593.13 FEET; THENCE NORTH 21°24'08" EAST 258.16 FEET; THENCE SOUTH 70°03'55" EAST 252.30 FEET; THENCE SOUTH 26°05'49" EAST 172.53 FEET TO A POINT ON THE SOUTH PROPERTY LINE OF THE REINVESTMENT HOLDINGS PARCEL PER ENTRY NO. 371165; THENCE SOUTH 89°54'54" EAST 87.44 FEET TO A POINT ON THE SOUTHWESTERLY RIGHT OF WAY LINE OF A PROPOSED COLLECTOR ROAD;

THENCE ALONG THE SOUTHWESTERLY RIGHT OF WAY LINE OF PROPOSED COLLECTOR ROAD THE FOLLOWING FIVE (5) COURSES & DISTANCES:

(1) SOUTH 19°59'55" EAST 438.90 FEET TO A POINT OF CURVATURE;
 (2) SOUTHERLY 109.47 FEET ALONG THE ARC OF A 384.00 FOOT RADIUS CURVE TO THE LEFT; CHORD BEARS SOUTH 28°09'56" EAST 109.10 FEET;

(3) SOUTH 36°19'58" EAST 219.31 FEET TO A POINT OF CURVATURE;
 (4) SOUTHEASTERLY 96.86 FEET ALONG THE ARC OF A 384.00 FOOT RADIUS CURVE TO THE LEFT; CHORD BEARS SOUTH 43°33'32" EAST 96.60 FEET;

(5) SOUTH 50°47'07" EAST 679.45 FEET;
 THENCE SOUTH 39°12'53" WEST 160.00 FEET; THENCE SOUTH 48°47'41" WEST 209.84 FEET; THENCE SOUTH 47°21'15" WEST 58.64 FEET; THENCE SOUTH 11°49'56" EAST 40.21 FEET; THENCE SOUTH 49°46'59" WEST 126.86 FEET; THENCE SOUTH 59°43'42" WEST 112.86 FEET TO A POINT ON THE WEST PROPERTY LINE OF SAID REINVESTMENT HOLDINGS PARCEL PER ENTRY NO. 371165; THENCE ALONG SAID WEST PROPERTY LINE SOUTH 0°00'09" WEST 109.74 FEET TO THE CENTERLINE OF THE TIMPANOGOS CANAL AS DESCRIBED IN THAT CONTRACT AND GRANT OF EASEMENT RECORDED AS ENTRY NO. 212641 OF SAID RECORDS; THENCE ALONG SAID CENTERLINE THE FOLLOWING EIGHT COURSES:

(1) NORTH 10°34'34" WEST 26.14 FEET; (2) NORTHWESTERLY 18.66 FEET ALONG A 63.10 FEET RADIUS CURVE TO THE LEFT THROUGH A CENTRAL ANGLE OF 16°56'26" AND A LONG CHORD OF NORTH 19°02'47" WEST 18.59 FEET;

(3) NORTHWESTERLY 31.79 FEET ALONG A 63.10 FEET RADIUS CURVE TO THE LEFT THROUGH A CENTRAL ANGLE OF 28°51'57" AND A LONG CHORD OF NORTH 41°56'59" WEST 31.45 FEET;

(4) NORTH 56°22'57" WEST 51.03 FEET; (5) NORTHWESTERLY 56.42 FEET ALONG A 130.89 FEET RADIUS CURVE TO THE RIGHT THROUGH A CENTRAL ANGLE OF 24°41'49" AND A LONG CHORD OF NORTH 44°02'02" WEST 55.98 FEET; (6) NORTH 31°41'08" WEST 60.09 FEET; (7) NORTHWESTERLY 126.00 FEET ALONG A 664.07 FEET RADIUS CURVE TO THE LEFT THROUGH A CENTRAL ANGLE OF 10°52'18" AND A LONG CHORD OF NORTH 37°07'17" WEST 125.82

FEET; (8) NORTH 42°33'26" WEST 8.76 FEET TO THE NORTH PROPERTY LINE OF THE VIEWPOINT HOLDINGS, LLC, PARCEL 1, PER ENTRY NO. 490647; THENCE ALONG SAID NORTH PROPERTY LINE NORTH 89°59'12" WEST 303.12 FEET TO THE NORTHWEST PROPERTY CORNER OF SAID VIEWPOINT HOLDINGS, LLC PARCEL; THENCE ALONG THE WEST PROPERTY LINE SOUTH 0°00'48" WEST 425.00 FEET, THENCE SOUTH 0°32'12" EAST 134.12 FEET TO THE SOUTHWEST PROPERTY CORNER OF THE VIEWPOINT HOLDINGS, LLC, PARCEL 2, PER ENTRY NO. 490647; THENCE ALONG THE SOUTH PROPERTY LINE NORTH 89°49'38" EAST 528.67 FEET TO A POINT ON THE WEST PROPERTY LINE OF THE REINVESTMENT HOLDINGS PARCEL PER ENTRY NO. 371165; THENCE SOUTH 0°00'09" WEST 1263.25 FEET TO THE NORTH PROPERTY LINE OF TRUDY F BISEL PARCEL PER ENTRY NO. 442517; THENCE ALONG SAID NORTH PROPERTY LINE NORTH 89°59'12" WEST 676.35 FEET TO THE CENTERLINE OF THE WASATCH CANAL; THENCE NORTH 89°59'12" WEST 52.77 FEET TO A POINT ON THE WEST LINE OF WASATCH CANAL AS DESCRIBED IN THAT CONTRACT AND GRANT OF EASEMENT RECORDED AS ENTRY NO. 212641 OF SAID RECORDS; THENCE ALONG SAID WEST LINE OF THE WASATCH CANAL THE FOLLOWING FIFTY-TWO COURSES:

(1) NORTHWESTERLY 36.10 FEET ALONG A 180.84 FEET RADIUS CURVE TO THE RIGHT THROUGH A CENTRAL ANGLE OF 11°26'10" AND A LONG CHORD OF NORTH 48°19'44" WEST 36.04 FEET; (2) NORTH 42°36'39" WEST 243.31 FEET; (3) NORTHWESTERLY 59.37 FEET ALONG A 244.36 FEET RADIUS CURVE TO THE LEFT THROUGH A CENTRAL ANGLE OF 13°55'16" AND A LONG CHORD OF NORTH 49°34'17" WEST 59.23 FEET; (4) NORTH 56°31'55" WEST 141.96 FEET; (5) NORTHWESTERLY 52.18 FEET ALONG A 139.48 FEET RADIUS CURVE TO THE RIGHT THROUGH A CENTRAL ANGLE OF 21°26'10" AND A LONG CHORD OF NORTH 45°48'50" WEST 51.88 FEET; (6) NORTH 35°05'45" WEST 32.66 FEET; (7) NORTHWESTERLY 24.90 FEET ALONG A 52.16 FEET RADIUS CURVE TO THE LEFT THROUGH A CENTRAL ANGLE OF 27°21'17" AND A LONG CHORD OF NORTH 48°46'23" WEST 24.67 FEET; (8) NORTH 62°27'02" WEST 31.01 FEET; (9) NORTHWESTERLY 60.61 FEET ALONG A 71.10 FEET RADIUS CURVE TO THE RIGHT THROUGH A CENTRAL ANGLE OF 48°50'40" AND A LONG CHORD OF NORTH 45°21'15" WEST 58.80 FEET; (10) NORTH 28°15'28" WEST 46.48 FEET; (11) NORTHWESTERLY 27.92 FEET ALONG A 75.00 FEET RADIUS CURVE TO THE LEFT THROUGH A CENTRAL ANGLE OF 21°19'55" AND A LONG CHORD OF NORTH 38°55'26" WEST 27.76 FEET; (12) NORTH 49°35'23" WEST 30.70 FEET; (13) NORTHWESTERLY 89.92 FEET ALONG A 200.95 FEET RADIUS CURVE TO THE RIGHT THROUGH A CENTRAL ANGLE OF 25°38'22" AND A LONG CHORD OF NORTH 36°46'12" WEST 89.18 FEET; (14) NORTH 23°57'01" WEST 161.09 FEET; (15) NORTHERLY 56.02 FEET ALONG A 129.03 FEET RADIUS CURVE TO THE RIGHT THROUGH A CENTRAL ANGLE OF 24°52'29" AND A LONG CHORD OF NORTH 11°30'47" WEST 55.58 FEET; (16) NORTH 0°55'28" EAST 27.79 FEET; (17) NORTHWESTERLY 13.67 FEET ALONG A 19.04 FEET RADIUS CURVE TO THE LEFT THROUGH A CENTRAL ANGLE OF 41°08'53" AND A LONG CHORD OF NORTH 19°38'58" WEST 13.38 FEET; (18) NORTH 40°13'25" WEST 94.27 FEET; (19) NORTHERLY 88.73 FEET ALONG A 107.33 FEET RADIUS CURVE TO THE RIGHT

THROUGH A CENTRAL ANGLE OF 47°22'02" AND A LONG CHORD OF NORTH 16°32'24" WEST 86.23 FEET; (20) NORTH 7°08'37" EAST 78.23 FEET; (21) NORTHERLY 25.17 FEET ALONG A 99.68 FEET RADIUS CURVE TO THE LEFT THROUGH A CENTRAL ANGLE OF 14°27'55" AND A LONG CHORD OF NORTH 0°05'21" WEST 25.10 FEET; (22) NORTH 7°19'18" WEST 115.57 FEET; (23) NORTHWESTERLY 22.33 FEET ALONG A 12.44 FEET RADIUS CURVE TO THE LEFT THROUGH A CENTRAL ANGLE OF 102°52'01" AND A LONG CHORD OF NORTH 58°45'19" WEST 19.45 FEET; (24) SOUTH 69°48'41" WEST 41.25 FEET; (25) NORTHWESTERLY 126.93 FEET ALONG A 109.54 FEET RADIUS CURVE TO THE RIGHT THROUGH A CENTRAL ANGLE OF 66°23'22" AND A LONG CHORD OF NORTH 76°59'38" WEST 119.94 FEET; (26) NORTH 43°47'57" WEST 25.44 FEET; (27) NORTHWESTERLY 32.56 FEET ALONG A 99.98 FEET RADIUS CURVE TO THE LEFT THROUGH A CENTRAL ANGLE OF 18°39'30" AND A LONG CHORD OF NORTH 53°07'42" WEST 32.41 FEET; (28) NORTHWESTERLY 45.58 FEET ALONG A 162.73 FEET RADIUS CURVE TO THE RIGHT THROUGH A CENTRAL ANGLE OF 16°02'54" AND A LONG CHORD OF NORTH 54°26'00" WEST 45.43 FEET; (29) NORTH 46°24'33" WEST 16.21 FEET; (30) NORTHERLY 91.08 FEET ALONG A 98.34 FEET RADIUS CURVE TO THE RIGHT THROUGH A CENTRAL ANGLE OF 53°04'03" AND A LONG CHORD OF NORTH 19°52'32" WEST 87.86 FEET; (31) NORTH 6°39'30" EAST 49.88 FEET; (32) NORTHWESTERLY 4.32 FEET ALONG A 3.28 FEET RADIUS CURVE TO THE LEFT THROUGH A CENTRAL ANGLE OF 75°25'34" AND A LONG CHORD OF NORTH 31°03'17" WEST 4.01 FEET; (33) NORTH 68°46'04" WEST 27.75 FEET; (34) NORTHWESTERLY 50.30 FEET ALONG A 340.23 FEET RADIUS CURVE TO THE LEFT THROUGH A CENTRAL ANGLE OF 8°28'12" AND A LONG CHORD OF NORTH 73°00'10" WEST 50.25 FEET; (35) NORTH 77°14'16" WEST 41.08 FEET; (36) NORTHWESTERLY 51.44 FEET ALONG A 124.93 FEET RADIUS CURVE TO THE RIGHT THROUGH A CENTRAL ANGLE OF 23°35'29" AND A LONG CHORD OF NORTH 65°26'31" WEST 51.08 FEET; (37) NORTH 53°38'47" WEST 38.81 FEET; (38) NORTHWESTERLY 61.02 FEET ALONG A 138.65 FEET RADIUS CURVE TO THE RIGHT THROUGH A CENTRAL ANGLE OF 25°12'50" AND A LONG CHORD OF NORTH 41°02'22" WEST 60.52 FEET; (39) NORTH 28°25'57" WEST 39.08 FEET; (40) NORTHWESTERLY 43.52 FEET ALONG A 64.31 FEET RADIUS CURVE TO THE LEFT THROUGH A CENTRAL ANGLE OF 38°46'17" AND A LONG CHORD OF NORTH 47°49'05" WEST 42.69 FEET; (41) NORTH 67°12'14" WEST 30.51 FEET; (42) NORTHWESTERLY 99.61 FEET ALONG A 133.72 FEET RADIUS CURVE TO THE RIGHT THROUGH A CENTRAL ANGLE OF 42°40'53" AND A LONG CHORD OF NORTH 45°51'47" WEST 97.32 FEET; (43) NORTH 24°31'21" WEST 30.12 FEET; (44) NORTHWESTERLY 61.74 FEET ALONG A 273.10 FEET RADIUS CURVE TO THE LEFT THROUGH A CENTRAL ANGLE OF 12°57'12" AND A LONG CHORD OF NORTH 30°59'57" WEST 61.61 FEET; (45) NORTH 37°28'33" WEST 20.28 FEET; (46) NORTHERLY 79.97 FEET ALONG A 65.40 FEET RADIUS CURVE TO THE RIGHT THROUGH A CENTRAL ANGLE OF 70°03'24" AND A LONG CHORD OF NORTH 2°26'51" WEST 75.08 FEET; (47) NORTH 32°34'51" EAST 61.85 FEET; (48) NORTHERLY 4.17 FEET ALONG A 4.35 FEET RADIUS CURVE TO THE LEFT THROUGH A CENTRAL ANGLE OF 54°54'55" AND A LONG CHORD OF NORTH 5°07'24" EAST 4.01 FEET; (49) NORTH 22°20'04" WEST 44.62 FEET; (50)

NORTHERLY 41.59 FEET ALONG A 59.20 FEET RADIUS CURVE TO THE RIGHT THROUGH A CENTRAL ANGLE OF 40°14'52" AND A LONG CHORD OF NORTH 2°12'38" WEST 40.74 FEET; (51) NORTH 17°54'48" EAST 63.72 FEET; (52) NORTHERLY 6.30 FEET ALONG A 12.00 FEET RADIUS CURVE TO THE LEFT THROUGH A CENTRAL ANGLE OF 30°03'44" AND A LONG CHORD OF NORTH 2°52'56" EAST 6.22 FEET TO THE POINT OF BEGINNING.

CONTAINING 116.26 ACRES.

COMMERCIAL PARCELS:

NORTH PARCEL:

BEGINNING AT THE INTERSECTION OF THE NORTHERLY RIGHT-OF-WAY LINE OF COMMONS BOULEVARD AND THE EASTERLY RIGHT-OF-WAY LINE OF STATE HIGHWAY 40, SAID POINT ALSO BEING NORTH 00°06'58" WEST 1,407.18 FEET ALONG THE SECTION LINE AND EAST 212.70 FEET FROM THE SOUTHWEST CORNER OF SECTION 20, TOWNSHIP 3 SOUTH, RANGE 5 EAST, SALT LAKE BASE AND MERIDIAN; AND RUNNING THENCE NORTH 32°00'26" WEST 1,057.02 FEET ALONG THE EASTERLY RIGHT-OF-WAY LINE OF SAID STATE HIGHWAY 40; THENCE NORTH 57°59'34" EAST 909.98 FEET TO THE WESTERLY LINE OF THE WASATCH CANAL; THENCE SOUTHEASTERLY 13.50 FEET ALONG THE ARC OF A 12.00 FOOT RADIUS CURVE TO THE RIGHT (CENTER BEARS SOUTH 43°16'46" WEST AND THE CHORD BEARS SOUTH 14°28'51" EAST 12.80 FEET WITH A CENTRAL ANGLE OF 64°28'45") ALONG THE WESTERLY LINE OF THE WASATCH CANAL; THENCE SOUTH 17°45'17" WEST 63.72 FEET ALONG THE WESTERLY LINE OF THE WASATCH CANAL; THENCE SOUTHEASTERLY 41.60 FEET ALONG THE ARC OF A 59.20 FOOT RADIUS CURVE TO THE LEFT (CENTER BEARS SOUTH 72°14'43" EAST AND THE CHORD BEARS SOUTH 02°22'27" EAST 40.75 FEET WITH A CENTRAL ANGLE OF 40°15'28") ALONG THE WESTERLY LINE OF THE WASATCH CANAL; THENCE SOUTH 22°29'35" EAST 44.62 FEET ALONG THE WESTERLY LINE OF THE WASATCH CANAL; THENCE SOUTHWESTERLY 4.17 FEET ALONG THE ARC OF A 4.35 FOOT RADIUS CURVE TO THE RIGHT (CENTER BEARS SOUTH 67°30'25" WEST AND THE CHORD BEARS SOUTH 04°57'50" WEST 4.01 FEET WITH A CENTRAL ANGLE OF 54°54'51") ALONG THE WESTERLY LINE OF THE WASATCH CANAL; THENCE SOUTH 32°25'20" WEST 61.85 FEET ALONG THE WESTERLY LINE OF THE WASATCH CANAL; THENCE SOUTHEASTERLY 79.97 FEET ALONG THE ARC OF A 65.40 FOOT RADIUS CURVE TO THE LEFT (CENTER BEARS SOUTH 57°34'40" EAST AND THE CHORD BEARS SOUTH 02°36'27" EAST 75.08 FEET WITH A CENTRAL ANGLE OF 70°03'35") ALONG THE WESTERLY LINE OF THE WASATCH CANAL; THENCE SOUTH 37°38'04" EAST 20.28 FEET ALONG THE WESTERLY LINE OF THE WASATCH CANAL; THENCE SOUTHEASTERLY 61.74 FEET ALONG THE ARC OF A 273.10 FOOT RADIUS CURVE TO THE RIGHT (CENTER BEARS SOUTH 52°21'56" WEST AND THE CHORD BEARS SOUTH 31°09'29" EAST 61.61 FEET WITH A CENTRAL ANGLE OF 12°57'09") ALONG THE WESTERLY LINE OF THE WASATCH CANAL; THENCE SOUTH 24°40'52" EAST 30.12 FEET ALONG THE WESTERLY LINE

OF THE WASATCH CANAL; THENCE SOUTHEASTERLY 99.61 FEET ALONG THE ARC OF A 133.72 FOOT RADIUS CURVE TO THE LEFT (CENTER BEARS NORTH 65°19'08" EAST AND THE CHORD BEARS SOUTH 46°01'20" EAST 97.33 FEET WITH A CENTRAL ANGLE OF 42°40'55") ALONG THE WESTERLY LINE OF THE WASATCH CANAL; THENCE SOUTH 67°21'45" EAST 30.51 FEET ALONG THE WESTERLY LINE OF THE WASATCH CANAL; THENCE SOUTHEASTERLY 43.52 FEET ALONG THE ARC OF A 64.31 FOOT RADIUS CURVE TO THE RIGHT (CENTER BEARS SOUTH 22°38'15" WEST AND THE CHORD BEARS SOUTH 47°58'31" EAST 42.70 FEET WITH A CENTRAL ANGLE OF 38°46'28") ALONG THE WESTERLY LINE OF THE WASATCH CANAL; THENCE SOUTH 28°35'28" EAST 39.08 FEET ALONG THE WESTERLY LINE OF THE WASATCH CANAL; THENCE SOUTHEASTERLY 61.02 FEET ALONG THE ARC OF A 138.66 FOOT RADIUS CURVE TO THE LEFT (CENTER BEARS NORTH 61°24'32" EAST AND THE CHORD BEARS SOUTH 41°11'55" EAST 60.53 FEET WITH A CENTRAL ANGLE OF 25°12'54") ALONG THE WESTERLY LINE OF THE WASATCH CANAL; THENCE SOUTH 53°48'18" EAST 38.81 FEET ALONG THE WESTERLY LINE OF THE WASATCH CANAL; THENCE SOUTHEASTERLY 51.43 FEET ALONG THE ARC OF A 124.93 FOOT RADIUS CURVE TO THE LEFT (CENTER BEARS NORTH 36°11'42" EAST AND THE CHORD BEARS SOUTH 65°35'56" EAST 51.07 FEET WITH A CENTRAL ANGLE OF 23°35'17") ALONG THE WESTERLY LINE OF THE WASATCH CANAL; THENCE SOUTH 77°23'47" EAST 41.08 FEET ALONG THE WESTERLY LINE OF THE WASATCH CANAL; THENCE SOUTHEASTERLY 50.29 FEET ALONG THE ARC OF A 340.23 FOOT RADIUS CURVE TO THE RIGHT (CENTER BEARS SOUTH 12°36'13" WEST AND THE CHORD BEARS SOUTH 73°09'41" EAST 50.25 FEET WITH A CENTRAL ANGLE OF 08°28'11") ALONG THE WESTERLY LINE OF THE WASATCH CANAL; THENCE SOUTH 68°55'35" EAST 27.75 FEET ALONG THE WESTERLY LINE OF THE WASATCH CANAL; THENCE SOUTHEASTERLY 4.32 FEET ALONG THE ARC OF A 3.28 FOOT RADIUS CURVE TO THE RIGHT (CENTER BEARS SOUTH 21°04'25" WEST AND THE CHORD BEARS SOUTH 31°12'43" EAST 4.01 FEET WITH A CENTRAL ANGLE OF 75°25'43") ALONG THE WESTERLY LINE OF THE WASATCH CANAL; THENCE SOUTH 06°29'59" WEST 49.88 FEET ALONG THE WESTERLY LINE OF THE WASATCH CANAL; THENCE SOUTHEASTERLY 91.09 FEET ALONG THE ARC OF A 98.34 FOOT RADIUS CURVE TO THE LEFT (CENTER BEARS SOUTH 83°30'01" EAST AND THE CHORD BEARS SOUTH 20°02'06" EAST 87.86 FEET WITH A CENTRAL ANGLE OF 53°04'09") ALONG THE WESTERLY LINE OF THE WASATCH CANAL; THENCE SOUTH 46°34'04" EAST 16.21 FEET ALONG THE WESTERLY LINE OF THE WASATCH CANAL; THENCE SOUTHEASTERLY 45.58 FEET ALONG THE ARC OF A 162.73 FOOT RADIUS CURVE TO THE LEFT (CENTER BEARS NORTH 43°25'56" EAST AND THE CHORD BEARS SOUTH 54°35'33" EAST 45.43 FEET WITH A CENTRAL ANGLE OF 16°02'58") ALONG THE WESTERLY LINE OF THE WASATCH CANAL; THENCE SOUTHEASTERLY 32.56 FEET ALONG THE ARC OF A 99.98 FOOT RADIUS CURVE TO THE RIGHT (CENTER BEARS SOUTH 27°22'58" WEST AND THE CHORD BEARS SOUTH 53°17'16" EAST 32.42 FEET WITH A CENTRAL ANGLE OF 18°39'31") ALONG THE WESTERLY LINE OF THE WASATCH CANAL; THENCE SOUTH 43°57'28" EAST 25.44 FEET ALONG THE WESTERLY LINE OF THE WASATCH CANAL; THENCE SOUTHEASTERLY 126.92 FEET ALONG THE ARC OF A 109.54 FOOT RADIUS CURVE TO THE LEFT (CENTER BEARS NORTH 46°02'32"

EAST AND THE CHORD BEARS SOUTH 77°09'00" EAST 119.93 FEET WITH A CENTRAL ANGLE OF 66°23'03") ALONG THE WESTERLY LINE OF THE WASATCH CANAL; THENCE NORTH 69°39'10" EAST 41.25 FEET ALONG THE WESTERLY LINE OF THE WASATCH CANAL; THENCE SOUTHEASTERLY 22.33 FEET ALONG THE ARC OF A 12.44 FOOT RADIUS CURVE TO THE RIGHT (CENTER BEARS SOUTH 20°20'50" EAST AND THE CHORD BEARS SOUTH 58°54'45" EAST 19.45 FEET WITH A CENTRAL ANGLE OF 102°52'09") ALONG THE WESTERLY LINE OF THE WASATCH CANAL; THENCE SOUTH 07°28'49" EAST 115.57 FEET ALONG THE WESTERLY LINE OF THE WASATCH CANAL; THENCE SOUTHEASTERLY 25.17 FEET ALONG THE ARC OF A 99.68 FOOT RADIUS CURVE TO THE RIGHT (CENTER BEARS SOUTH 82°31'11" WEST AND THE CHORD BEARS SOUTH 00°14'49" EAST 25.10 FEET WITH A CENTRAL ANGLE OF 14°27'59") ALONG THE WESTERLY LINE OF THE WASATCH CANAL; THENCE SOUTH 06°59'06" WEST 78.23 FEET ALONG THE WESTERLY LINE OF THE WASATCH CANAL; THENCE SOUTHEASTERLY 88.74 FEET ALONG THE ARC OF A 107.33 FOOT RADIUS CURVE TO THE LEFT (CENTER BEARS SOUTH 83°00'54" EAST AND THE CHORD BEARS SOUTH 16°42'03" EAST 86.23 FEET WITH A CENTRAL ANGLE OF 47°22'19") ALONG THE WESTERLY LINE OF THE WASATCH CANAL; THENCE SOUTH 40°22'56" EAST 94.27 FEET ALONG THE WESTERLY LINE OF THE WASATCH CANAL; THENCE SOUTHEASTERLY 13.67 FEET ALONG THE ARC OF A 19.04 FOOT RADIUS CURVE TO THE RIGHT (CENTER BEARS SOUTH 49°37'04" WEST AND THE CHORD BEARS SOUTH 19°48'25" EAST 13.38 FEET WITH A CENTRAL ANGLE OF 41°09'02") ALONG THE WESTERLY LINE OF THE WASATCH CANAL; THENCE SOUTH 00°45'57" WEST 27.79 FEET ALONG THE WESTERLY LINE OF THE WASATCH CANAL; THENCE SOUTHEASTERLY 56.01 FEET ALONG THE ARC OF A 129.03 FOOT RADIUS CURVE TO THE LEFT (CENTER BEARS SOUTH 89°14'03" EAST AND THE CHORD SOUTH 11 °40'13" EAST 55.57 FEET WITH A CENTRAL ANGLE OF 24°52'21") ALONG THE WESTERLY LINE OF THE WASATCH CANAL; THENCE SOUTH 24°06'32" EAST 157.61 FEET ALONG THE WESTERLY LINE OF THE WASATCH CANAL TO THE SOUTHERLY RIGHT-OF-WAY LINE OF COMMONS BOULEVARD; THENCE NORTHWESTERLY 259.90 FEET ALONG THE ARC OF A 483.50 FOOT RADIUS CURVE TO THE RIGHT (CENTER BEARS NORTH 00°53'23" WEST AND THE CHORD BEARS NORTH 75°29'26" WEST 256.78 FEET WITH A CENTRAL ANGLE OF 30°47'55") ALONG THE SOUTHERLY RIGHT-OF-WAY LINE OF COMMONS BOULEVARD; THENCE NORTH 60°05'28" WEST 29.46 FEET ALONG THE SOUTHERLY RIGHT-OF-WAY LINE OF COMMONS BOULEVARD; THENCE NORTH 29°54'32" EAST 67.00 FEET TO THE NORTHERLY RIGHT-OF-WAY LINE OF COMMONS BOULEVARD; THENCE NORTH 60°05'28" WEST 50.00 FEET ALONG SAID NORTHERLY RIGHT-OF-WAY LINE OF COMMONS BOULEVARD; THENCE NORTHWESTERLY 13.57 FEET ALONG THE ARC OF A 17.50 FOOT RADIUS CURVE TO THE RIGHT (CENTER BEARS NORTH 29°54'32" EAST AND THE CHORD BEARS NORTH 37°53'00" WEST 13.23 FEET WITH A CENTRAL ANGLE OF 44°24'55") ALONG SAID NORTHERLY RIGHT-OF-WAY LINE OF COMMONS BOULEVARD; THENCE NORTH 60°05'28" WEST 103.22 FEET ALONG SAID NORTHERLY RIGHT-OF-WAY LINE OF COMMONS BOULEVARD; THENCE NORTHWESTERLY 391.17 FEET ALONG THE ARC OF A 488.50 FOOT RADIUS CURVE TO THE LEFT (CENTER BEARS SOUTH 29°54'32" WEST AND THE CHORD

BEARS NORTH $83^{\circ}01'52''$ WEST 380.80 FEET WITH A CENTRAL ANGLE OF $45^{\circ}52'49''$) ALONG SAID NORTHERLY RIGHT-OF-WAY LINE OF COMMONS BOULEVARD; THENCE NORTHWESTERLY 30.50 FEET ALONG THE ARC OF A 35.50 FOOT RADIUS CURVE TO THE RIGHT (CENTER BEARS NORTH $15^{\circ}58'17''$ WEST AND THE CHORD BEARS NORTH $81^{\circ}21'31''$ WEST 29.57 FEET WITH A CENTRAL ANGLE OF $49^{\circ}13'32''$) ALONG SAID NORTHERLY RIGHT-OF-WAY LINE OF COMMONS BOULEVARD; THENCE NORTHWESTERLY 50.41 FEET ALONG THE ARC OF A 94.50 FOOT RADIUS CURVE TO THE LEFT (CENTER BEARS SOUTH $33^{\circ}15'16''$ WEST AND THE CHORD BEARS NORTH $72^{\circ}01'41''$ WEST 49.82 FEET WITH A CENTRAL ANGLE OF $30^{\circ}33'53''$) ALONG SAID NORTHERLY RIGHT-OF-WAY LINE OF COMMONS BOULEVARD; THENCE NORTHWESTERLY 34.27 FEET ALONG THE ARC OF A 35.50 FOOT RADIUS CURVE TO THE RIGHT (CENTER BEARS NORTH $02^{\circ}41'22''$ EAST AND THE CHORD BEARS NORTH $59^{\circ}39'32''$ WEST 32.95 FEET WITH A CENTRAL ANGLE OF $55^{\circ}18'12''$) ALONG SAID NORTHERLY RIGHT-OF-WAY LINE OF COMMONS BOULEVARD; THENCE NORTH $32^{\circ}00'26''$ WEST 11.87 FEET ALONG SAID NORTHERLY RIGHT-OF-WAY LINE OF COMMONS BOULEVARD; THENCE SOUTH $50^{\circ}09'54''$ WEST 77.72 FEET ALONG SAID NORTHERLY RIGHT-OF-WAY LINE OF COMMONS BOULEVARD; THENCE SOUTH $32^{\circ}00'26''$ EAST 1.29 FEET ALONG SAID NORTHERLY RIGHT-OF-WAY LINE OF COMMONS BOULEVARD; THENCE SOUTHEASTERLY 34.27 FEET ALONG THE ARC OF A 35.50 FOOT RADIUS CURVE TO THE RIGHT (CENTER BEARS SOUTH $57^{\circ}59'34''$ WEST AND THE CHORD BEARS SOUTH $04^{\circ}21'20''$ EAST 32.95 FEET WITH A CENTRAL ANGLE OF $55^{\circ}18'12''$) ALONG SAID NORTHERLY RIGHT-OF-WAY LINE OF COMMONS BOULEVARD; THENCE SOUTHWESTERLY 26.91 FEET ALONG THE ARC OF A 94.50 FOOT RADIUS CURVE TO THE LEFT (CENTER BEARS SOUTH $66^{\circ}42'14''$ EAST AND THE CHORD BEARS SOUTH $15^{\circ}08'20''$ WEST 26.82 FEET WITH A CENTRAL ANGLE OF $16^{\circ}18'53''$) ALONG SAID NORTHERLY RIGHT-OF-WAY LINE OF COMMONS BOULEVARD; THENCE SOUTHWESTERLY 31.61 FEET ALONG THE ARC OF A 35.50 FOOT RADIUS CURVE TO THE RIGHT (CENTER BEARS NORTH $83^{\circ}01'07''$ WEST AND THE CHORD BEARS SOUTH $32^{\circ}29'14''$ WEST 30.57 FEET WITH A CENTRAL ANGLE OF $51^{\circ}00'41''$) ALONG SAID NORTHERLY RIGHT-OF-WAY LINE OF COMMONS BOULEVARD; THENCE SOUTH $57^{\circ}59'34''$ WEST 24.11 FEET; THENCE SOUTHWESTERLY 21.44 FEET ALONG THE ARC OF A 135.00 FOOT RADIUS CURVE TO THE RIGHT (CENTER BEARS NORTH $32^{\circ}00'26''$ WEST AND THE CHORD BEARS SOUTH $62^{\circ}32'31''$ WEST 21.42 FEET WITH A CENTRAL ANGLE OF $09^{\circ}05'55''$) ALONG SAID NORTHERLY RIGHT-OF-WAY LINE OF COMMONS BOULEVARD; THENCE SOUTH $67^{\circ}05'29''$ WEST 52.01 FEET ALONG SAID NORTHERLY RIGHT-OF-WAY LINE OF COMMONS BOULEVARD; THENCE SOUTHWESTERLY 26.20 FEET ALONG THE ARC OF A 165.00 FOOT RADIUS CURVE TO THE LEFT (CENTER BEARS SOUTH $22^{\circ}54'31''$ EAST AND THE CHORD BEARS SOUTH $62^{\circ}32'32''$ WEST 26.17 FEET WITH A CENTRAL ANGLE OF $09^{\circ}05'55''$) ALONG SAID NORTHERLY RIGHT-OF-WAY LINE OF COMMONS BOULEVARD; THENCE SOUTH $57^{\circ}59'34''$ WEST 26.05 FEET ALONG SAID NORTHERLY RIGHT-OF-WAY LINE OF COMMONS BOULEVARD TO THE POINT OF BEGINNING.

SOUTH PARCEL:

A PARCEL OF LAND LOCATED IN THE NORTHEAST QUARTER OF THE SOUTHWEST QUARTER OF SECTION 20 ALL IN TOWNSHIP 3 SOUTH, RANGE 5 EAST, SALT LAKE BASE AND MERIDIAN, WASATCH COUNTY, UTAH DESCRIBED AS FOLLOWS:

BEGINNING AT A POINT ON THE EASTERLY RIGHT-OF-WAY LINE OF STATE HIGHWAY 40 PROJECT NO. F-019-1(1), SAID POINT BEING NORTH 0°08'37" WEST 687.06 FEET ALONG THE SECTION LINE AND EAST 659.19 FEET FROM THE 1999 WASATCH COUNTY SURVEY ALUMINUM CAP MONUMENT MARKING THE SOUTHWEST QUARTER CORNER OF SECTION 20, TOWNSHIP 3 SOUTH, RANGE 5 EAST, SALT LAKE BASE AND MERIDIAN (BASIS OF BEARINGS FOR THIS DESCRIPTION IS SOUTH 04°04'03" EAST 2857.85 FEET ALONG A LINE DEFINED BY WASATCH COUNTY WATER SERVICE AREA NO. 1 SURVEY CONTROL MONUMENTS NO. 706 AND NO. 708 (BOTH ALUMINUM PIPE CAP MONUMENTS) SEE THE SURVEY CONTROL SHEET FOR THE CENTRAL UTAH WATER CONSERVANCY DISTRICT, WASATCH COUNTY WATER EFFICIENCY PROJECT, DRAWING NO. G-8 AS RECORDED IN BOOK 630 AT PAGES 766-767 AND AS ENTRY NO. 259146 OF THE WASATCH COUNTY RECORDS); THE PARCEL 2 DESCRIPTION AS RECORDED AS ENTRY NO. 396936 OF SAID RECORDS, WHICH SAID PARCEL 2 BEARINGS ARE ROTATED 0°01'39" COUNTERCLOCKWISE TO AGREE WITH THE ABOVE DESCRIBED BASIS OF BEARINGS; THENCE ALONG SAID EASTERLY RIGHT OF WAY LINE NORTH 32°00'02" WEST 748.34 FEET ALONG THE EASTERLY RIGHT OF WAY LINE OF SAID STATE HIGHWAY 40 TO THE BOUNDARY LINE OF WASATCH COMMONS SUBDIVISION, SAID BOUNDARY ALSO BEING THE SOUTH RIGHT OF WAY LINE FOR COMMONS BOULEVARD; THENCE ALONG THE SAID SOUTH RIGHT OF WAY LINE AND BOUNDARY LINE NORTH 57°57'55" EAST 146.97 FEET; THENCE NORTHEASTERLY 33.19 FEET ALONG A 35.50 FEET RADIUS CURVE TO THE RIGHT THROUGH A CENTRAL ANGLE OF 53°33'54" AND A LONG CHORD OF NORTH 84°44'52" EAST 31.99 FEET; THENCE SOUTHEASTERLY 31.12 FEET ALONG A 94.50 FEET RADIUS REVERSE CURVE TO THE LEFT THROUGH A CENTRAL ANGLE OF 18°52'06" AND A LONG CHORD OF SOUTH 77°54'14" EAST 30.98 FEET; THENCE SOUTHEASTERLY 34.27 FEET ALONG A 35.50 FEET RADIUS REVERSE CURVE TO THE RIGHT THROUGH A CENTRAL ANGLE OF 55°18'12" AND A LONG CHORD OF SOUTH 59°41'11" EAST 32.95 FEET TO A POINT ON THE WEST RIGHT OF WAY LINE FOR GREEN VALLEY ROAD; THENCE ALONG SAID RIGHT OF WAY LINE AND SAID BOUNDARY LINE SOUTH 32°02'05" EAST 10.00 FEET; THENCE NORTH 57°57'55" EAST 12.00 FEET; THENCE SOUTH 32°02'05" EAST 44.05 FEET; THENCE SOUTHEASTERLY 14.86 FEET ALONG A 153.00 FEET RADIUS CURVE TO THE LEFT THROUGH A CENTRAL ANGLE OF 5°33'55" AND A LONG CHORD OF SOUTH 34°49'02" EAST 14.86 FEET; THENCE SOUTH 37°36'00" EAST 36.75 FEET; THENCE SOUTHEASTERLY 59.80 FEET ALONG A 447.00 FEET RADIUS CURVE TO

THE RIGHT THROUGH A CENTRAL ANGLE OF 7°39'55" AND A LONG CHORD OF SOUTH 33°46'03" EAST 59.76 FEET; THENCE SOUTH 29°56'05" EAST 24.60 FEET; THENCE SOUTHEASTERLY 92.27 FEET ALONG A 2517.50 FEET RADIUS CURVE TO THE LEFT THROUGH A CENTRAL ANGLE OF 2°06'00" AND A LONG CHORD OF SOUTH 30°59'05" EAST 92.26 FEET; THENCE SOUTH 32°02'05" EAST 544.50 FEET; THENCE NORTH 89°59'12" WEST 270.18 FEET TO THE POINT OF BEGINNING.