

0  
25

E

WHEN RECORDED MAIL TO:

Jordan Valley Water  
Conservancy District  
Attn: Property Manager  
8215 South 1300 West  
West Jordan, Utah 84088



ENT 25944:2016 PG 1 of 25  
JEFFERY SMITH  
UTAH COUNTY RECORDER  
2016 Mar 28 3:52 pm FEE 0.00 BY EO  
RECORDED FOR JORDAN VALLEY WATER

[PARCEL ID # 58-021-0031  
58-021-0096]

ENCROACHMENT AGREEMENT

This Encroachment Agreement is made as of March 24, 2016, between the Jordan Valley Water Conservancy District, a water conservancy district organized under the laws of the State of Utah ("District"), and Lehi City, a Utah municipality ("City").

RECITALS:

- A. The District holds an easement and right-of-way (collectively referred to as the "Easement/Right-of-Way," and described on attached Exhibit A) under authority of a written agreement, and it utilizes, or will utilize, them for constructing, installing, operating, maintaining, inspecting, repairing and/or replacing a water pipeline and related facilities;
- B. The City has requested permission to encroach upon the Easement/Right-of-Way of the District in a manner more particularly specified in this Agreement; and,
- C. The District is willing to agree to the encroachment, upon the terms and conditions set forth in this Agreement.

TERMS:

The parties agree:

1. (a) The District hereby agrees to encroachment upon the Easement/Right-of-Way by the City, but only to this extent and for this purpose: The City may construct, operate and maintain: four (4) 12" steel casings for future utilities; one (1) 12" steel casing for power, communications, and control; one (1) 15" HDPE Storm Drain pipeline; one (1) 8" PVC sanitary sewer pipeline within one (1) 16" steel casing; one (1) 24" class 50 ductile iron culinary water pipeline within one (1) 36" steel casing; one (1) 12" class 50 ductile iron secondary water pipeline within one (1) 24" steel casing; standard roadway improvements consisting of up to four (4) additional feet of soil/compaction fills, asphalt and concrete curb, gutter and sidewalk, as shown on attached Exhibit B.1; and, one (1) 16" welded steel culinary water pipeline within one (1) 30" steel casing, as shown on attached Exhibit B.2 (all collectively referred to as the "Encroachment Improvements").

(b) By entering into this Agreement, the District is giving its consent for the City to encroach upon the Easement/Right-of-Way held by the District. However, the District does not hold fee title to the real property within the Easement/Right-of-Way. Accordingly, the District does not warrant title to the underlying property, nor does the District represent or warrant that the City's encroachment on or across the District's Easement/Right-of-Way: (i) is suitable for the City's purposes; (ii) is allowed by the terms or conditions of the District's Easement/Right-of-Way agreement with those who hold fee title to the underlying real property; and, (iii) does not require the consent of others to encroach upon the District's Easement/Right-of-Way, which consent may be withheld for any or no reason.

(c) This consent for encroachment is granted by the District only to the extent of, and with no actual or implied diminishment of, the District's rights and interests in the Easement/Right-of-Way and without any express or implied warranty of any kind.

2. The City shall comply with the District's Guidelines for Encroachment upon the Easement/Right-of-Way as set forth in attached Exhibit C.

3. (a) The City and its contractor(s) and agent(s) shall perform all work within the Easement/Right-of-Way in accordance with the plans, drawings, guidelines, and/or maps set forth in Exhibit B, and in a manner satisfactory to the District.

(b) If the District's 48" pipeline is exposed during construction of the Encroachment Improvements, the City, at its expense, shall back-fill the District's pipeline using CLSM material up to the springline of the pipeline, except as noted on sheet C-504 of attached Exhibit B.2.

(c) The City shall construct and maintain, at its expense, a flared drive approach for District use, as shown on sheet PP-2A of attached Exhibit B.1 and attached Exhibit B.3.

4. If the installation, construction, operation, maintenance, repair, replacement or inspection of any structures, equipment, facilities or pipeline(s) of the District located, or to be located, in the Easement/Right-of-Way should be made more expensive by reason of the Encroachment Improvements or the activities of the City, the City shall pay to the District the full amount of such additional expense upon receipt of an itemized statement. The District has the right to remove any/all of the Encroachment Improvements without any liability to the City for removal, damages, or any cost or expense, and the City, at its sole

expense and labor, may replace and/or re-install them within the Easement/Right-of-Way consistent with the terms of this Agreement.

5. The City shall construct, install, use, maintain, repair and replace its Encroachment Improvements in such a manner as not to (i) damage or obstruct the District's structures, equipment, facilities and/or pipelines; or, (ii) interfere with the installation, construction, operation, maintenance, inspection, repair or replacement of the District's structures, equipment, facilities and pipelines.

6. In consideration of the District agreeing to encroachment upon the Easement/Right-of-Way, the City shall:

(a) Indemnify, defend and hold harmless the District, its agents, employees, officers, trustees, assigns and successors from and against all claims, demands, causes of action, liability or judgment of any kind, including attorney's fees and costs, which directly or indirectly arise from the negligence of the City or its agent(s) or contractor(s), or from the existence, construction, installation, operation, maintenance, repair, replacement, condition, use or presence of the Encroachment Improvements within the Easement/Right-of-Way;

(b) Release the District and its agents, employees, officers, trustees, assigns and successors, from liability for all loss or damage of every description or kind whatsoever which may result to the City from the construction, installation, operation, maintenance, inspection, repair and replacement of District structures, equipment, pipelines and facilities within the Easement/Right-of-Way, provided the loss or damage was not due solely to the negligence of the District; and,

(c) Hereby acknowledge that it accesses and uses the Easement/Right-of-Way at the City's risk and hazard and, without limiting the generality of the foregoing, the City agrees that the District shall not be responsible for any harm, damage or injury that may be suffered or incurred by the City, its agents, employees, contractors, licensees, guests or invitees associated with the use or condition of the Easement/Right-of-Way, except to the extent the harm, damage or injury was caused by the reckless or intentional misconduct of the District.

7. The City and its contractor(s) and agent(s) shall comply with all applicable laws, ordinances, rules, and regulations enacted or promulgated by any federal, state, or local governmental body having jurisdiction over the Encroachment Improvements and/or the Easement/Right-of-Way.

8. The provisions of this Agreement shall inure to the benefit of and be binding upon the successors and assigns of the parties; provided, however, that no such successor or assign of the City shall have the right to use, alter, or modify the Encroachment Improvements in a manner which will increase the expense or burden to the District of the City's encroachment on the Easement/Right-of-Way.

9. (a) This Agreement, and the encroachment granted to the City by this Agreement, shall terminate without further notice or condition if (i) the City does not continuously use the Encroachment Improvements as intended by this Agreement for any twelve (12) month period; or, (ii) the City breaches this Agreement.

(b) In the event of termination, the City, at its expense, shall immediately remove the Encroachment Improvements from the Easement/Right-of-Way and restore the surface of the Easement/Right-of-Way to its pre-encroachment condition.

10. (a) The City may assign this Agreement with the prior written consent of the District, which consent shall not be unreasonably withheld.

(b) The District may assign this Agreement.

11. This Agreement may be amended only by written instrument executed by all parties.

12. All of the grants, covenants, terms, provisions and conditions in this Agreement shall run with the land and shall be binding upon and inure to the benefit of the successors, assigns, heirs, executors and administrators of the parties.

13. This Agreement, including exhibits, constitutes the entire agreement of the parties and supersedes all prior understandings, representations or agreements of the parties regarding its subject matter.

14. Each individual executing this Agreement does hereby represent and warrant that he or she has been duly authorized to sign this Agreement in the capacity and for the entities identified.

15. The parties shall perform those acts and/or sign all documents required by this Agreement and which may be reasonably necessary to effectuate the terms of this Agreement.

16. Any party may record this Agreement.

"District":

Jordan Valley Water Conservancy District

Dated: 3/24/2016

By: Richard P. Bay  
Richard P. Bay  
Its General Manager/CEO

"City":

Lehi City

Dated: 3/16/16

By: Scott Wilson  
Its: Mayor

STATE OF UTAH )  
 )  
 :ss.  
COUNTY OF SALT LAKE )

The foregoing instrument was acknowledged before me this 24<sup>th</sup> day of March 2016, by Richard P. Bay as General Manager/CEO of the Jordan Valley Water Conservancy District.

Jacqueline E. Maas  
Notary Public



STATE OF UTAH )  
 )  
 :ss.  
COUNTY OF VT )

The foregoing instrument was acknowledged before me this 16 day of March, by Bert Wilson as Mayor of Lehi City.

Teisha M. Wilson  
Notary Public





## EXHIBIT A

## DESCRIPTION OF DISTRICT'S EASEMENT/RIGHT-OF-WAY

A part of an entire tract being located in the Northeast Quarter of the Southwest Quarter of Section 2, Township 5 South, Range 1 West, Salt Lake Base and Meridian, Utah County, Utah, described as follows:

COMMENCING at the northwest corner of the Southwest Quarter of Section 2, Township 5 South, Range 1 West, Salt Lake Base and Meridian; thence North  $89^{\circ}32'18''$  East 1764.51 feet along the north line of said Southwest Quarter; thence South  $00^{\circ}16'32''$  East 228.44 feet to a point on the southerly right of way of 2100 North Street, Utah Department of Transportation Project MP-R399(41), and the north boundary of said tract, said point being the point of BEGINNING and running thence North  $84^{\circ}54'28''$  East 50.18 feet along said southerly right of way; thence South  $00^{\circ}16'32''$  East 112.53 feet to a point 10.00 feet perpendicularly distant westerly from the centerline of the Utah Lake Distributing Canal as described in a Notice of Right of Way recorded as Entry Number 30678:1984; thence parallel with said canal centerline the following four (4) courses: (1) South  $22^{\circ}45'02''$  West 377.88 feet to a point on a 410.00 feet radius curve to the left; (2) southerly 164.82 feet along the arc of said curve through a central angle of  $23^{\circ}02'00''$ , said arc having a chord bearing South  $11^{\circ}14'02''$  West 163.72 feet; (3) South  $00^{\circ}16'58''$  East 352.90 feet to a point on a 810.00 feet radius curve to the left; and (4) southerly 130.99 feet along the arc of said curve through a central angle of  $09^{\circ}15'56''$ , said arc having a chord bearing South  $04^{\circ}54'56''$  East 130.85 feet to a point on the north boundary of Lot 1, Country Mile Plat A subdivision, and the south boundary of said entire tract, said point being North  $00^{\circ}17'58''$  West 1328.81 feet along the east line of said Southwest Quarter and South  $89^{\circ}35'25''$  West 1011.27 feet along the north boundary of said Lot 1 from the south quarter corner of said Section 2; thence South  $89^{\circ}35'25''$  West 50.60 feet along said north boundary to a point on a non-tangent 860.00 feet radius curve to the right, said point being 60.00 feet perpendicularly distant westerly from said canal centerline; thence parallel with said canal centerline the following four (4) courses: (1) northerly 131.04 feet along the arc of said curve through a central angle of  $08^{\circ}43'49''$ , said arc having a chord bearing North  $04^{\circ}38'53''$  West 130.91 feet; (2) North  $00^{\circ}16'58''$  West 352.90 feet to a point on a 460.00 feet radius curve to the right; (3) northerly 184.92 feet along the arc of said curve through a central angle of  $23^{\circ}02'00''$ , said arc having a chord bearing North  $11^{\circ}14'02''$  East 183.68 feet; and (4) North  $22^{\circ}45'02''$  East 367.70 feet; thence North  $00^{\circ}16'32''$  West 98.13 feet to the southerly right of way of said 2100 North Street and the point of BEGINNING, containing 56841 square feet or 1.305 acres.

Together with:

A part of an entire tract of land located in the Southeast Quarter of the Southwest Quarter of Section 2, Township 5 South, Range 1 West, Salt Lake Base and Meridian, Utah County, Utah, described as follows:

BEGINNING at a point on the south line of the southwest quarter of said Section 2, said

point being 8.00 feet perpendicularly distant westerly from the centerline of the Utah Lake Distributing Canal as described in a Notice of Right of Way recorded as Entry Number 30678:1984, said point also being South 89°38'34" West 541.16 feet along said south line from the south quarter corner of said Section 2, and running thence South 89°38'34" West 24.01 feet along said south line to the westerly right of way of said canal being 30.00 feet perpendicularly distant westerly from the centerline of said canal; thence North 23°58'58" West 22.92 feet along said westerly right of way to the north boundary of said entire tract being 21.00 feet perpendicularly distant northerly from said south line; thence North 89°38'34" East 24.01 feet along said north boundary and parallel with said south line to a point 8.00 feet perpendicularly distant westerly from the centerline of said canal; thence South 23°58'58" East 22.92 feet parallel with said centerline to the point of BEGINNING, containing 504 square feet or 0.012 acres.

EXHIBIT B  
ENCROACHMENT IMPROVEMENTS

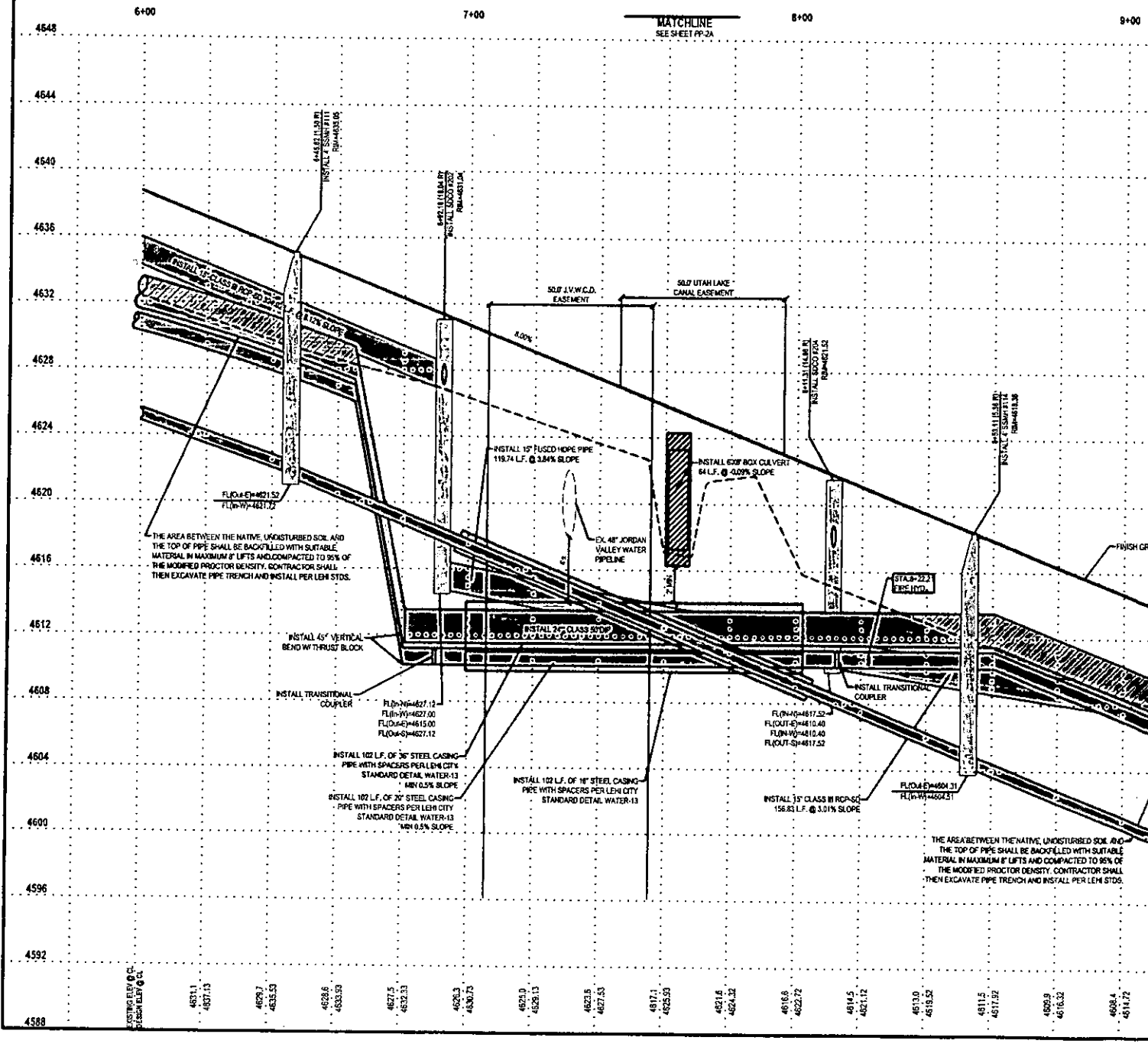
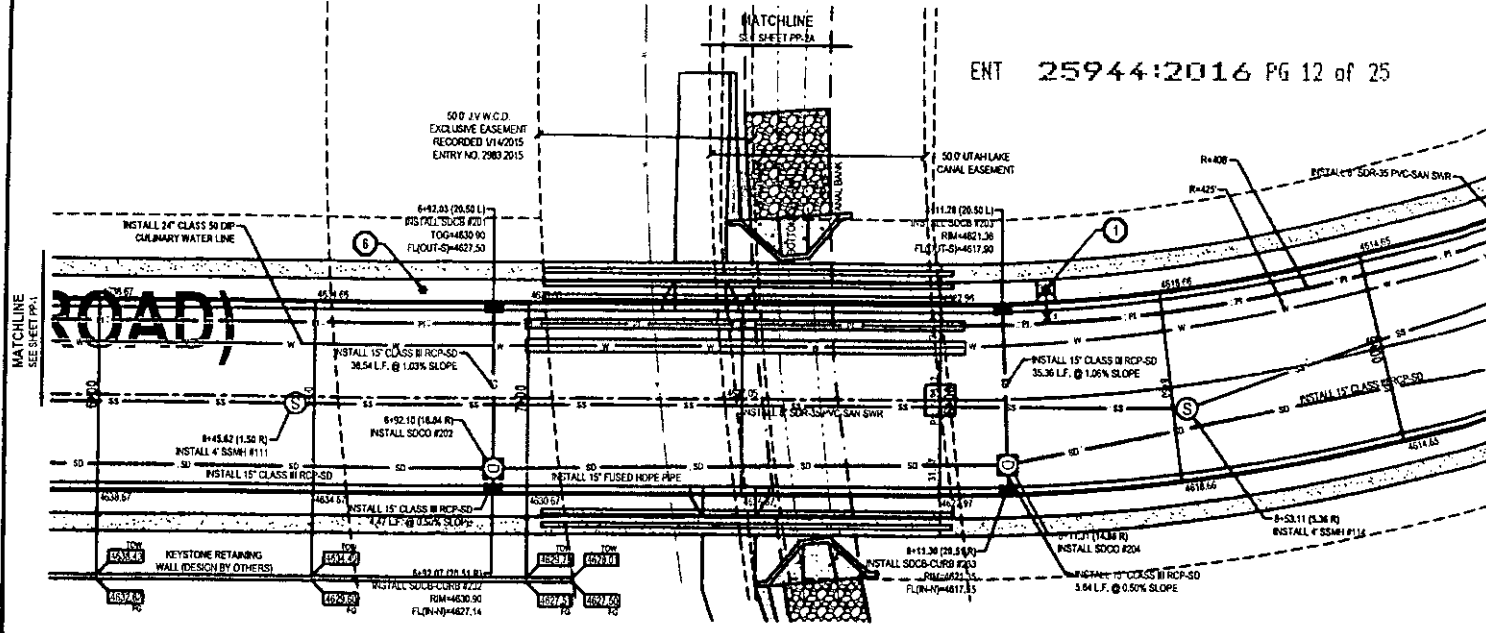

THE AREA BETWEEN THE NATIVE UNDISTURBED SOIL AND THE TOP OF PIPE SHALL BE BACKFILLED WITH SUITABLE MATERIAL IN MAXIMUM 8' LIFTS AND COMPACTED TO 95% OF THE MODIFIED PROCTOR DENSITY. CONTRACTOR SHALL THEN EXCAVATE PIPE TRENCH AND INSTALL PER LEH STDs.

THE AREA BETWEEN THE NATIVE UNDISTURBED SOIL AND THE TOP OF PIPE SHALL BE BACKFILLED WITH SUITABLE MATERIAL IN MAXIMUM 8' LIFTS AND COMPACTED TO 95% OF THE MODIFIED PROCTOR DENSITY. CONTRACTOR SHALL THEN EXCAVATE PIPE TRENCH AND INSTALL PER LEH STDs.

Station	6+00	6+01	6+02	6+03	6+04	6+05	6+06	6+07	6+08	6+09	6+10	6+11	6+12	6+13	6+14	6+15	6+16	6+17	6+18	6+19	6+20	6+21	6+22	6+23	6+24	6+25	6+26	6+27	6+28	6+29	6+30	6+31	6+32	6+33	6+34	6+35	6+36	6+37	6+38	6+39	6+40	6+41	6+42	6+43	6+44	6+45	6+46	6+47	6+48	6+49	6+50	6+51	6+52	6+53	6+54	6+55	6+56	6+57	6+58	6+59	6+60																																																																																																																																												
Elevation	4638.00	4637.75	4637.50	4637.25	4637.00	4636.75	4636.50	4636.25	4636.00	4635.75	4635.50	4635.25	4635.00	4634.75	4634.50	4634.25	4634.00	4633.75	4633.50	4633.25	4633.00	4632.75	4632.50	4632.25	4632.00	4631.75	4631.50	4631.25	4631.00	4630.75	4630.50	4630.25	4630.00	4629.75	4629.50	4629.25	4629.00	4628.75	4628.50	4628.25	4628.00	4627.75	4627.50	4627.25	4627.00	4626.75	4626.50	4626.25	4626.00	4625.75	4625.50	4625.25	4625.00	4624.75	4624.50	4624.25	4624.00	4623.75	4623.50	4623.25	4623.00	4622.75	4622.50	4622.25	4622.00	4621.75	4621.50	4621.25	4621.00	4620.75	4620.50	4620.25	4620.00	4619.75	4619.50	4619.25	4619.00	4618.75	4618.50	4618.25	4618.00	4617.75	4617.50	4617.25	4617.00	4616.75	4616.50	4616.25	4616.00	4615.75	4615.50	4615.25	4615.00	4614.75	4614.50	4614.25	4614.00	4613.75	4613.50	4613.25	4613.00	4612.75	4612.50	4612.25	4612.00	4611.75	4611.50	4611.25	4611.00	4610.75	4610.50	4610.25	4610.00	4609.75	4609.50	4609.25	4609.00	4608.75	4608.50	4608.25	4608.00	4607.75	4607.50	4607.25	4607.00	4606.75	4606.50	4606.25	4606.00	4605.75	4605.50	4605.25	4605.00	4604.75	4604.50	4604.25	4604.00	4603.75	4603.50	4603.25	4603.00	4602.75	4602.50	4602.25	4602.00	4601.75	4601.50	4601.25	4601.00	4600.75	4600.50	4600.25	4600.00	4599.75	4599.50	4599.25	4599.00	4598.75	4598.50	4598.25	4598.00	4597.75	4597.50	4597.25	4597.00	4596.75	4596.50	4596.25	4596.00	4595.75	4595.50	4595.25	4595.00	4594.75	4594.50	4594.25	4594.00	4593.75	4593.50	4593.25	4593.00	4592.75	4592.50	4592.25	4592.00	4591.75	4591.50	4591.25	4591.00	4590.75	4590.50	4590.25	4590.00	4589.75	4589.50	4589.25	4589.00	4588.75	4588.50	4588.25	4588.00

**SALT LAKE CITY**  
45 W. 10000 S., Suite 500  
Sandy, UT 84070  
Phone: 801.255.0529

**LAYTON**  
Phone: 801.547.1100

**TOOELE**  
Phone: 435.843.3590

**CEDAR CITY**  
Phone: 435.865.1453

**RICHFIELD**  
Phone: 435.896.2983

[WWW.ENSIGNENG.COM](http://WWW.ENSIGNENG.COM)

FOR:  
GARDNER COMPANY  
80 SOUTH 400 WEST  
SALT LAKE CITY, UTAH 84101  
CONTACT:  
MARK MURDOCK  
PHONE: 801-915-1822

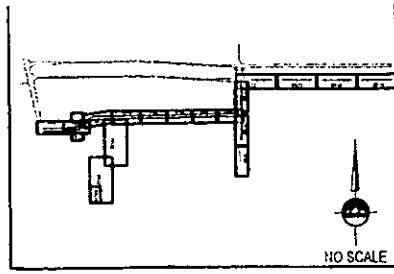

**KEYED NOTES**

- 1 INSTALL FIRE HYDRANT (COMPLETE) PER LEHI CITY STDS.
- 2 INSTALL 4" PERMANENT BLOWOFF VALVE PER LEHI CITY STDS.
- 3 INSTALL 6" PERMANENT BLOWOFF VALVE W/ (2) 24" B.V.'S PER LEHI CITY STDS.
- 4 DEFLECT WATER LINE UNDER STORM DRAIN OR INSTALL LOOP PER APWA PLAN 543.
- 5 INSTALL 14"x10" REDUCER PER LEHI CITY STDS.
- 6 INSTALL STREET LIGHTS PER LEHI CITY STDS.

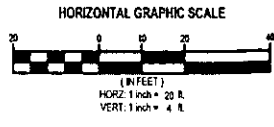
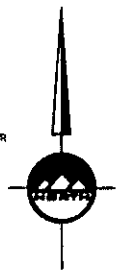
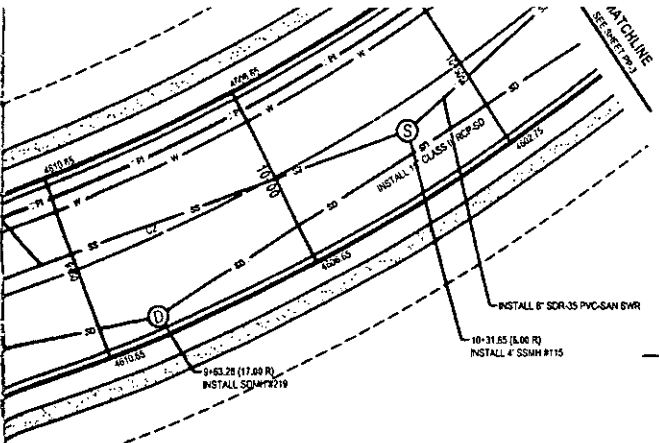

**HARDMAN WAY  
STA 6+00 TO 10+50**

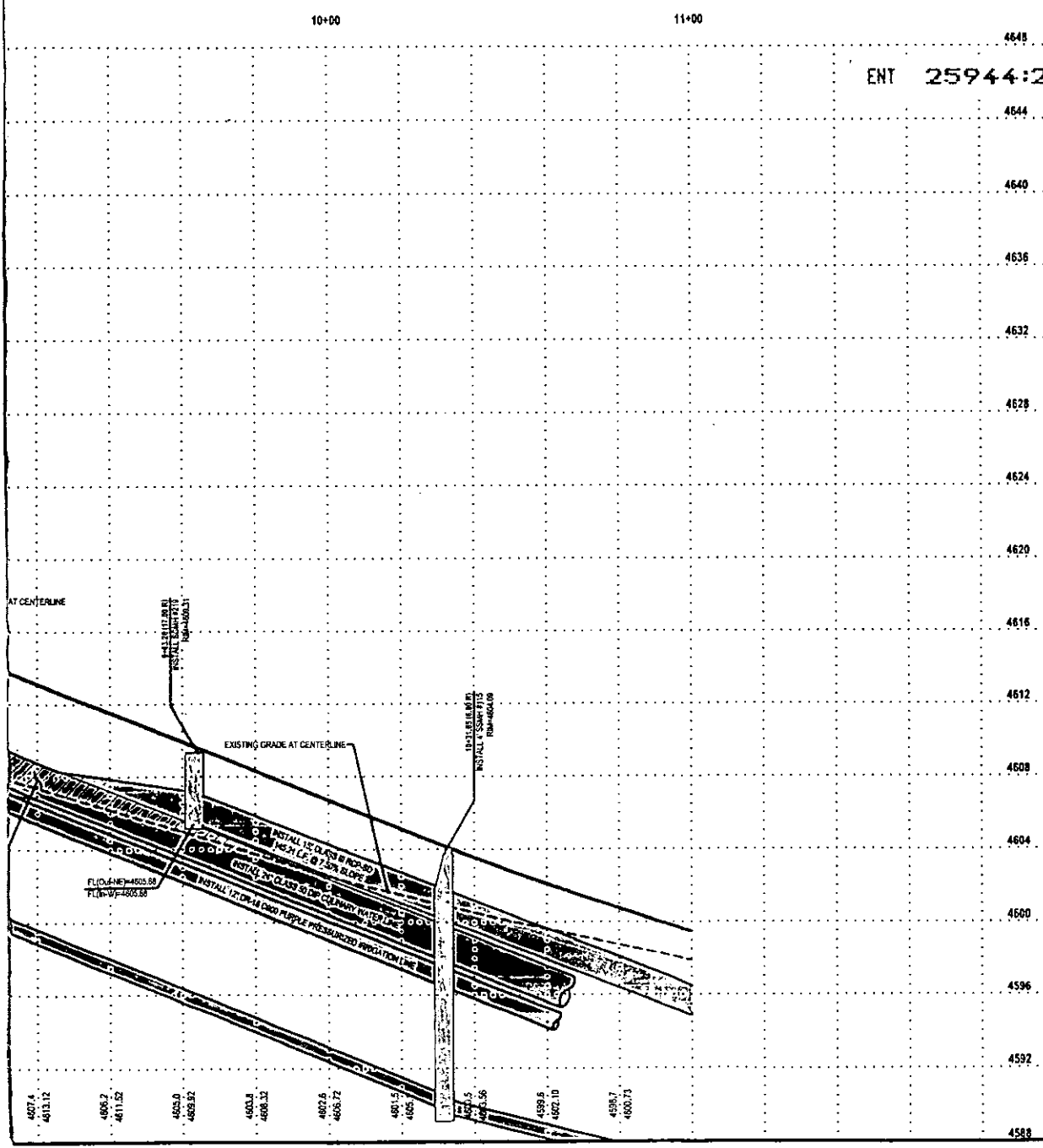

ENT 25944:2016 PG 13 of 25

**HARDMAN WAY**

**LEHI CITY, UTAH**



NO.	DATE	REVISION	BY
1	03-21-2016	SC NETWORKING	JAF

**PLAN AND PROFILE**

PROJECT NUMBER 63903	PRINT DATE 2/29/16
DRAWN BY DJM	CHECKED BY JAF
PROJECT MANAGER JAF	

**PP-2**

Exhibit B.1

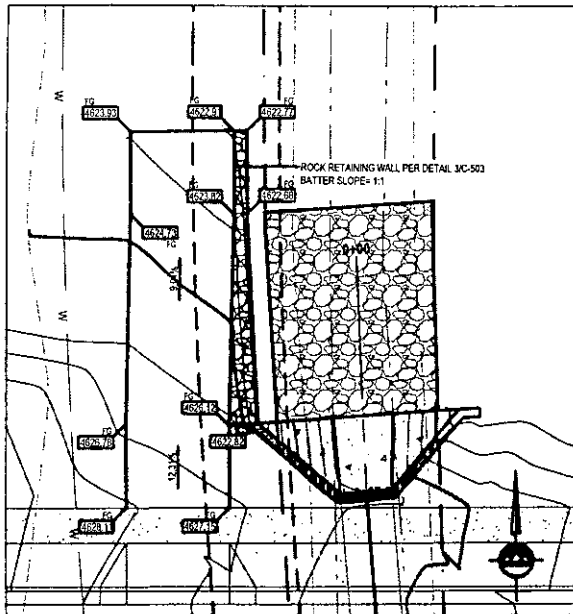

NORTH SIDE WALL DETAIL

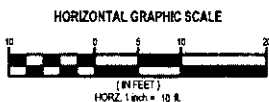
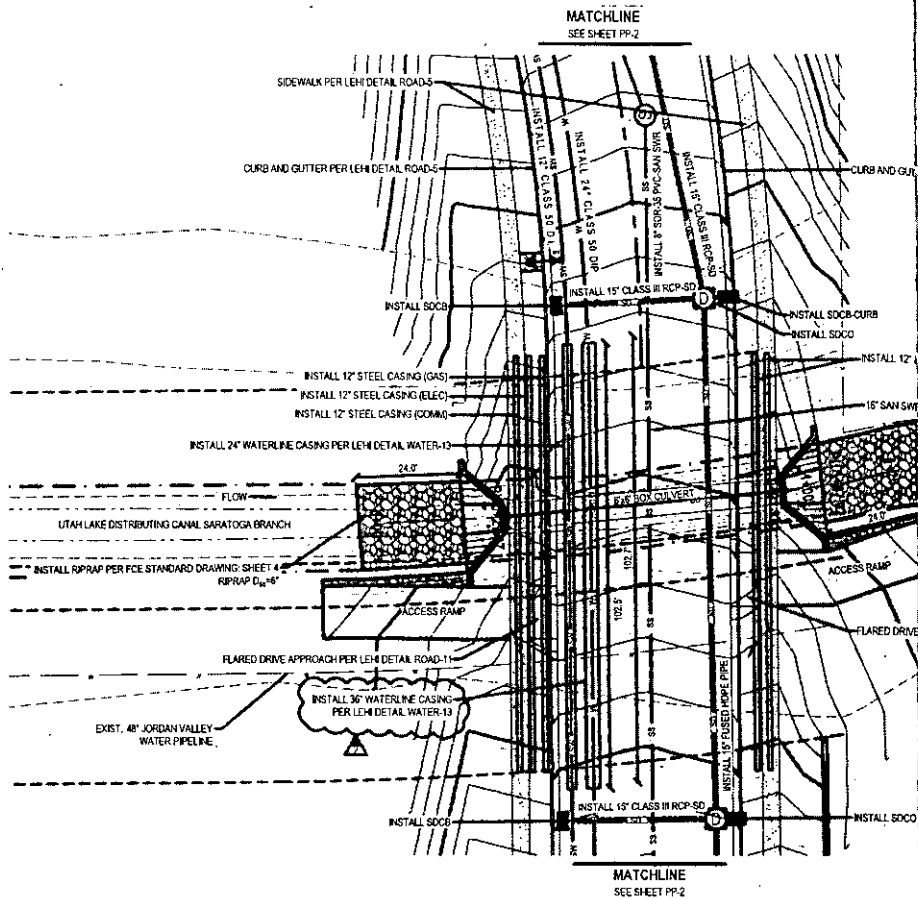

GENERAL NOTES:

- CONTRACTOR WILL BE REQUIRED TO PROVIDE APPROPRIATE BENDS AND THRUST BLOCKING TO INSTALL WATERLINE BENEATH CANAL.
- PRECASTER TO DESIGN AND SUBMIT BOX CULVERT STRUCTURAL DETAILS APPROVED BY A UTAH PROFESSIONAL ENGINEER. AT A MINIMUM, AN INNER CAGE AND OUTER CAGE WILL BE REQUIRED AND STRUCTURE SHALL BE DESIGNED TO ASTM C-1577 STANDARDS. BOX CULVERT TO BE INSTALLED PER MANUFACTURER SPECIFICATIONS.
- BACKFILL BEHIND WING WALLS WITH CLAY MATERIAL PER CANAL COMPANY STDS.
- CONTRACTOR WILL BE REQUIRED TO HOLD A PRE-CONSTRUCTION MEETING W/ BOX CULVERT MANUFACTURER, ENGINEER, AND LEHI CITY.
- ALL CONCRETE USED IN THE CONSTRUCTION SHALL HAVE A MIN. COMPRESSIVE STRENGTH OF 4,000 PSL. THE CONCRETE MIX SHALL INCLUDE BETWEEN 5 AND 7 PERCENT AIR ENTRAINMENT.
- THE CULVERT WAS DESIGNED WITH HL-93 LOADINGS.
- ALL CASINGS MUST BE EXTENDED BEYOND THE CANAL COMPANY RIGHT-OF-WAY LINE AND THE JWVWD EASEMENT LINE (80-FEET ON THE UPHILL SIDE AND 20-FEET ON THE DOWNHILL SIDE).
- CLAY MATERIAL PLACED BEHIND WING WALLS AND FOR TRENCH PLUGS MUST BE COMPACTED TO A MINIMUM OF 98% OF MODIFIED PROCTOR DENSITY.
- MINIMUM OF 18" STRUCTURAL FILL TO BE PLACED UNDER ENTIRE CULVERT INCLUDING WING WALLS AND APRON. ALL STRUCTURAL FILL BENEATH THE CANAL SHALL BE COMPACTED TO 92% OF MODIFIED PROCTOR PER ASTM D-1557.
- CLSM BACKFILL REQUIRED UP TO SPRINGLINE OF THE 48" JWVWD PIPELINE.

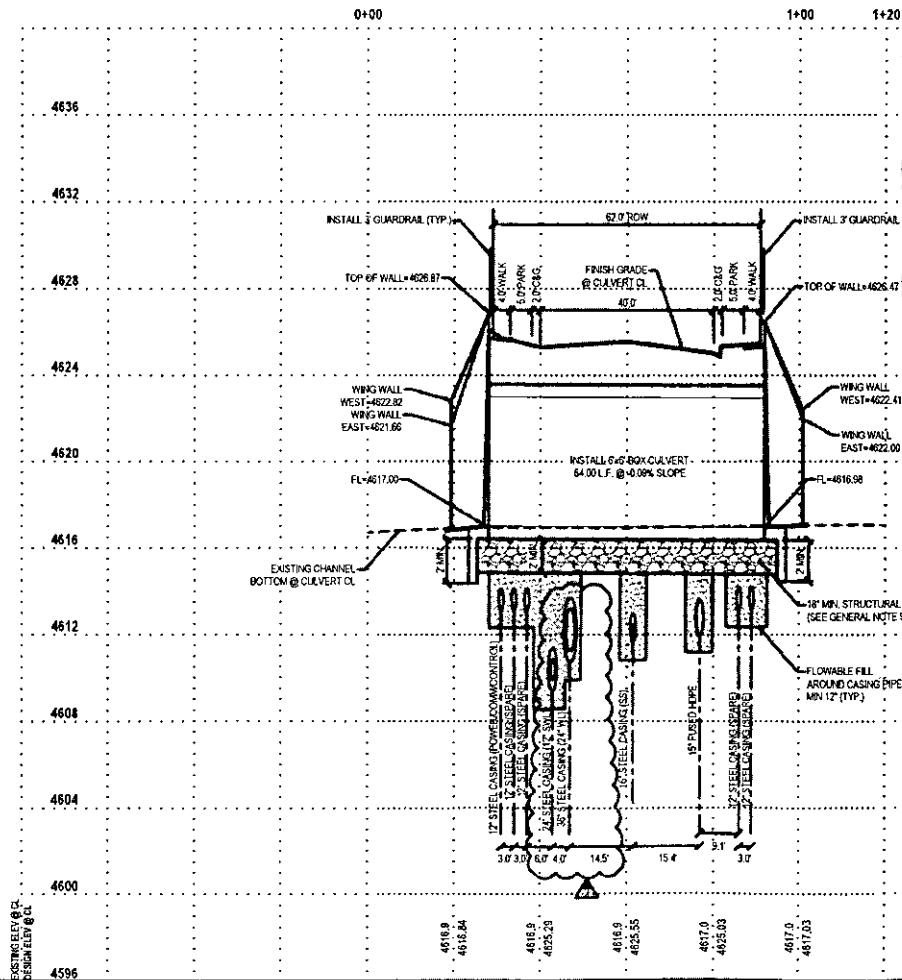
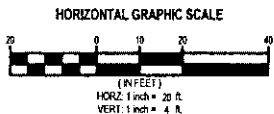

EXISTING ELEV @ CL  
DESIGN ELEV @ CL

4596 4600 4604 4608 4612 4616 4620 4624 4628 4632 4636

4618.9 4618.84 4618.9 4618.55 4617.0 4615.03 4617.0 4617.03

**SALT LAKE CITY**  
45 W. 10000 S., Suite 500  
Sandy, UT 84070  
Phone: 801.255.0529

**LAYTON**  
Phone: 801.547.1100

**TOOELE**  
Phone: 435.843.3590

**CEDAR CITY**  
Phone: 435.865.1453

**RICHFIELD**  
Phone: 435.896.2983

**WWW.ENSIGNENG.COM**

FOR  
GARDNER COMPANY  
80 SOUTH 400 WEST  
SALT LAKE CITY, UTAH 84101  
CONTACT:  
MARK BARDOCK  
PHONE: 801-415-1822

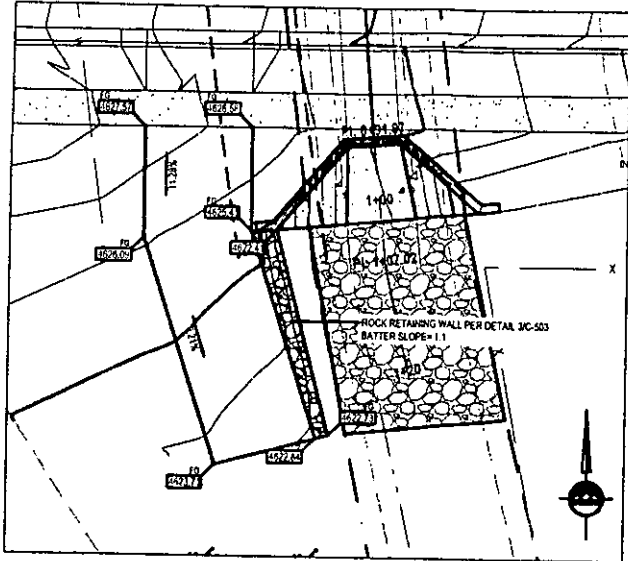
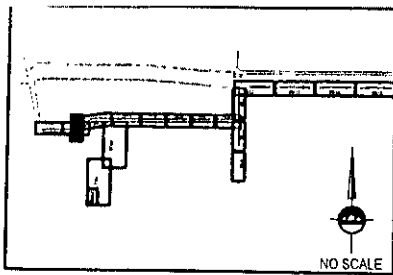

**SOUTH SIDE WALL DETAIL**

ENT 25944:2016 PG 15 of 25

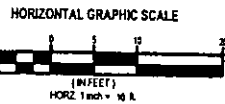

**STANDARD NOTES**

**1.1.4 CONSTRUCTION METHOD AND SEQUENCE:**

1. INSTALL SLEEVES AND ASSOCIATED UTILITIES WHERE APPLICABLE.
2. PREPARE CANAL BOTTOM AND SIDES FOR PLACEMENT OF PRECAST BOX CULVERT.
3. PLACE CUTOFF WALLS.
4. INSTALL BOX CULVERT.
5. BACKFILL STRUCTURE.

**1.2.4 GENERAL CULVERT NOTES:**

1. NOTIFICATION MUST BE GIVEN AT LEAST 24 HOURS PRIOR TO THE BEGINNING OF CONSTRUCTION WORK AND RE-NOTIFICATION OF RE-COMMENCEMENT OF WORK FOLLOWING ANY CESSATION OF WORK FOR MORE THAN 4 (FOUR) DAYS MUST BE GIVEN. CALL TODD ADAMS AND THE ULDC WATER MASTER. FAILURE TO DO SO WILL RESULT IN A \$5,000 FINE.
2. CONTACT INFORMATION FOR FCE, ULDC, AND JWVCD.
  - 2.1. TODD ADAMS, FCE, 801-756-0309
  - 2.2. BRUCE HEVEMAN, P.E., FCE, 801-756-0309
  - 2.3. JEFF MCWULFIN, PRESIDENT, ULDC, 801-641-3233
  - 2.4. KIM EVANG, WATER MASTER, SARATOGA CANAL, 801-641-4058
  - 2.5. GORDON BATT, 801-330-8807, JWVCD
3. ANY CHANGES IN DESIGN DRAWINGS AFTER THE ENCROACHMENT AGREEMENT HAS BEEN EXECUTED MUST BE REVIEWED AND ACCEPTED BY FCE AND ULDC.
4. WORK CANNOT INTERFERE WITH DELIVERY OF WATER. CONSTRUCTION WITHIN ULDC CORRIDORS MUST BE COMPLETED BETWEEN OCTOBER 15 AND APRIL 1.
5. ALL CONSTRUCTION WITHIN THE CANAL CORRIDOR MUST BE COMPLETED TO ULDC STANDARDS.
6. IF DISTURBED, THE CANAL OPERATION & MAINTENANCE ROAD (O&M ROAD) MUST BE RETURNED TO PRE-CONSTRUCTION STATE OR BETTER. FOLLOWING CONSTRUCTION THE O&M ROAD MUST BE AVAILABLE FOR USE BY ULDC PERSONNEL NO LATER THAN APRIL 1.
7. CANALS MAY COLLECT WATER DURING STORM EVENTS OR AT OTHER UNEXPECTED TIMES.
8. A JWVCD INSPECTOR MUST BE CONTACTED 48 HOURS PRIOR TO ANY CONSTRUCTION WITHIN THE EASEMENT AND MUST BE PRESENT ANY TIME THE 48" PIPELINE IS EXPOSED.
9. AN 18" MINIMUM SEPARATION BETWEEN TOP OF CASING AND BOTTOM OF THE EXIST. 48" JWVCD PIPE MUST BE FIELD CONFIRMED BY DISTRICT INSPECTOR PRIOR TO BACKFILL.

**1.3.3 BOX AND PIPE CULVERTS NOTES:**

1. CANAL FLOOR AND EMBANKMENT MATERIAL REMOVED FOR EXCAVATION SHALL BE REPLACED WITH 12-INCH MINIMUM THICKNESS OF 10<sup>-6</sup> CM/SEC PERMEABILITY CLAY MATERIAL, COMPACTED TO 98-PERCENT MODIFIED PROCTOR IN 8-INCH MAXIMUM LIFTS.
2. CANAL EMBANKMENT SHALL BE SHAPED TO MATCH THE EXISTING CANAL PRISM.
3. APPLICANT IS REQUIRED TO PERFORM COMPACTION TESTING AT THE APPLICANT'S COST. TEST RESULTS MUST BE SUBMITTED TO FCE. ALL FAILED MATERIAL SHALL BE REMOVED AND COMPACTED TO SPECIFICATIONS. TESTING MUST BE PERFORMED BY A LICENSED SOILS LAB.
4. OPEN-CUT TRENCHES SHALL BE CUT AT MINIMUM 2 HORIZONTAL TO 1 VERTICAL SO THAT BACKFILL CAN BE PROPERLY COMPACTED.
5. SIGNS MUST BE PLACED AT EACH ENTRANCE TO THE CANAL O&M ROAD THAT STATE:  
NO TRESPASSING, WARNING CANAL MAINTENANCE ROAD, AUTHORIZED PERSONNEL ONLY,  
NO SWIMMING OR TUBING.

**1.4.2 OPEN CUT OF CANAL CHANNEL NOTES:**

1. CANAL FLOOR AND EMBANKMENT MATERIAL REMOVED FOR EXCAVATION SHALL BE REPLACED WITH 12-INCH MINIMUM THICKNESS OF 10<sup>-6</sup> CM/SEC PERMEABILITY CLAY MATERIAL, COMPACTED TO 98-PERCENT MODIFIED PROCTOR IN 8-INCH MAX LIFTS.
2. CANAL EMBANKMENT SHALL BE SHAPED TO MATCH THE EXISTING CANAL PRISM.
3. APPLICANT IS REQUIRED TO PERFORM COMPACTION TESTING AT THE APPLICANT'S COST. TEST RESULTS MUST BE SUBMITTED TO FCE. ALL FAILED MATERIAL SHALL BE REMOVED AND COMPACTED TO SPECIFICATIONS. TESTING MUST BE PERFORMED BY A LICENSED SOILS LAB.
4. OPEN-CUT TRENCHES SHALL BE CUT AT MINIMUM 2 HORIZONTAL TO 1 VERTICAL SO THAT BACKFILL CAN BE PROPERLY COMPACTED.
5. CONTRACTOR TO NOTIFY TODD ADAMS OF FRANSON CIVIL ENGINEERS WHEN TRENCH PLUGS ARE INSTALLED. VERIFICATION OF TRENCH PLUG COMPLETION MUST BE PERFORMED BY FRANSON CIVIL ENGINEERS BEFORE BACKFILLING. TODD CAN BE REACHED AT 801-756-0309.

TER PER LEH DETAIL ROAD-5  
STEEL CASING (SPARE)  
CASING PER LEH DETAIL WATER-13  
INSTALL RIPRAP PER FCE STANDARD DRAWING, SHEET 4  
RIPRAP D<sub>50</sub>=4"  
APPROACH PER LEH DETAIL ROAD-11

4636
4632
4628
4624
4620
4616
4612
4608
4604
4600
4596

HARDMAN WAY

LEHI CITY, UTAH



REV	DATE	REVISION	BY
1	12/27/16	NO REVISIONS	JF
2	02/16/17	WATER AND STORM CHANGES	BS

**CULVERT PLAN AND PROFILE**

PROJECT NUMBER	PP-2A
DATE	2/24/16
DRAWN BY	JF
CHECKED BY	JF
PROJECT MANAGER	JF

**PP-2A**

Exhibit B.1

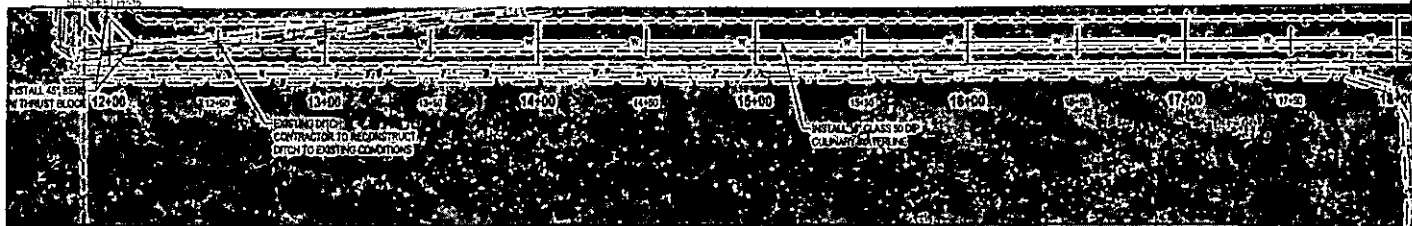

ENT 25944:2016 PG 16 of 25

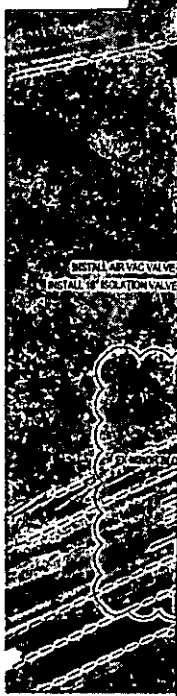

### SOUTH WATER LINE - STA 12+00 TO 17+00

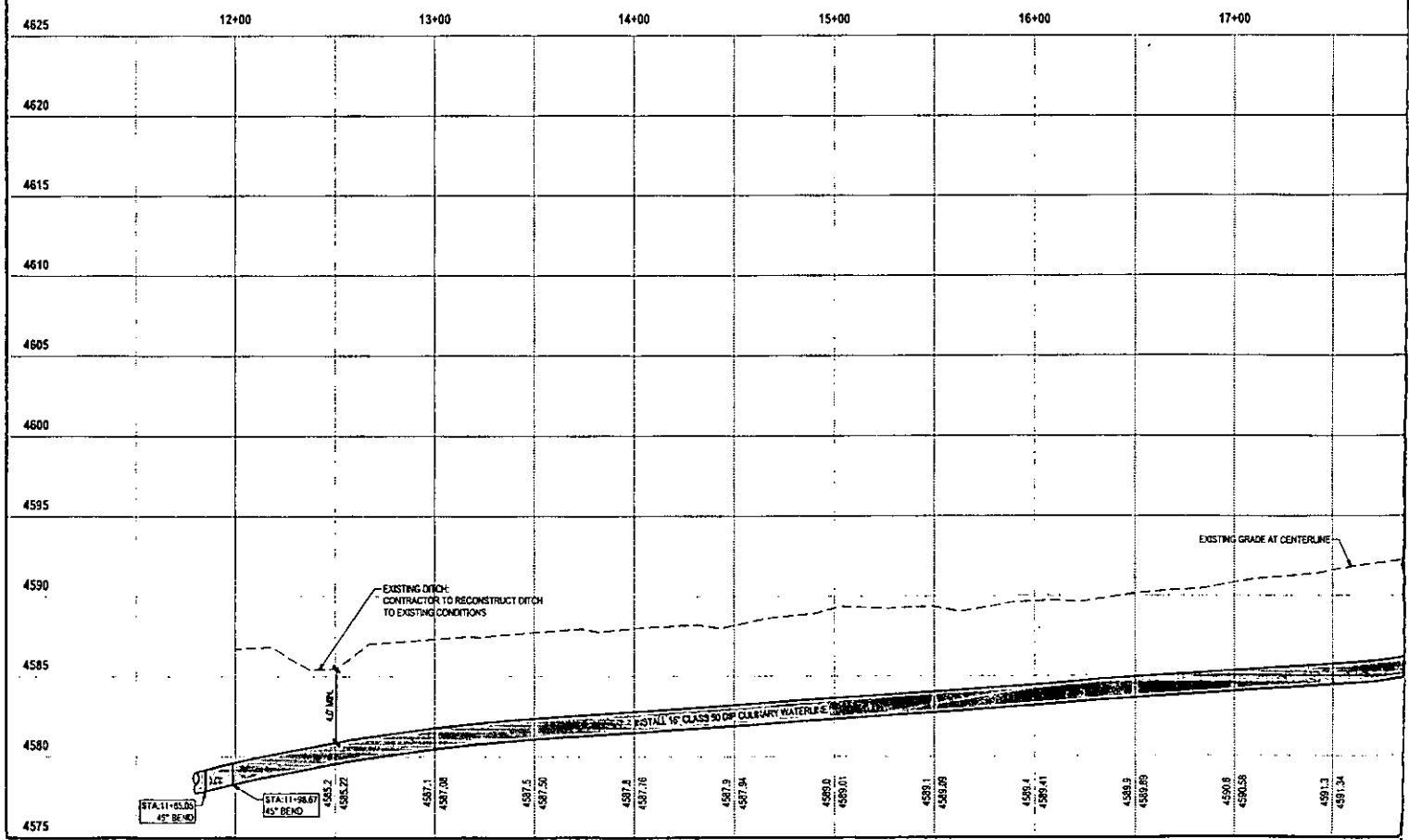



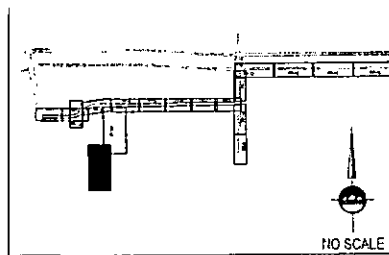
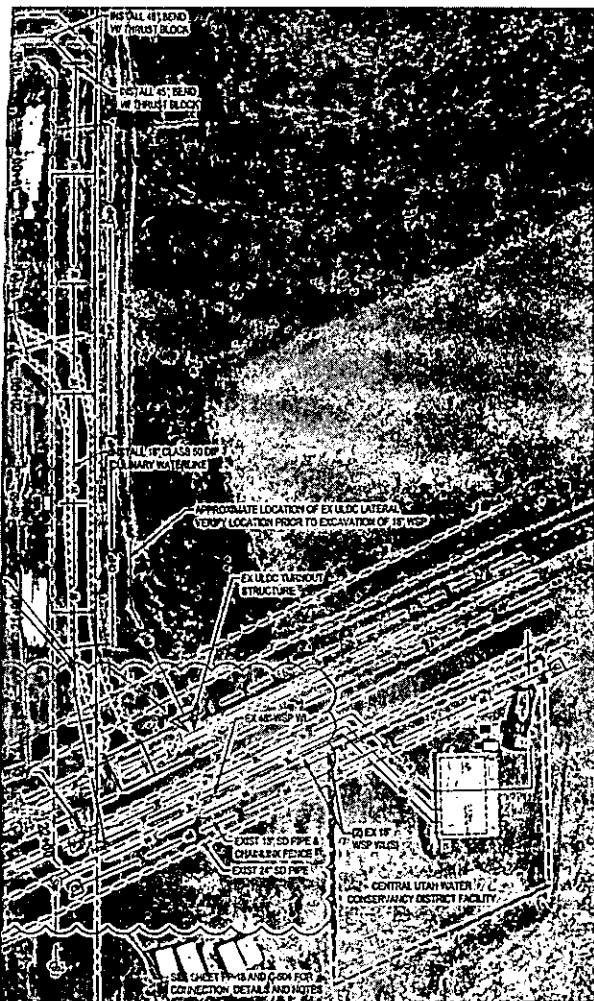

ENT 25944:2016 PG 17 of 25

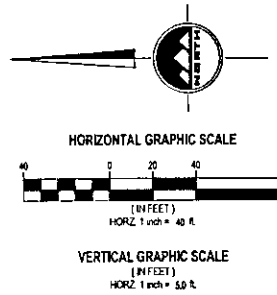

**ENSIGN**  
THE STANDARD IN ENGINEERING

**SALT LAKE CITY**  
45 W. 10000 S., Suite 500  
Sandy, UT 84070  
Phone: 801.255.0529

**LAYTON**  
Phone: 801.547.1100

**TOOELE**  
Phone: 435.843.3590

**CEDAR CITY**  
Phone: 435.865.1453

**RICHFIELD**  
Phone: 435.896.2983

WWW.ENSIGNENG.COM

FOR  
GARDNER COMPANY  
90 SOUTH 400 WEST  
SALT LAKE CITY, UTAH 84101  
CONTACT:  
MARK MURDOCK  
PHONE: 801-815-1822

HARDMAN WAY

LEHI CITY, UTAH

22+40

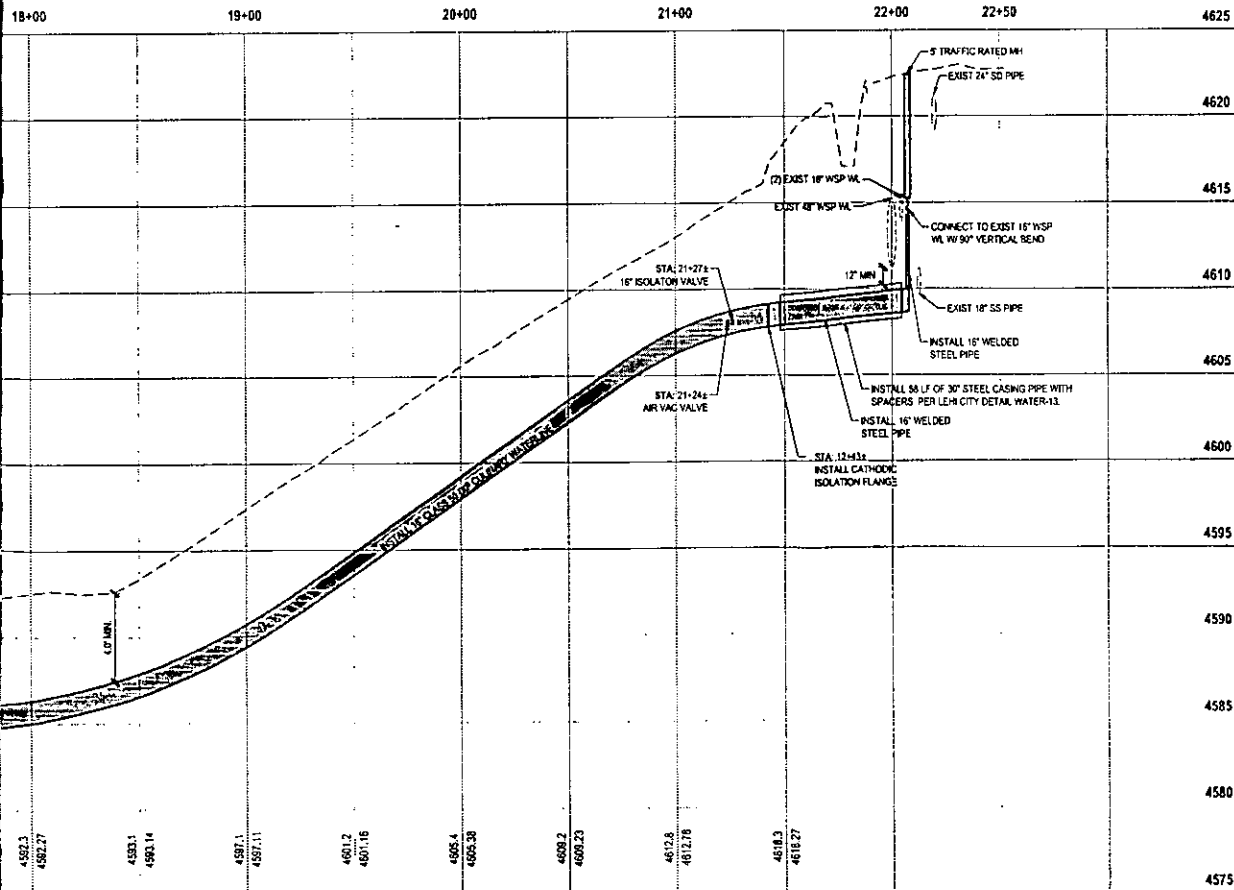

NO.	DATE	BY	REVISION
1			ISSUE FOR BIDDING

PLAN AND PROFILE

PROJECT NUMBER: 125714  
DRAWN BY: DJW  
PROJECT NUMBER: JCF

PP-17

Exhibit B.2

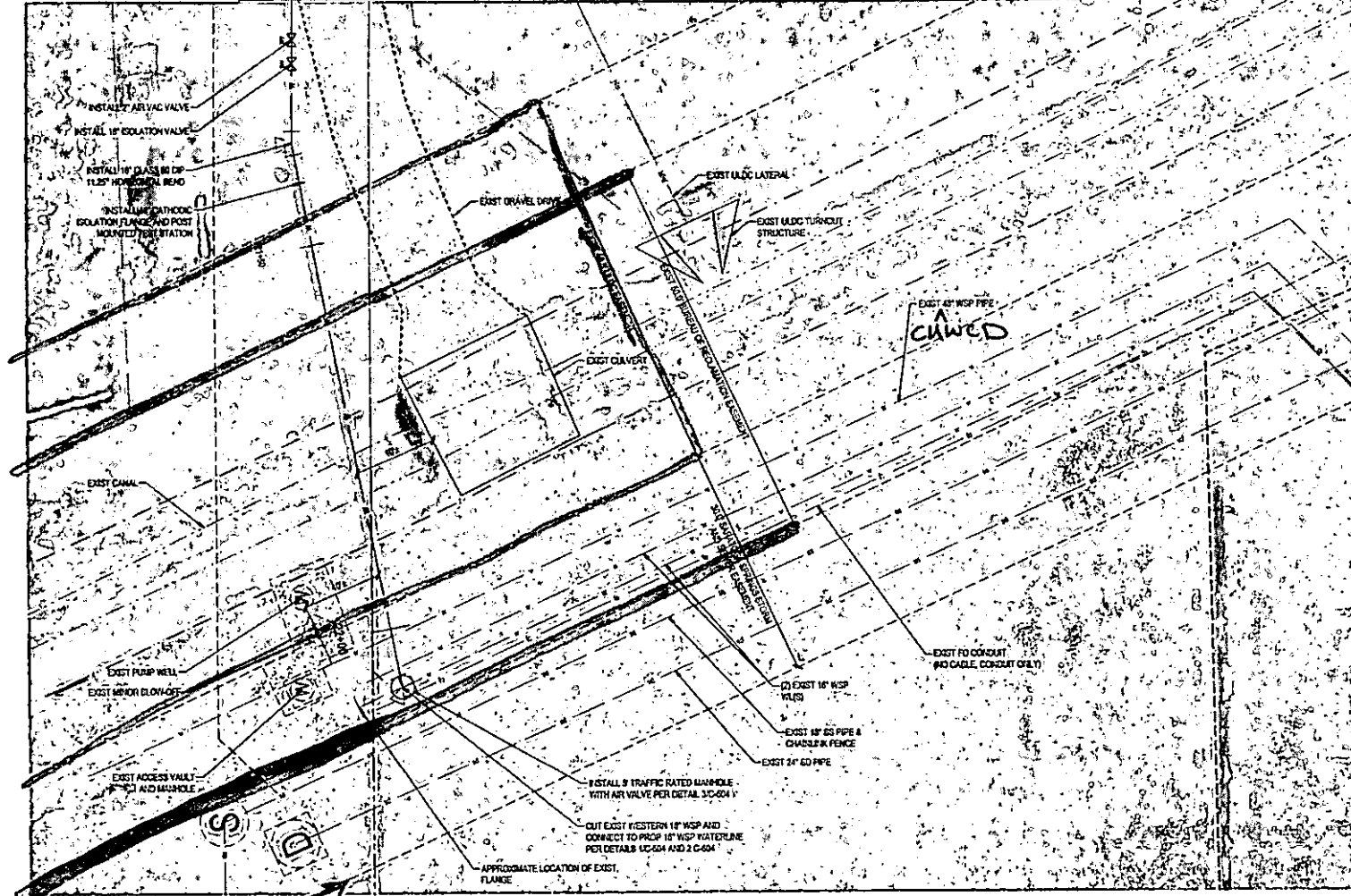

### SOUTH WATER LINE - CUWCD CONNECTION

*JWCD perpetual Easement*

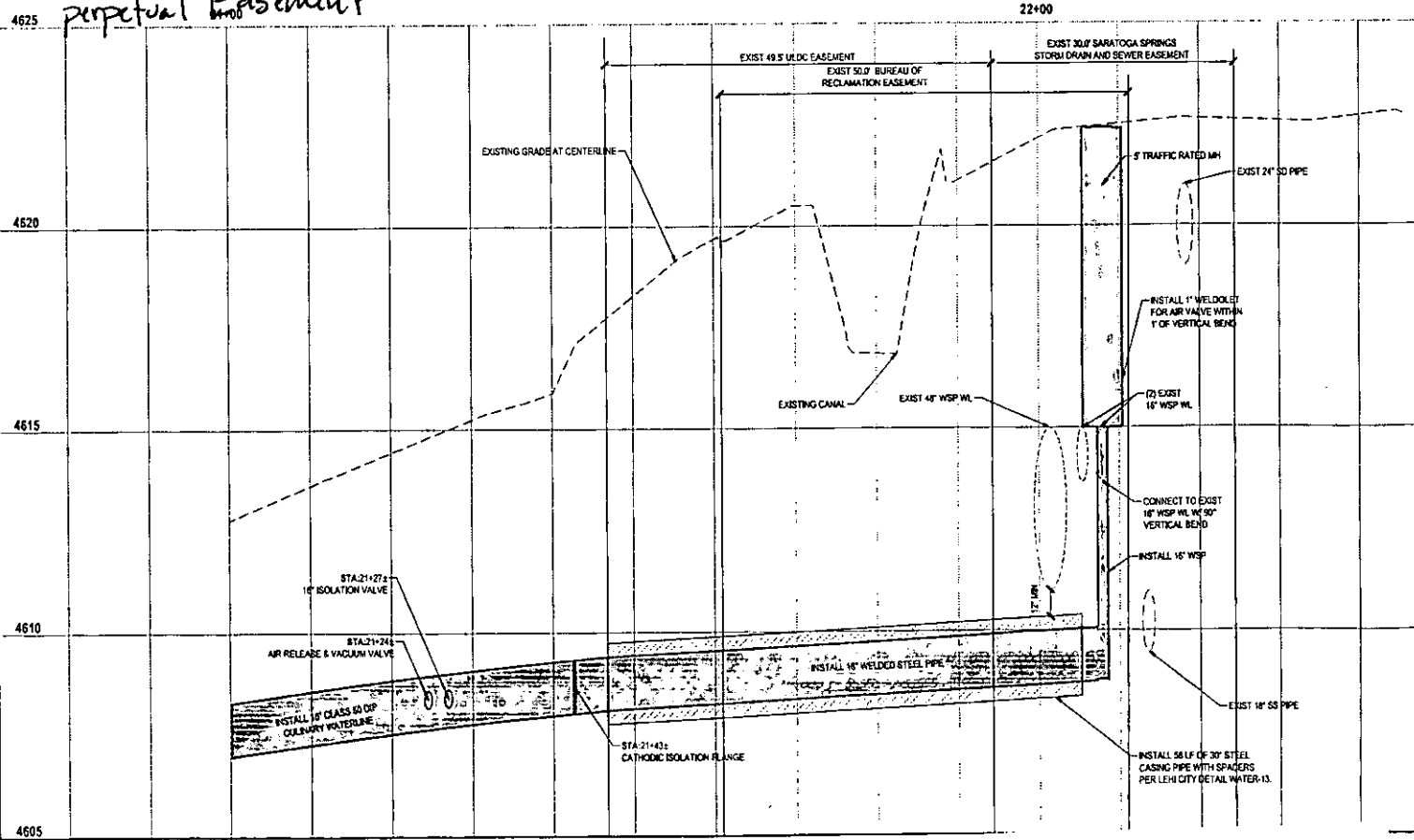

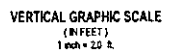
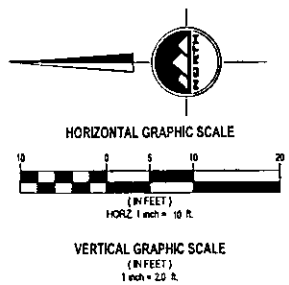
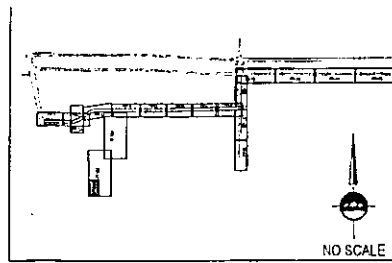
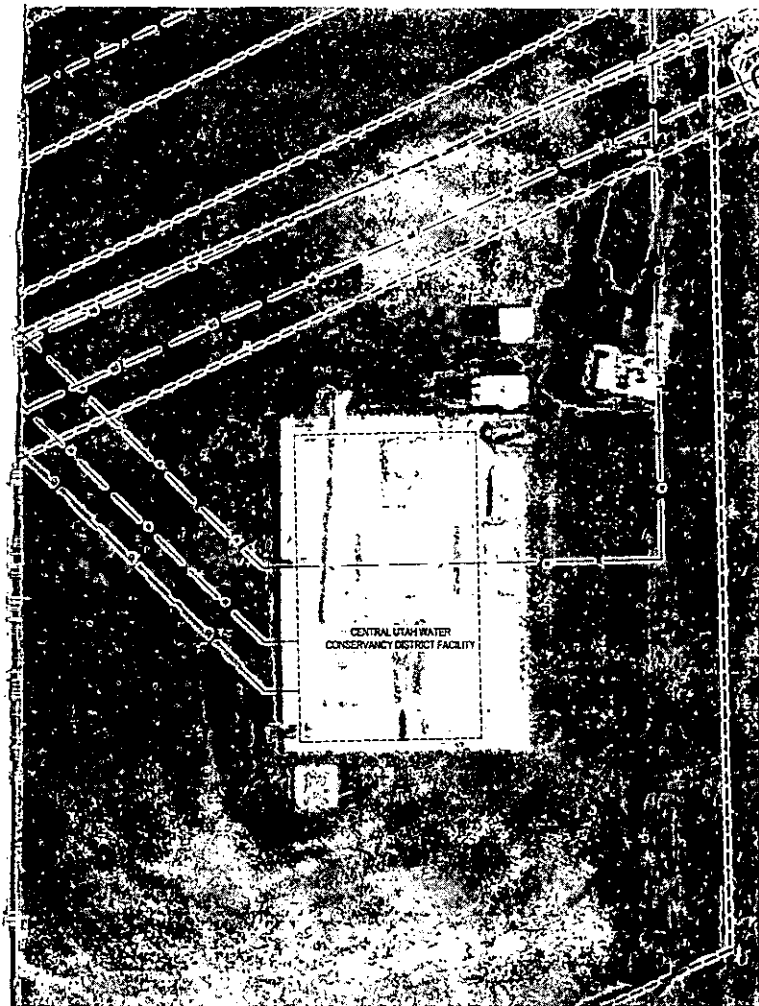

- NOTES**
1. SEE SHEET C504 FOR CONNECTION DETAILS

ENT 25944:2016 PG 19 of 25

**ENSIGN**  
THE STANDARD IN ENGINEERING

**SALT LAKE CITY**  
45 W. 10000 S., Suite 500  
Sandy, UT 84070  
Phone: 801.255.0529

**LAYTON**  
Phone: 801.547.1100

**TOOELE**  
Phone: 435.843.3590

**CEDAR CITY**  
Phone: 435.865.1453

**RICHFIELD**  
Phone: 435.896.2983

[WWW.ENSIGNENG.COM](http://WWW.ENSIGNENG.COM)

FOR:  
GARDNER COMPANY  
90 SOUTH 400 WEST  
SALT LAKE CITY, UTAH 84101

CONTACT:  
MARK MURDOCK  
PHONE: 801-915-1822

HARDMAN WAY

LEHI CITY, UTAH

4625		
4620		
4615		
4610		
4605		

- CONNECTION NOTES**
1. NOTIFICATION MUST BE GIVEN AT LEAST 24 HOURS PRIOR TO THE BEGINNING OF CONSTRUCTION WORK AND RE-NOTIFICATION OF RE-COMMENCEMENT OF WORK FOLLOWING ANY CESSATION OF WORK FOR MORE THAN 4 (FOUR) DAYS MUST BE GIVEN. CALL TODD ADAMS AND THE ULDC WATER MASTER. FAILURE TO DO SO WILL RESULT IN A \$5,000 FINE.
  2. NOTIFY ULDC O&M MANAGER BILL PEATROSS 48 HOURS PRIOR TO ANY WORK ON EXISTING 18" WSP.
  3. JWCD INSPECTOR, GORDON BATT, 801-330-6507, MUST BE CONTACTED 48 HOURS PRIOR TO ANY CONSTRUCTION WITHIN THE EASEMENT AND MUST BE PRESENT ANY TIME THE 48" PIPELINE IS EXPOSED.
  4. CONTACT INFORMATION FOR FCE, ULDC, AND JWCD:
    - 4.1. TODD ADAMS, FCE, 801-754-0205
    - 4.2. VINCE HOGGE, P.E., FCE, 801-754-0205
    - 4.3. JEFF MCMAILLIN, PRESIDENT, ULDC, 801-941-3323
    - 4.4. KIM EVANS, WATER MASTER, SARATOGA CANAL, 801-941-4098
    - 4.5. BILL PEATROSS, O&M MANAGER, ULDC, 425-923-4147
    - 4.6. GORDON BATT, 801-330-6507, JWCD
  5. ANY CHANGES IN DESIGN DRAWINGS AFTER THE EMBANKMENT AGREEMENT HAS BEEN EXECUTED MUST BE REVIEWED AND ACCEPTED BY FRANSON CIVIL ENGINEERS AND UTAH LAKE DISTRIBUTING COMPANY.
  7. ALL CONSTRUCTION WITHIN THE CANAL CORRIDOR MUST BE COMPLETED TO ULDC STANDARDS.
  8. WORK CANNOT INTERFERE WITH DELIVERY OF WATER. CONSTRUCTION WITHIN ULDC CORRIDORS THAT IMPACTS THE CANAL OR THE OPERATION AND MAINTENANCE ROAD (O&M ROAD) MUST BE COMPLETED BETWEEN OCTOBER 15 AND APRIL 1.
  9. IF DISTURBED, THE CANAL OPERATION & MAINTENANCE ROAD (O&M ROAD) MUST BE RETURNED TO PRE-CONSTRUCTION STATE OR BETTER, FOLLOWING CONSTRUCTION. THE O&M ROAD MUST BE AVAILABLE FOR USE BY ULDC PERSONNEL NO LATER THAN APRIL 1.
  10. STORM WATER RUNOFF ENITERS CANAL DURING STORM EVENTS OR AT OTHER UNEXPECTED TIMES. IT IS THE RESPONSIBILITY OF THE CONTRACTOR TO PROTECT THE WORK SITE.
  11. CANAL FLOOR AND EMBANKMENT MATERIAL REMOVED FOR EXCAVATION SHALL BE REPLACED WITH 12-INCH MINIMUM THICKNESS OF 10% CAIRED, PERMEABILITY CLAY MATERIAL IN 6-INCH MAXIMUM LIFTS.
  12. THE TRENCH THROUGH THE CANAL MAY BE CUT AS LITTLE AS 1/8" HORIZONTAL TO 1" VERTICAL TO MINIMIZE THE AMOUNT OF LINER THAT NEEDS TO BE INSTALLED. IT IS THE RESPONSIBILITY OF THE APPLICANT TO VERIFY THAT COMPACTION WILL NOT BE AFFECTED.
  13. EMBANKMENT MATERIAL SHALL BE COMPACTED TO A MINIMUM OF 92% MODIFIED PROCTOR DENSITY. NATIVE MATERIAL MAY BE USED.
  14. COMPACTION TEST RESULTS MUST BE SUBMITTED TO FRANSON CIVIL ENGINEERS. ALL FALLED MATERIAL SHALL BE REMOVED AND COMPACTED TO SPECIFICATIONS. TESTING MUST BE PERFORMED BY A LICENSED SOILS LAB.
  15. CANAL EMBANKMENT SHALL BE SHAPED TO MATCH THE EXISTING CANAL PRISM.
  16. CONTRACTOR TO NOTIFY TODD ADAMS OF FRANSON CIVIL ENGINEERS WHEN FLOWABLE FILL IS PLACED. ACCEPTANCE OF FLOWABLE FILL MUST BE GRANTED BY FRANSON CIVIL ENGINEERS BEFORE BACKFILLING.
  17. CUT BACK EXISTING 18" WSP TO PROVIDE CANAL CROSSING ALIGNMENT AS SHOWN.
  18. WSP LININGS AND COATINGS SHALL MEET ULDC APPROVAL. EXPOSED METAL AT FIELD-WELDED JOINTS SHALL BE PROTECTED (CANASA SHEATH SLEEVE OR EQUAL IS ACCEPTABLE).
  19. PROVIDE CATHODIC PROTECTION ISOLATION AT FLANGE CONNECTION BETWEEN DP AND WSP (TYPE E FLANGE ISOLATION KIT FOR CATHODIC PROTECTION). PROVIDE POST-MOUNTED TEST STATION TO TEST ISOLATION AT FLANGE. SUBMIT ISOLATION KIT FOR APPROVAL BY CENTRAL UTAH WATER CONSERVANCY DISTRICT (CWD) PRIOR TO INSTALLATION.
  20. WAX TAPE CONNECTION FLANGE PRIOR TO BURIAL.
  21. THRU-BOLT RESTRAINED JOINTS OR WELDED-STEEL PIPE (WSP) ARE REQUIRED WITHIN THE ULDC EASEMENT. NO MECHANICAL JOINTS ARE ALLOWED WITHIN THE ULDC EASEMENT.
  22. A 12" MINIMUM SEPARATION BETWEEN TOP OF CASING AND BOTTOM OF THE EXIST. 48" ULDC PIPELINE MUST BE FIELD CONFIRMED BY DISTRICT INSPECTOR PRIOR TO BACKFILL.
  23. PRESSURE TEST AND BAC-T RESULTS APPROVAL REQUIRED BY ULDC AND LEHI CITY PRIOR TO FINAL ACCEPTANCE AND INITIATION OF SERVICE.



DATE	REVISED	BY
1/24/2016	NO REVISIONS	JKF

PLAN AND PROFILE

PROJECT NUMBER: 6302B  
PROJECT DATE: 1/26/16  
DRAWN BY: DJW  
CHECKED BY: JKF  
PROJECT MANAGER: JKF

PP-18

Exhibit B.2

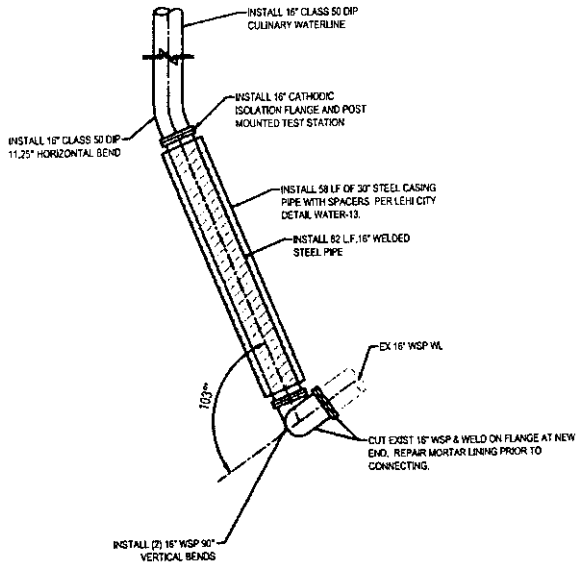

1 WL CONNECTION PLAN VIEW

SCALE: NONE

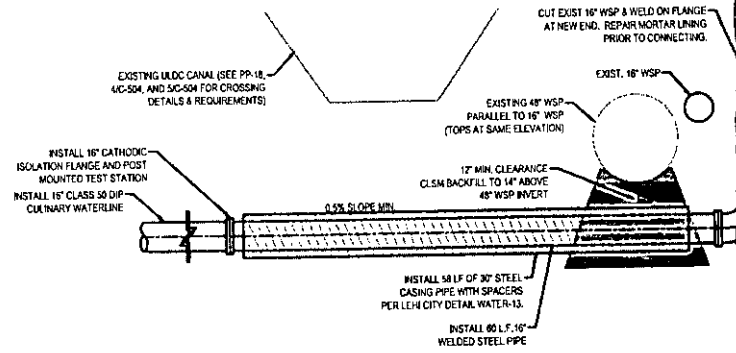

NOTES:

- CARRIER PIPE SHALL BE 16" WELDED STEEL PIPE, WITH A DIELECTRIC TAPE WRAP (POLYKEN OR EQUAL), CEMENT MORTAR LINING (0.31" THICK), AND CEMENT MORTAR COATING (1.00" THICK). FLANGES SHALL BE BOLTED WITH STAINLESS STEEL BOLTS, AND SHALL BE WRAPPED WITH WAX TAPE PRIOR TO BACKFILL.

2 WL CONNECTION SECTION VIEW  
CL OF PIPE

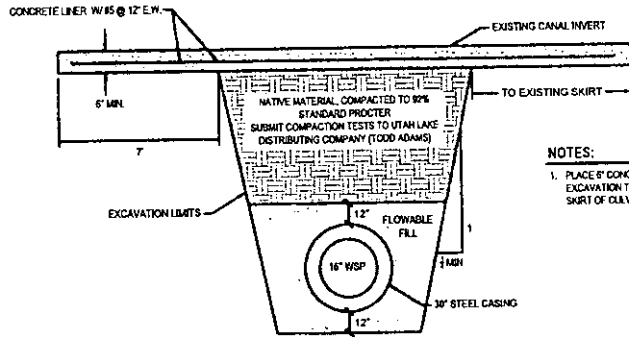

NOTES:

- PLACE 6" CONCRETE LINER 7' PAST LIMITS OF EXCAVATION TO THE NORTH. EXTEND LINER TO SKIRT OF CULVERT TO THE SOUTH.

4 ULDC CANAL SECTION

Scale: NTS

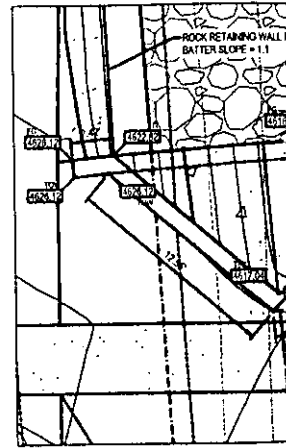

6 NORTH CULVERT

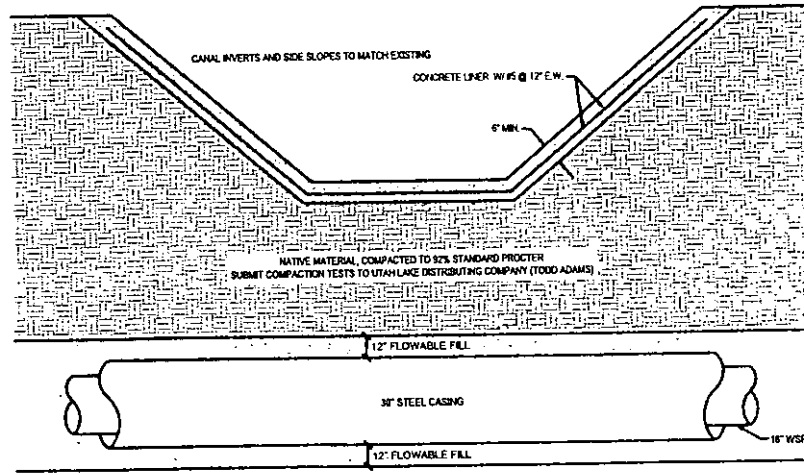

5 ULDC CANAL SECTION

Scale: NTS

**SALT LAKE CITY**  
45 W. 10000 S., Suite 500  
Sandy, UT 84070  
Phone: 801.255.0529

**LAYTON**  
Phone: 801.547.1100

**TOOELE**  
Phone: 435.843.3590

**CEDAR CITY**  
Phone: 435.865.1453

**RICHFIELD**  
Phone: 435.896.2983

WWW.ENSIGNENG.COM

FOR:  
GARDNER COMPANY  
30 SOUTH 400 WEST  
SALT LAKE CITY, UTAH 84101  
CONTACT:  
MARK MURDOCK  
PHONE: 801-915-1822

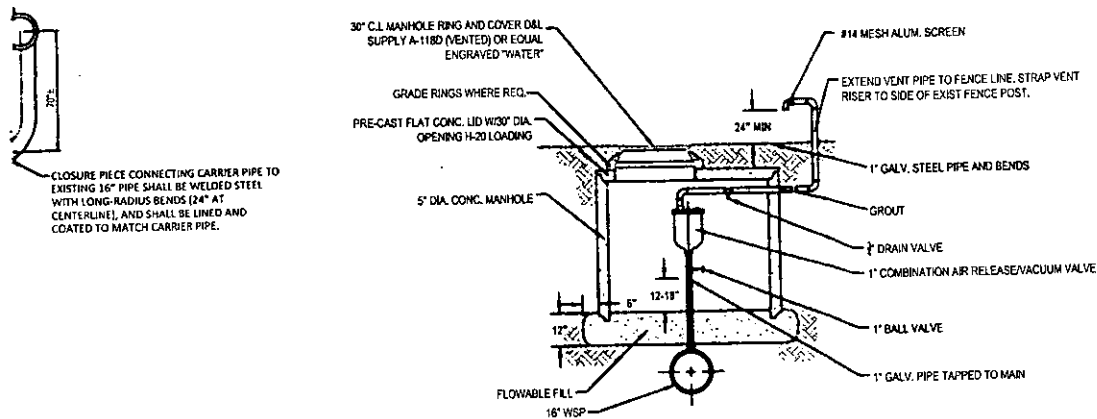

**3 AIR RELEASE VALVE AND VAULT** SCALE: NONE

SCALE: NONE

ENT 25944:2016 PG 21 of 25

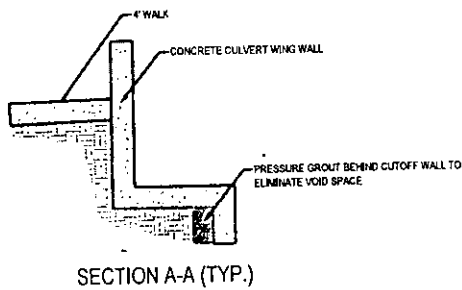
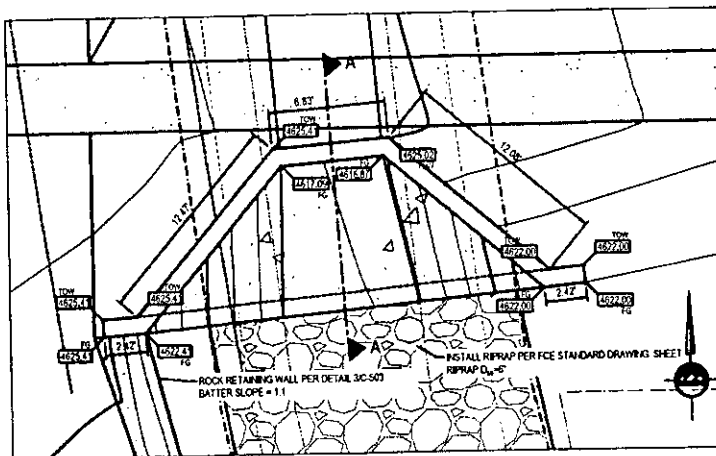
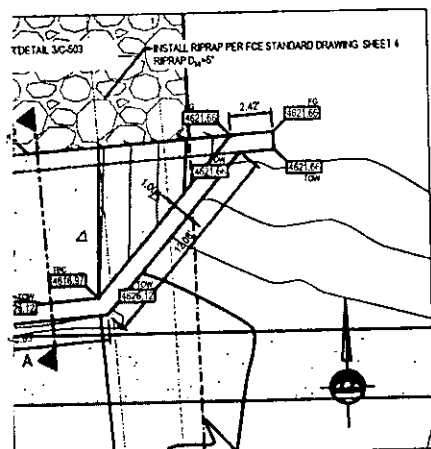

**WING WALL DETAIL** SCALE: 1" = 5.0'

**7 SOUTH CULVERT WING WALL DETAIL** SCALE: 1" = 5.0'

HARDMAN WAY

LEHI CITY, UTAH



NO.	DATE	REVISION	BY
1	02-20-2016	ISSUE FOR BIDDING	JKF

DETAILS SHEET

PROJECT NUMBER: 63033  
PRINT DATE: 1/26/16  
DRAWN BY: DJW  
CHECKED BY: JKF  
PROJECT MANAGER: JKF

**C-504**

Exhibit B.2

SEE NOTE 2 BELOW FOR SIDEWALK / ROAD BASE THICKNESS

SEE NOTE 2 BELOW FOR SIDEWALK / ROAD BASE THICKNESS

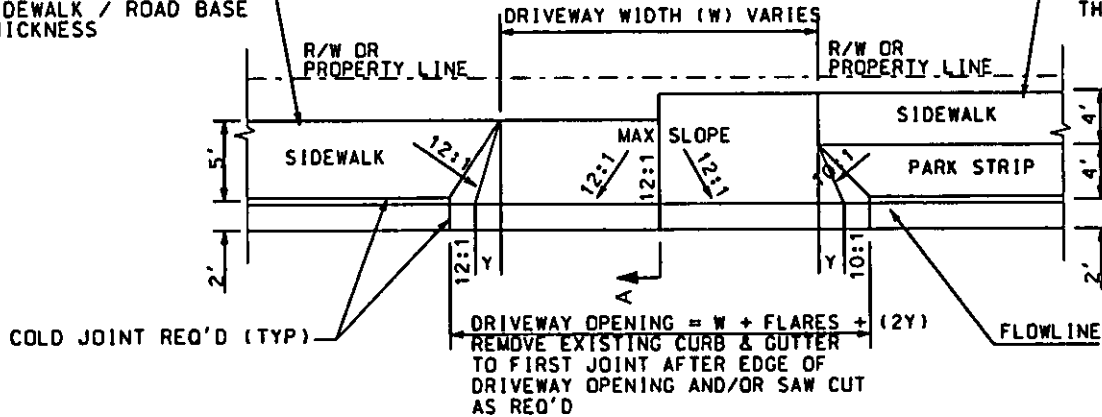

PLAN VIEW

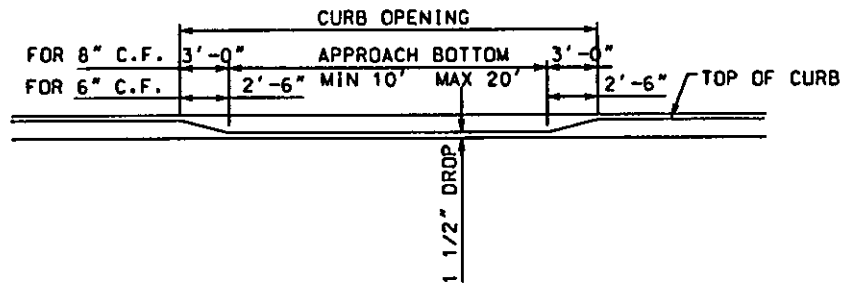

ELEVATION

ENT 25944:2016 PG 22 of 25

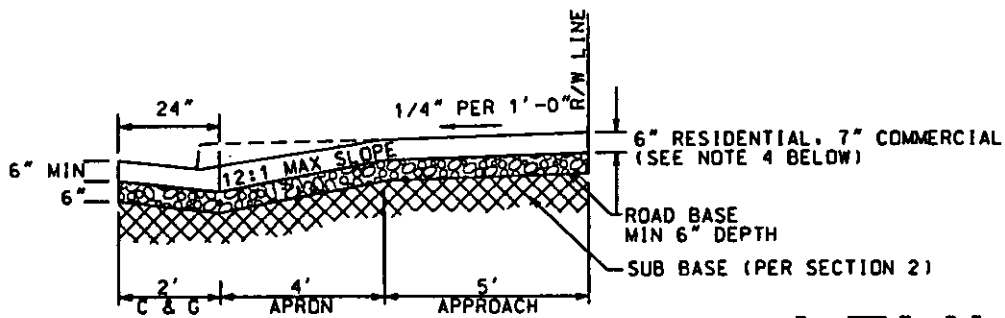

SECTION A-A

GENERAL NOTES:

1. ALL PROPOSED DRIVEWAY PLACEMENT SHOULD BE INSPECTED PRIOR TO POURING OF CONCRETE.
2. SIDEWALK & ROAD BASE THICKNESS SHALL EACH BE 4" EXCEPT WITHIN RESIDENTIAL SUBDIVISIONS WHERE DRIVEWAYS ARE EXPECTED TO BE LOCATED 70 FEET OR LESS APART. IN WHICH SIDEWALK & ROAD BASE THICKNESS SHALL EACH BE 6".
3. IN THE EVENT THAT SIDEWALKS ARE INSTALLED PRIOR TO THE INSTALLATION OF DRIVE APPROACHES, AND THEY ARE NOT CONSTRUCTED TO MEET THE STANDARDS ABOVE, ALL NON-COMPLIANT SIDEWALK SECTIONS SHALL BE REMOVED & REPLACED AS PART OF THE DRIVE APPROACH CONSTRUCTION.
4. MESH, REBAR AND/OR A THICKER CONCRETE AND ROAD BASE SECTION MAY BE REQUIRED BASED UPON ANTICIPATED TRAFFIC LOADS.



STANDARD DETAIL  
FLARED DRIVE  
APPROACH

## EXHIBIT C

## GUIDELINES FOR ENCROACHMENT

A. Surface structures that may be constructed within the District's Easement/Right-of-Way, but only upon the prior written consent of the District, include asphalt roadway, with no utilities within roadway; non-reinforced parking lot, curb, gutter, sidewalk, walkway and driveway; and non-masonry fence with gated opening. However, where the District's facilities or pipeline(s) has specific maximum and minimum cover designations, the special requirements for structures crossing over the pipeline(s) shall be obtained from the District for the maximum allowable external loading or minimum cover. It is understood that all surface structures shall be analyzed and considered by the District on an individual basis.

B. Structures that may not be constructed in, on, over, across or along the District's Easement/Right-of-Way include but are not limited to permanent structures such as footings, foundations, masonry block walls, buildings, garages, decks, carports, trailers, swimming pools and athletic courts, as designated and characterized by the District.

C. No trees are allowed within the Easement/Right-of-Way.

D. All changes in ground surfaces within the Easement/Right-of-Way are considered encroaching structures. Earthfills and cuts on adjacent property shall not encroach onto the Easement/Right-of-Way without the prior written consent of the District.

E. Existing gravity drainage of the Easement/Right-of-Way shall be maintained. No new concentration of surface or subsurface drainage may be directed onto, under or across the Easement/Right-of-Way without adequate provision for removal of drainage water or adequate protection of the Easement/Right-of-Way.

F. Prior to any construction within the Easement/Right-of-Way, an excavation must be made to determine the location of existing District facilities and pipeline(s). The excavation shall be made by or in the presence of the District, at the City's expense.

G. All construction activities within the Easement/Right-of-Way shall be limited to construction of the Encroachment Improvements previously approved by the District, and the Encroachment Improvements shall be constructed strictly in accordance with the plans and specifications previously approved by the District.

H. The ground surfaces within the Easement/Right-of-Way shall be restored to the condition, elevation and contour which existed prior to construction or as shown on the plans, drawings, guidelines and/or maps set forth in Exhibits B.1 and B.2.

I. The City shall notify the District upon completion of construction and shall, at its expense, provide the District with one (1) copy of as-built drawings showing actual Encroachment Improvements within the Easement/Right-of-Way.

J. Following completion of construction of the Encroachment Improvements, and except in case of emergency repairs, the City shall give the District at least ten (10) days written notice before entering upon the Easement/Right-of-Way for the purpose of accessing, maintaining, inspecting, repairing, or removing the Encroachment Improvements.

K. If unusual conditions are proposed for the Encroachment Improvements or unusual field conditions within the Easement/Right-of-Way are encountered, as designated and characterized by the District, the District may, at its discretion, impose conditions or requirements which are different from or more stringent than those prescribed in these Guidelines.



L. All backfill material within the Easement/Right-of-Way shall be compacted to ninety percent (90%) of maximum density, unless otherwise allowed or required by the District. Mechanical compaction shall not be allowed within six inches (6") of any of the District's facilities and pipeline(s). Mechanical compaction using heavy equipment, as designated and characterized by the District, will not be allowed over District facilities and pipeline(s) or within eighteen inches (18") horizontally.

M. Backfilling of any excavation or around any facilities or pipeline(s) within the Easement/Right-of-Way shall be compacted in layers not exceeding six inches (6") thick to the following requirements: (1) cohesive soils to 90 percent (90%) maximum density specified by ASTM Part 19, D-698, method A; (2) noncohesive soils to 70 percent (70%) relative density specified by ANSI/ASTM Part 19, D-2049, par. 7.1.2, wet method.

N. To enable the District to locate non-metallic Encroachment Improvements below ground level, the City shall install a "locator wire" as required by District specifications.

O. The City shall notify the District at least seventy-two (72) hours in advance of commencing initial construction of the Encroachment Improvements in order to permit inspection by the District.

P. No encroachment shall involve the use or storage of hazardous material(s), as designated and characterized by the District.