

**DAYBREAK VILLAGE 7 PLAT 1 SUBDIVISION  
AMENDING LOT 100 OF THE DAYBREAK VILLAGE 7 SUBDIVISION  
AMENDED AMENDING LOT 100 OF THE KENNECOTT DAYBREAK  
VILLAGE 7 SUBDIVISION AMENDING LOTS V7 AND T6 OF THE  
KENNECOTT MASTER SUBDIVISION #1 AMENDED**

Located in the Southwest quarter of Section 23,  
T3S, R2W, Salt Lake Base and Meridian

Containing 65 Lots	6.469 acres
Containing 1 C-Lots	3.535 acres
Containing 8 P-Lots	41,116 S.F. - 0.944 acres
Containing 8 Public Lanes	1.068 acres
Street Right-of-Way	4.666 acres
(Street Rights-of-Way includes 1.094 acres of park strips which shall be counted as open space towards the calculation of the open space requirement set forth in the Master Development Agreement)	

Total boundary acreage 16.682 acres

**DEVELOPED BY:**

Daybreak Communities  
4700 Daybreak Parkway  
South Jordan, Utah 84009

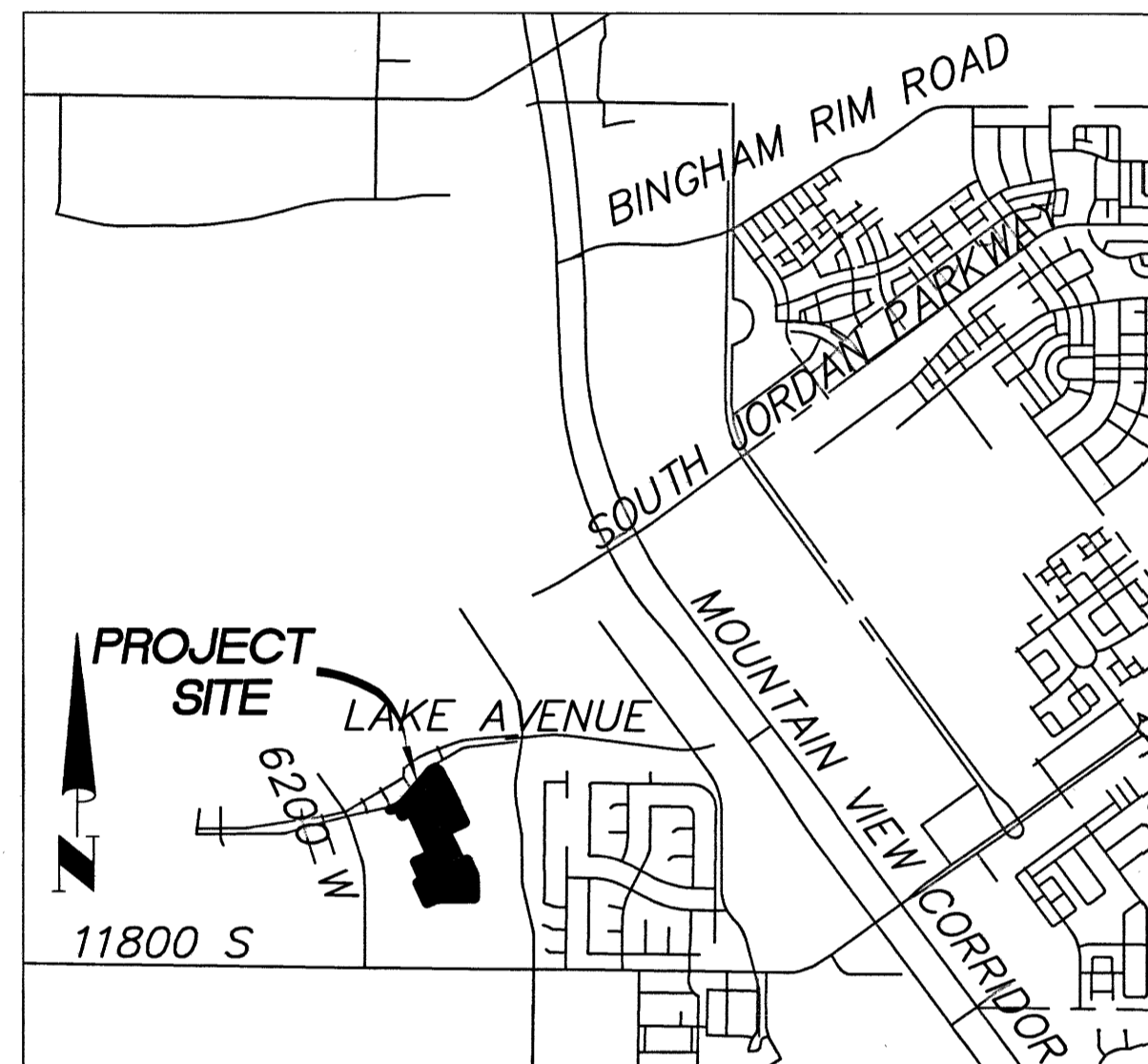

VICINITY MAP

**OWNER'S DEDICATION**

Know all men by these presents that the undersigned owner of the above described tract of land, having caused the same to be subdivided into lots and streets to be hereafter known as:

DAYBREAK VILLAGE 7 PLAT 1 SUBDIVISION  
AMENDING LOT 100 OF THE DAYBREAK VILLAGE 7 SUBDIVISION AMENDED AMENDING LOT 100  
OF THE KENNECOTT DAYBREAK VILLAGE 7 SUBDIVISION AMENDING LOTS V7 AND T6 OF THE  
KENNECOTT MASTER SUBDIVISION #1 AMENDED  
do hereby dedicate for perpetual use of the public all parcels of land and easements as shown on this plat as intended for public use.

In witness whereof I have here unto set my hand this  
16<sup>th</sup> day of OCTOBER, A.D., 2017.

VP Daybreak Operations LLC,  
a Delaware limited liability company

By: Daybreak Communities LLC,  
a Delaware limited liability company  
Its: Project Manager

*Ty K. McCutcheon*  
Ty K. McCutcheon  
President & CEO

**CORPORATE ACKNOWLEDGMENT**

"The Owner's Dedication was acknowledged before me this 16<sup>th</sup> day of October, 2017, by Ty K. McCutcheon as President & CEO for Daybreak Communities LLC, a Delaware limited liability company, the project manager of VP Daybreak Operations LLC, a Delaware limited liability company."

*Annette M. Mabey*  
Annette M. Mabey  
Notary Public

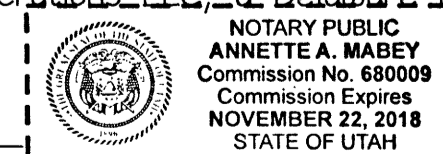

**This map is provided solely for the purpose of assisting in locating the property and Cottonwood Title Insurance Agency, Inc. assumes no liability for variation, if any, with any actual survey.**

**NOTES:**

1. In conjunction with the recordation of this plat for DAYBREAK VILLAGE 7 PLAT 1 SUBDIVISION, there shall also be recorded, with respect to the "tract" described hereon, a document entitled "Supplement to Covenant for Community for Daybreak Submitting Additional Property", and, with respect to the residential lots and certain other lots within this Plat, a document entitled "Supplement to Community Charter for Daybreak Submitting Additional Property" (each, a "Supplement"). The Supplements subject the "tract" described hereon to a document entitled "Covenant for Community for Daybreak" (the "Covenant"), and the residential lots and certain other lots within this Plat to a second document entitled "Community Charter for Daybreak" (the "Charter"). In addition, any non-residential lot(s) may also have recorded against them a "Supplement to Amended and Restated Declaration of Covenants, Conditions and Restrictions for Daybreak Village Submitting Additional Property", which subjects such non-residential lots within this Plat to the "Amended and Restated Declaration of Covenants, Conditions and Restrictions for Daybreak Village" (the "Village Declaration"). This Plat is part of a master-planned community commonly known as "Daybreak" and is subject to the Master Development Agreement recorded on March 26, 2003 as Entry No. 8581557, in Book 8762 beginning on Page 7103 of the Official Records of Salt Lake County (which Master Development Agreement may be amended from time to time) (the "Master Development Agreement").

2. The "tract" subdivided by this Plat is hereby specifically subjected to a reservation by the Owner of (i) all oil, gas, geothermal and mineral rights and interests under or appurtenant to the "tract" subdivided by this Plat, and (ii) all water flowing or located under, within, over, or through the "tract" subdivided by this Plat, including, without limitation, all storm water and reclaimed water. The "tract" subdivided by this Plat is further subject to all easements, restrictions, reservations, rights-of-way, shortages in area, encroachments, or other encumbrances, whether such matters are of record or otherwise enforceable at law or in equity.

3. All areas identified on this Plat as public rights-of-way are intended for public use and are hereby dedicated for the perpetual use of the public pursuant to the Owner's dedication shown hereon. All other areas are not dedicated for public use by this Plat. Lots designated as "O" and "P" are to be dedicated or donated to either: (i) the city or other governmental entity, or (ii) an owners' association for common area use, in a subsequently recorded instrument or an amendment to this Plat. Any easement shown on this Plat that is not specifically referred to as "public" is reserved to Owner or to Owner's designee.

4. The Owner reserves, in favor of Daybreak Water Company, a Utah non-profit corporation, easements over, across and under all streets, public rights-of-way, alleys, "P" lots and "O" lots, and other public use areas, and all public utility and drainage easement areas to install, maintain, repair, and otherwise operate and accomplish all things associated with, a secondary water system providing secondary water to portions of Daybreak.

5. On any lot in this Plat encumbered by a blanket PUD/E easement, Owner reserves the right to relocate and/or more particularly define the location of such easement by Owner recording a notice of such location concerning such lot in the Official Records of Salt Lake County. Owner's relocation or definition of the easement is subject to existing utility's consent.

6. From and after recordation of this plat, any amendment thereto or further subdivision thereof or within therewith shall not be deemed to be an amendment to the Kennecott Master Subdivision #1 referred to hereon. Further subdivision of the Kennecott Master Subdivision #1 is consented to by any owner at any time hereafter purchasing or having an interest in any lots shown on this plat.

7. Certain lots on this Plat may be served by sewer laterals that are less than 11 feet below ground level. In such event the residences on such lots with basements may not have sewer service available to the basements. The owner of any lot in this Plat shall be responsible for verifying the sewer lateral depth serving said lot and shall be responsible for setting the foundation elevation of the residence constructed thereon to a depth sufficient for adequate fall into the respective sewer lateral.

**EASEMENT NOTE:**

Owner certifies that the easements, claims of easements, or encumbrances on the platted property which are shown by public records are shown on this plat based on the title report issued by First American Title Co., Order Number 051-5782924, Amendment No. 6 with an effective date of October 3, 2017.

**HIGH GROUND WATER:**

Many areas in South Jordan City have ground water problems due to high (fluctuating) water table. Approval of this plat does not constitute representation by the City that building at any specified elevation will solve groundwater problems, if any.

**SEWER LATERAL NOTE:**

All lots contained within this Plat are served by private sewer laterals. The owner(s) of a lot in this Plat or any portion of an Alpha Parcel which is served by a sewer lateral which traverses a lot labeled "P" or "O", a public right-of-way, or a PUD/E easement is hereby granted an easement over any through such "P" and/or "O" lots, public rights-of-way and/or PUD/E easements for the purpose of allowing such owner(s) the right to operate, maintain and repair such sewer lateral. Promptly following any construction, repairs or maintenance requiring disturbance of the surface or subsurface of a burdened property, the benefited party shall cause the surface and subsurface of the burdened property to be restored to a condition substantially similar to the condition prior to such disturbance.

**SEWER NOTE:**

"The signature of South Valley Sewer District on this plat does not constitute any guarantee of availability of sanitary sewer service to the property or any approval of sewer lines or facilities. The owner(s) of the property must provide satisfactory plans to the Sewer District for review and approval before connecting to the District's sewer system and will be required to comply with the District's rules and regulations."

**NOTICE:**

Potential purchasers of property described on this plat are advised by South Jordan City to familiarize themselves with all notes, lot information, easements and other pertinent information contained on this plat and also with any Covenants, Conditions and Restrictions ("CCRs") recorded against such property, including those described in note 1 of this plat. Such property may also be subject to the restrictions of the Kennecott Development Standards Matrix ("Matrix") attached to the Kennecott Master Subdivision #1 Plat recorded in Book 2002P commencing at Page 273, in the Salt Lake County Recorder's Office, as it may be amended from time to time. These documents may limit the use of the property and failure to comply with such documents may result in financial losses to the property owner. Purchasers and property owners are responsible to review and to be in compliance with this plat, the CCRs, the Matrix and other recorded documents related to this plat, as currently existing or as may from time to time be changed and/or amended.

**SURVEYOR'S CERTIFICATE**

I, Marshall D. Byrd do hereby certify that I am a Registered Land Surveyor, and that I hold certificate No. 6390728 as prescribed under the laws of the State of Utah. I further certify that by the authority of the owners, I have made a survey of the tract of land shown on this plat and described below and have subdivided said tract of land into lots and streets, hereafter to be known as DAYBREAK VILLAGE 7 PLAT 1 SUBDIVISION and the same has been correctly surveyed and staked on the ground as shown on this plat.

*Marshall D. Byrd*  
Marshall D. Byrd  
Professional Land Surveyor  
Utah Certificate No. 6390728

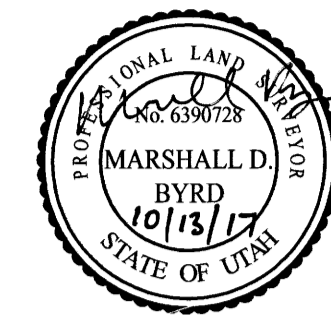

10/13/2017  
Date

**BOUNDARY DESCRIPTION:**

Beginning at a Southerly Corner of Lot 100 of the Daybreak Village 7 Subdivision Amended Amending Lot 100 of the Kennecott Daybreak Village 7 Subdivision Amending Lots V7 and T6 of the Kennecott Master Subdivision #1 Amended said point lies South 89°56'14" West 752.526 feet along the Section Line and North 800.676 feet from the South Quarter Corner of Section 23, Township 3 South, Range 2 West, Salt Lake Base and Meridian and running thence along the Boundary of said Lot 100 the following (3) courses: 1) North 25°00'00" West 266.779 feet; 2) North 65°00'00" East 77.841 feet; 2) North 25°00'00" West 236.000 feet; thence North 65°00'00" East 204.954 feet; thence North 25°00'00" West 472.000 feet; thence North 27°21'26" West 84.180 feet; thence South 62°38'34" West 93.847 feet; thence South 65°00'00" West 16.725 feet; thence North 25°00'00" West 111.321 feet; thence South 62°38'34" West 31.000 feet; thence South 77°49'38" West 71.185 feet to a Northerly Line of said Lot 100 and a point on a 329.000 foot radius tangent curve to the left, (radius bears North 12°10'22" West); thence along said Northerly Line the following (4) courses: 1) along the arc of said curve 216.516 feet through a central angle of 37°42'23"; 2) North 40°07'15" East 430.230 feet to a point on a 200.000 foot radius tangent curve to the right, (radius bears South 49°52'45" East); 3) along the arc of said curve 67.186 feet through a central angle of 19°14'51"; 4) North 59°22'05" East 32.532 feet; thence South 30°37'55" East 49.889 feet; thence North 59°22'05" East 20.000 feet; thence South 30°37'55" East 45.111 feet; thence South 24°42'20" East 95.510 feet; thence North 59°22'05" East 4.526 feet; thence South 30°37'55" East 56.000 feet; thence South 25°00'00" East 180.873 feet; thence South 30°37'55" East 56.000 feet to a Southerly Line of said Lot 100; thence along said Southerly Line the following (11) courses: 1) South 59°22'05" West 5.523 feet; 2) South 25°00'00" East 251.443 feet; 3) South 65°00'00" West 236.000 feet; 4) South 25°00'00" East 406.000 feet; 5) North 65°00'00" East 79.406 feet; 6) South 25°00'00" East 199.448 feet; 7) South 04°28'11" East 29.758 feet; 8) South 00°13'59" East 246.000 feet; 9) South 89°46'01" West 401.238 feet to a point on a 172.000 foot radius tangent curve to the left, (radius bears South 00°13'59" East); 10) along the arc of said curve 74.349 feet through a central angle of 24°46'01"; 11) South 65°00'00" West 93.322 feet to the point of beginning.

Property contains 16.682 acres.



<b>EASEMENT APPROVAL</b> CENTURY LINK: <i>Paul Smith</i> DATE: <u>10-16-17</u> PACIFICORP: <i>Paul Smith</i> DATE: <u>10-16-17</u> QUESTAR GAS: <i>Paul Smith</i> DATE: <u>10-13-17</u> COMCAST: <i>Paul Smith</i> DATE: <u>10-16-17</u>	<b>SALT LAKE VALLEY HEALTH DEPARTMENT</b> APPROVED AS TO FORM THIS <u>26</u> DAY OF <u>October</u> , A.D., 20 <u>17</u> . <i>Rich Sedberry</i> SALT LAKE VALLEY HEALTH DEPARTMENT	<b>SOUTH VALLEY SEWER DISTRICT</b> APPROVED AS TO FORM THIS <u>26</u> DAY OF <u>October</u> , A.D., 20 <u>17</u> . <i>Rich Sedberry</i> GENERAL MANAGER	<b>PLANNING DEPARTMENT</b> APPROVED AS TO FORM THIS <u>28<sup>th</sup></u> DAY OF <u>October</u> , A.D., 20 <u>17</u> . BY THE SOUTH JORDAN PLANNING DEPARTMENT. <i>Gregory R. Schindler</i> CITY PLANNER	<b>SOUTH JORDAN CITY ENGINEER</b> I HEREBY CERTIFY THAT THIS OFFICE HAS EXAMINED THIS PLAT AND IT IS CORRECT IN ACCORDANCE WITH INFORMATION ON FILE IN THIS OFFICE. <u>10/25/17</u> <i>Paul Klavon</i> DATE SOUTH JORDAN CITY ENGINEER	<b>OFFICE OF THE CITY ATTORNEY</b> APPROVED AS TO FORM THIS <u>20<sup>th</sup></u> DAY OF <u>OCTOBER</u> , A.D., 20 <u>17</u> . <i>Paul Klavon</i> ATTORNEY FOR SOUTH JORDAN CITY	<b>SOUTH JORDAN CITY MAYOR</b> APPROVED AS TO FORM THIS <u>25<sup>th</sup></u> DAY OF <u>OCTOBER</u> , A.D., 20 <u>17</u> . <i>Paul Klavon</i> MAYOR	<b>RECORDED # 12654610</b> STATE OF UTAH, COUNTY OF SALT LAKE, RECORDED AND FILED AT THE REQUEST OF: <i>First American Title</i> DATE: <u>11-8-2017</u> TIME: <u>9:28am</u> BOOK: <u>2017</u> PAGE: <u>308</u> FEE \$ <u>\$254.00</u> <i>Edmund Deputy</i> SALT LAKE COUNTY RECORDER
--	--	--	--	---	--	---	---

MATCHLINE SEE SHEET 3

KENNECOTT DAYBREAK VILLAGE 7 SUBDIVISION

KENNECOTT DAYBREAK VILLAGE 7 SUBDIVISION

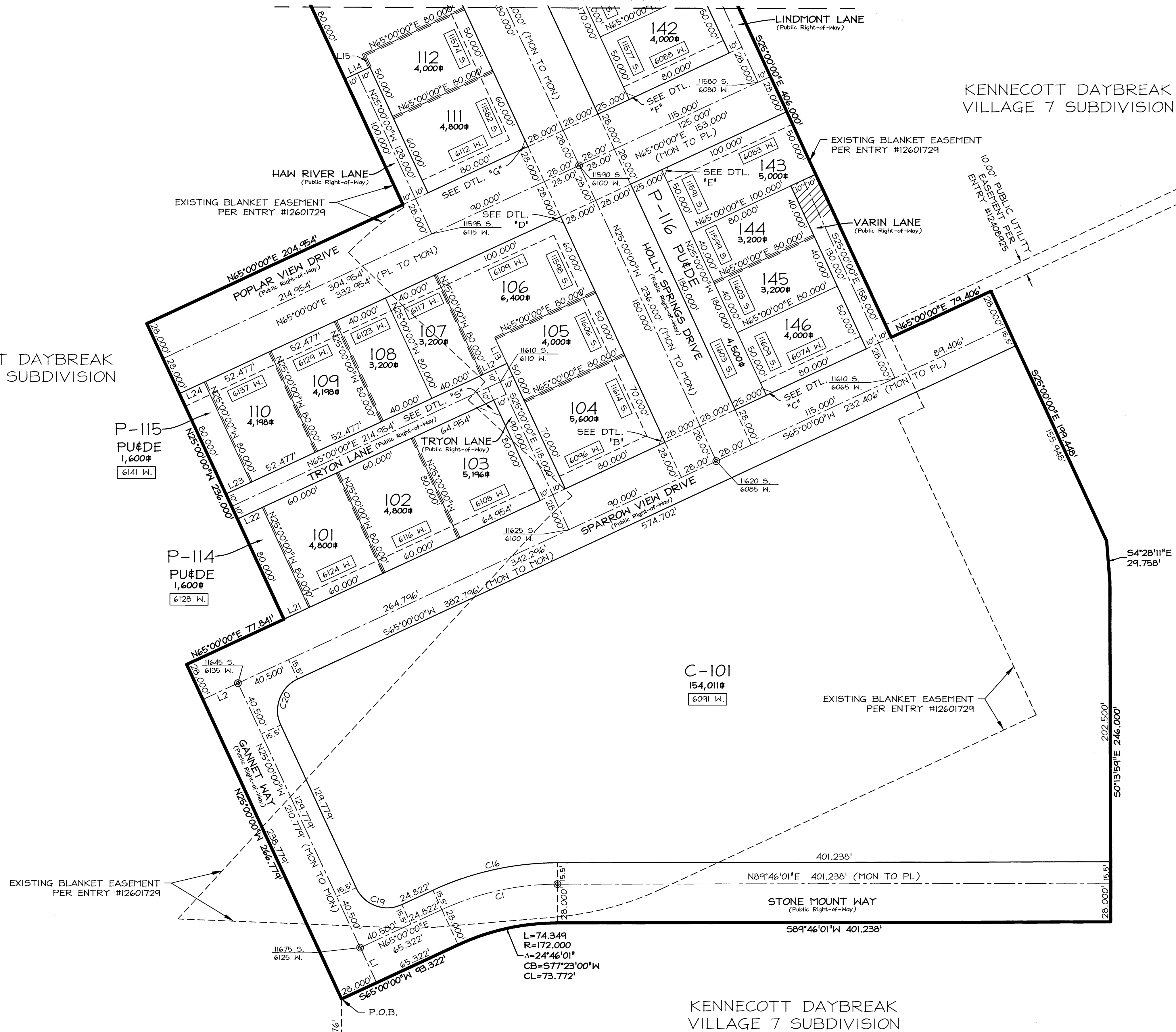

This map is provided solely for the purpose of assisting in locating the property and Cottonwood Title Insurance Agency, Inc. assumes no liability for variation, if any, with any actual survey.

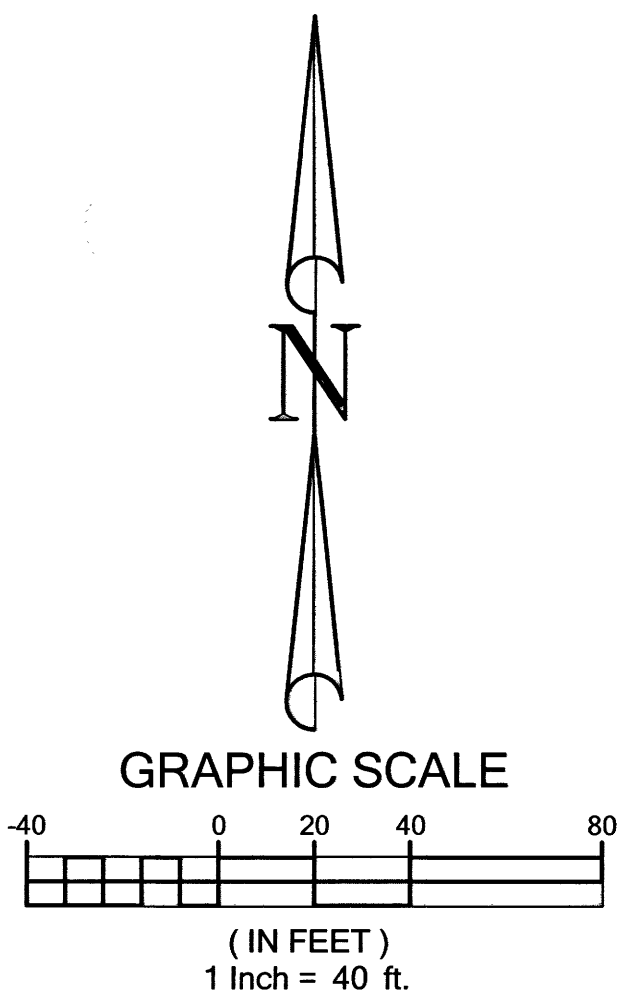

**LEGEND**

- FOUND SALT LAKE COUNTY SECTION CORNER
- PROPOSED STREET MONUMENT
- EXISTING STREET MONUMENT
- ADDRESS WITH ABBREVIATION OF STREET OR LANE
- 1' DRAINAGE EASEMENT PARALLEL TO LOT LINE (UNLESS NOTED OTHERWISE)
- PUBLIC RIGHT-OF-WAY: SOUTH JORDAN CITY WILL NOT PROVIDE SNOW REMOVAL, STREET SWEEPING OR GARBAGE COLLECTION IN THESE AREAS. SNOW REMOVAL AND STREET SWEEPING ARE THE RESPONSIBILITY OF THE ADJACENT LOT OWNERS. GARBAGE CANS MUST BE PLACED ON THE THROUGH PORTION OF THE ADJACENT LANE OR STREET.

NOTE: A PORTION OF THIS SUBDIVISION PLAT IS SUBJECT TO A BLANKET EASEMENT PER ENTRY #12601729 AS RECORDED IN THE SALT LAKE COUNTY RECORDERS OFFICE. ANY PORTION OF SAID EASEMENT LOCATED WITHIN THE BOUNDS OF THIS SUBDIVISION PLAT TO BE SUPERCEDED BY THE EASEMENTS SHOWN HEREON.

Sheet 2 of 6

**PROPERTY CORNERS**  
PROPERTY CORNERS TO BE SET WILL BE REBAR & CAP OR NAILS SET IN THE TOP OF CURB OR ALLEY ON THE EXTENSION OF SIDE LOT LINES.

SOUTHWEST COR. SECTION 23, T3S, R2W, S1B4M  
FND BRASS CAP  
S.L. CO. MONUMENT

SOUTH QUARTER COR. SECTION 23, T3S, R2W, S1B4M  
FND BRASS CAP  
S.L. CO. MONUMENT

BASIS OF BEARING  
S89°56'14"W 2647.894' (MON TO MON)

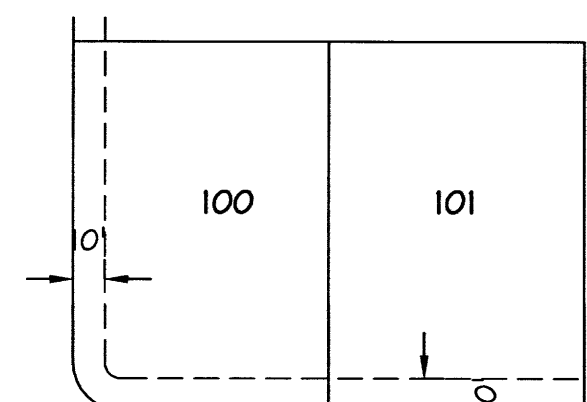

PUBLIC UTILITY EASEMENTS  
TYPICAL  
(UNLESS OTHERWISE NOTED)

DAYBREAK VILLAGE 7 PLAT 1 SUBDIVISION  
AMENDING LOT 100 OF THE DAYBREAK VILLAGE 7 SUBDIVISION AMENDED  
AMENDING LOTS V7 AND T6 OF THE KENNECOTT MASTER SUBDIVISION #1  
AMENDED

Located in the Southwest quarter of Section 23,  
T3S, R2W, Salt Lake Base and Meridian

RECORDED #12654610  
STATE OF UTAH, COUNTY OF SALT LAKE, RECORDED AND FILED AT THE  
REQUEST OF: First American Title  
DATE: 11-8-2017 TIME: 9:35 AM BOOK: 2017 PAGE: 308  
FEE \$ 525.00  
SALT LAKE COUNTY RECORDER

**PERIGEE CONSULTING**  
CIVIL • STRUCTURAL • SURVEY

9089 SOUTH 1300 WEST, SUITE 160 WEST JORDAN, UT 84088  
801.628.6004 TEL 801.590.8511 FAX WWW.PERIGEECIVIL.COM

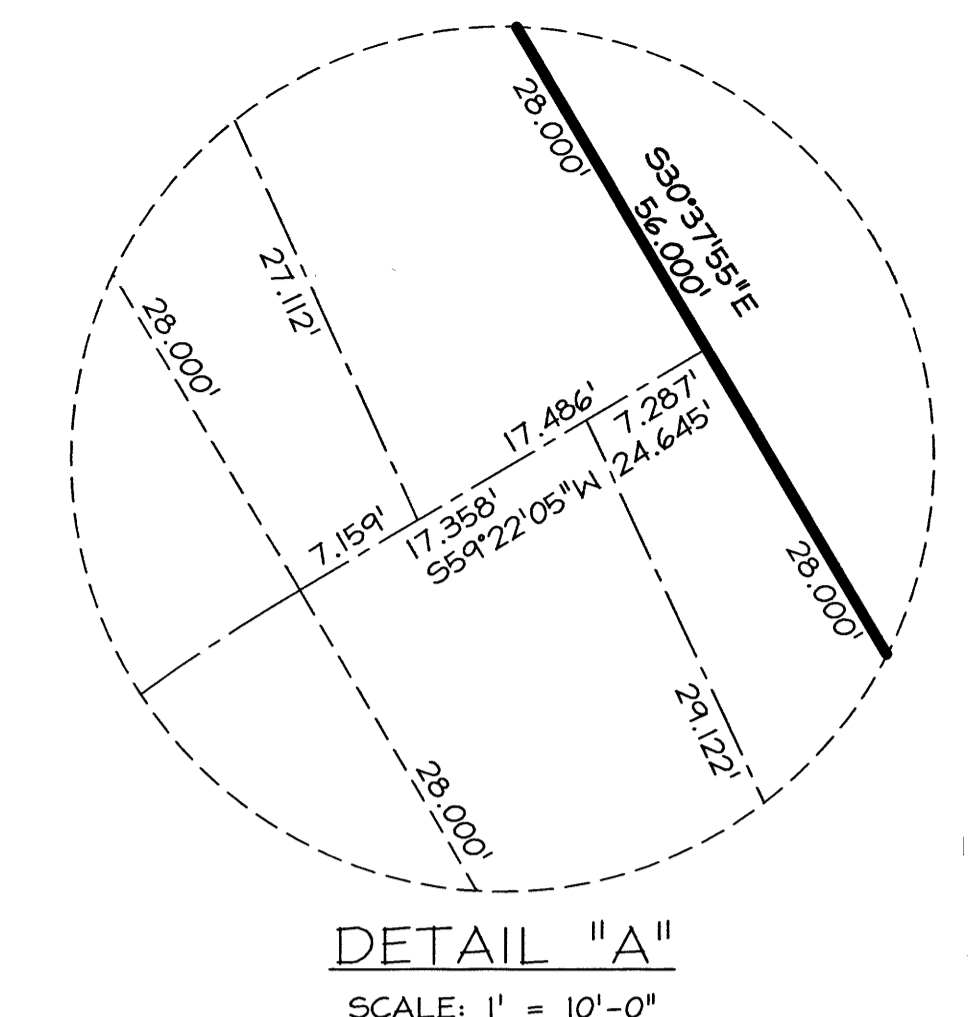
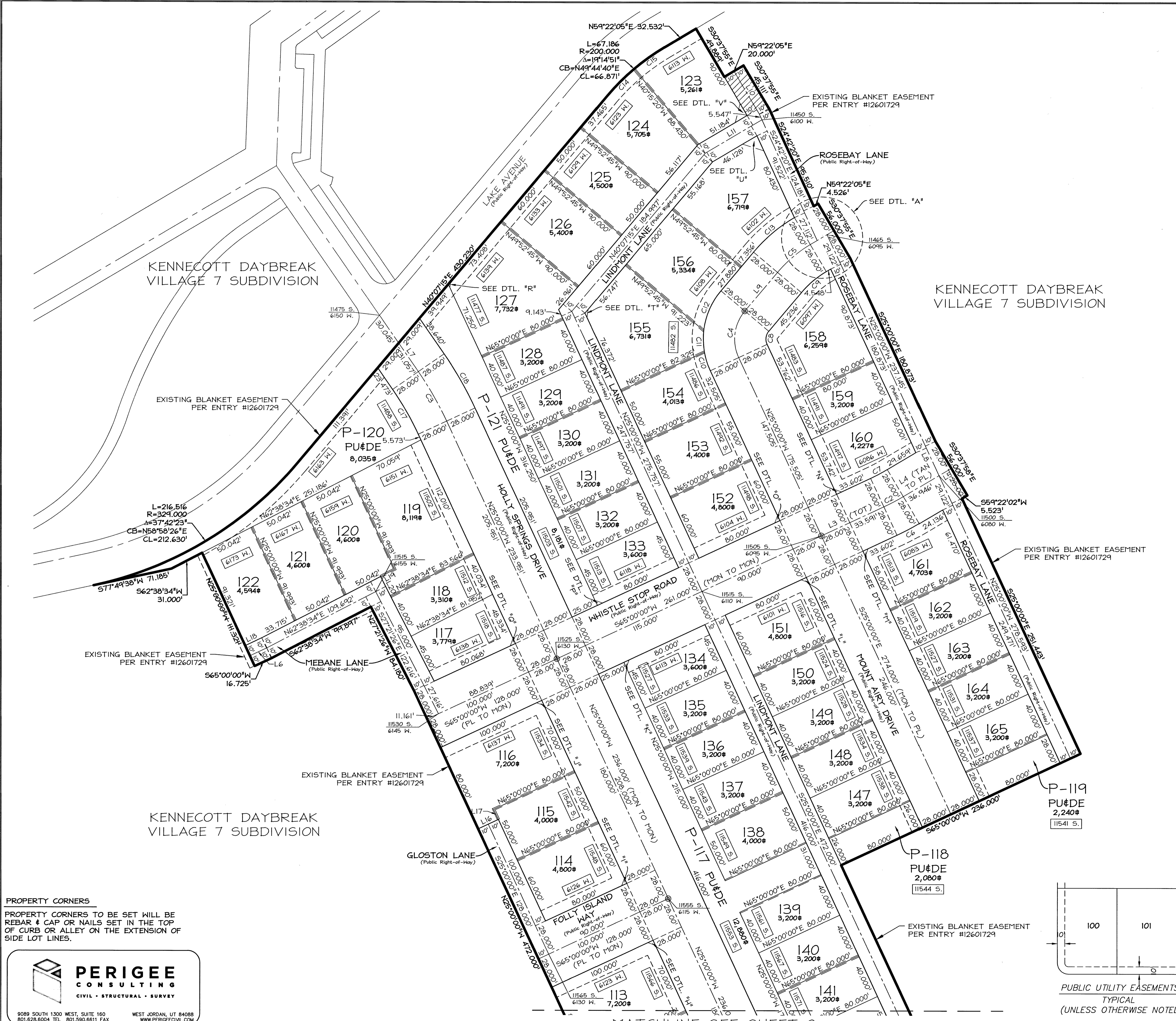

This map is provided solely for the purpose of assisting in locating the property and Cottonwood Title Insurance Agency, Inc. assumes no liability for variation, if any, with any actual survey.

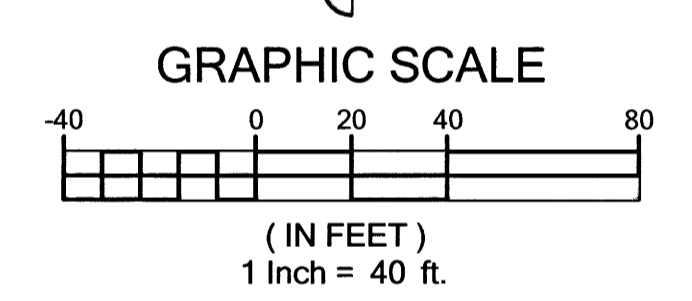
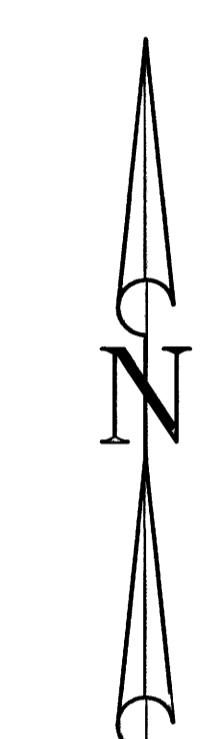

LEGEND

- FOUND SALT LAKE COUNTY SECTION CORNER
- PROPOSED STREET MONUMENT
- EXISTING STREET MONUMENT
- ADDRESS WITH ABBREVIATION OF STREET OR LANE
- 1' DRAINAGE EASEMENT PARALLEL TO LOT LINE (UNLESS NOTED OTHERWISE)
- PUBLIC RIGHT-OF-WAY: SOUTH JORDAN CITY WILL NOT PROVIDE SNOW REMOVAL, STREET SWEEPING OR GARBAGE COLLECTION IN THESE AREAS. SNOW REMOVAL AND STREET SWEEPING ARE THE RESPONSIBILITY OF THE ADJACENT LOT OWNERS. GARBAGE CANS MUST BE PLACED ON THE THROUGH PORTION OF THE ADJACENT LANE OR STREET.

NOTE: A PORTION OF THIS SUBDIVISION PLAT IS SUBJECT TO A BLANKET EASEMENT PER ENTRY #12601729 AS RECORDED IN THE SALT LAKE COUNTY RECORDERS OFFICE. ANY PORTION OF SAID EASEMENT LOCATED WITHIN THE BOUNDS OF THIS SUBDIVISION PLAT TO BE SUPERCEDED BY THE EASEMENTS SHOWN HEREON.

Sheet 3 of 6

DAYBREAK VILLAGE 7 PLAT 1 SUBDIVISION AMENDING LOT 100 OF THE DAYBREAK VILLAGE 7 SUBDIVISION AMENDED AMENDING LOT 100 OF THE KENNECOTT DAYBREAK VILLAGE 7 SUBDIVISION AMENDING LOTS V7 AND T6 OF THE KENNECOTT MASTER SUBDIVISION #1 AMENDED

Located in the Southwest quarter of Section 23, T3S, R2W, Salt Lake Base and Meridian

RECORDED #1265460  
 STATE OF UTAH, COUNTY OF SALT LAKE, RECORDED AND FILED AT THE REQUEST OF: First American Title  
 DATE: 11-8-2017 TIME: 9:35 AM BOOK: 2017P PAGE: 308  
 FEE \$254.00  
 SALT LAKE COUNTY RECORDER

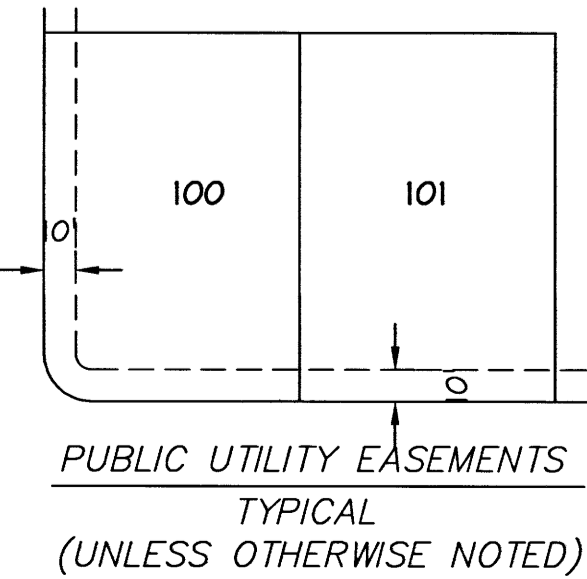

PROPERTY CORNERS  
 PROPERTY CORNERS TO BE SET WILL BE REBAR & CAP OR NAILS SET IN THE TOP OF CURB OR ALLEY ON THE EXTENSION OF SIDE LOT LINES.

**PERIGEE CONSULTING**  
 CIVIL • STRUCTURAL • SURVEY

9089 SOUTH 1300 WEST, SUITE 160 WEST JORDAN, UT 84088  
 801.528.6004 TEL 801.590.8511 FAX WWW.PERIGEECIVIL.COM

MATCHLINE SEE SHEET 2

This map is provided solely for the purpose of assisting in locating the property and Cottonwood Title Insurance Agency, Inc. assumes no liability for variation, if any, with any actual survey.

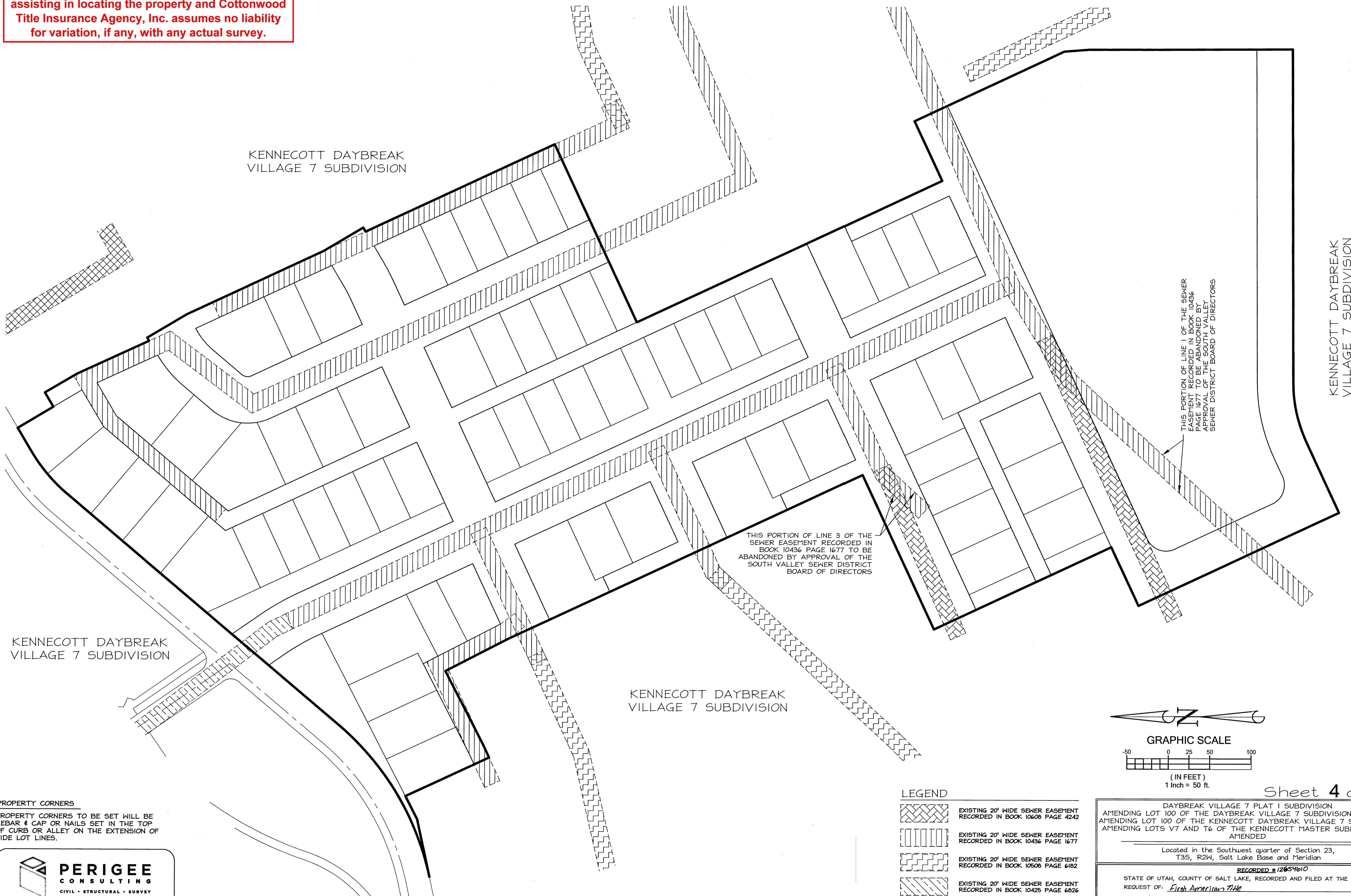

KENNECOTT DAYBREAK VILLAGE 7 SUBDIVISION

KENNECOTT DAYBREAK VILLAGE 7 SUBDIVISION

KENNECOTT DAYBREAK VILLAGE 7 SUBDIVISION

KENNECOTT DAYBREAK VILLAGE 7 SUBDIVISION

THIS PORTION OF LINE 1 OF THE SEWER EASEMENT RECORDED IN BOOK 10436 PAGE 1677 TO BE ABANDONED BY APPROVAL OF THE SOUTH VALLEY SEWER DISTRICT BOARD OF DIRECTORS

THIS PORTION OF LINE 3 OF THE SEWER EASEMENT RECORDED IN BOOK 10436 PAGE 1677 TO BE ABANDONED BY APPROVAL OF THE SOUTH VALLEY SEWER DISTRICT BOARD OF DIRECTORS

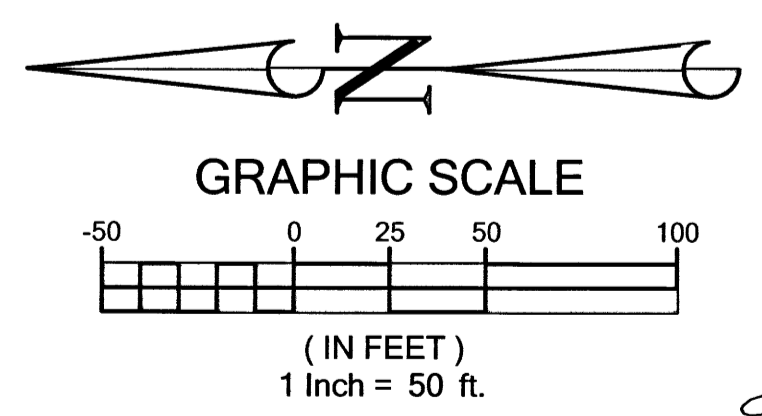

Sheet 4 of 6

**PROPERTY CORNERS**  
PROPERTY CORNERS TO BE SET WILL BE REBAR # CAP OR NAILS SET IN THE TOP OF CURB OR ALLEY ON THE EXTENSION OF SIDE LOT LINES.

**LEGEND**

	EXISTING 20' WIDE SEWER EASEMENT RECORDED IN BOOK 10608 PAGE 4242
	EXISTING 20' WIDE SEWER EASEMENT RECORDED IN BOOK 10436 PAGE 1677
	EXISTING 20' WIDE SEWER EASEMENT RECORDED IN BOOK 10508 PAGE 6182
	EXISTING 20' WIDE SEWER EASEMENT RECORDED IN BOOK 10425 PAGE 6826
	EXISTING 20' WIDE SEWER EASEMENT RECORDED IN BOOK 10475 PAGE 8071

DAYBREAK VILLAGE 7 PLAT 1 SUBDIVISION  
AMENDING LOT 100 OF THE DAYBREAK VILLAGE 7 SUBDIVISION AMENDED  
AMENDING LOTS V7 AND T6 OF THE KENNECOTT MASTER SUBDIVISION #1  
AMENDED

Located in the Southwest quarter of Section 23,  
T3S, R2W, Salt Lake Base and Meridian

RECORDED # 12654610

STATE OF UTAH, COUNTY OF SALT LAKE, RECORDED AND FILED AT THE  
REQUEST OF: First American Title

DATE: 11-8-2017 TIME: 9:35 AM BOOK: 2017P PAGE: 308

FEE \$ \$254.00

[Signature] Deputy  
SALT LAKE COUNTY RECORDER

**PERIGEE CONSULTING**  
CIVIL • STRUCTURAL • SURVEY

9089 SOUTH 1300 WEST, SUITE 160 WEST JORDAN, UT 84088  
801.628.6004 TEL. 801.590.6511 FAX WWW.PERIGEECIVIL.COM

**SIDEWALK EASEMENTS**  
 DETAILS "B" THROUGH "R" - SIDEWALK EASEMENTS FOR  
 HANDICAP RAMP TO BE MAINTAINED BY SOUTH JORDAN CITY

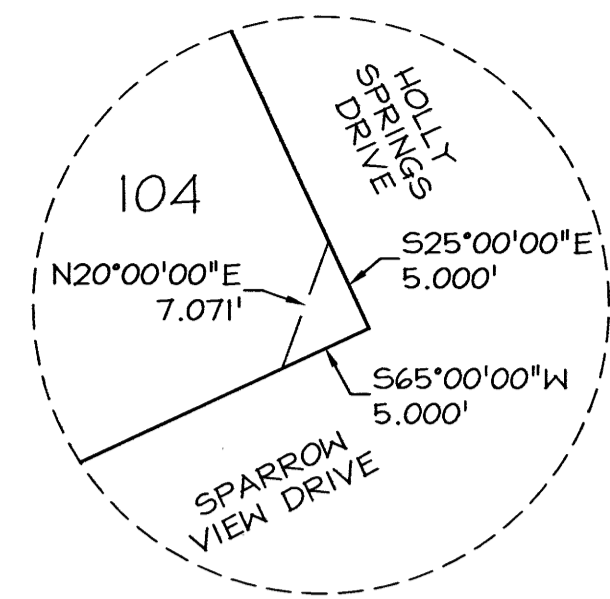

DETAIL "B"  
N.T.S.

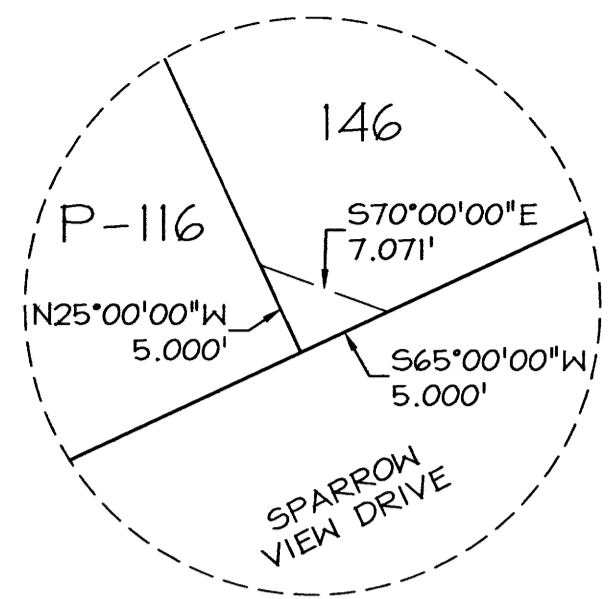

DETAIL "C"  
N.T.S.

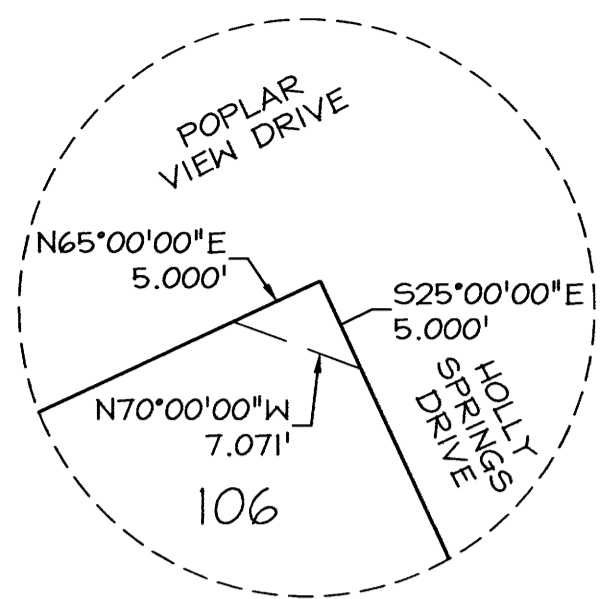

DETAIL "D"  
N.T.S.

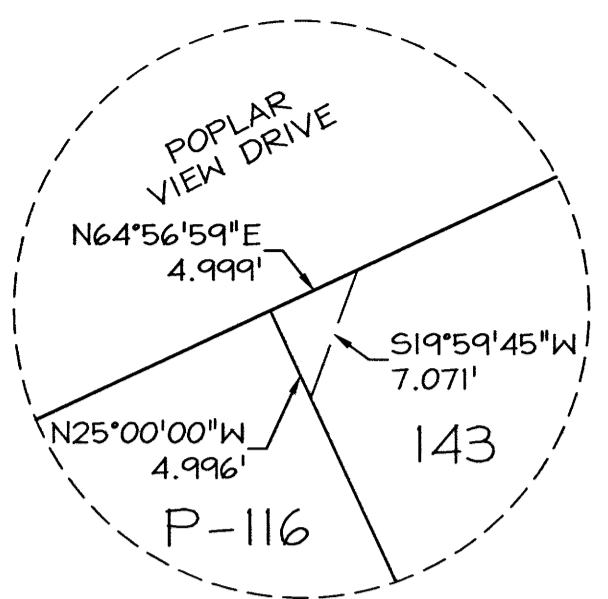

DETAIL "E"  
N.T.S.

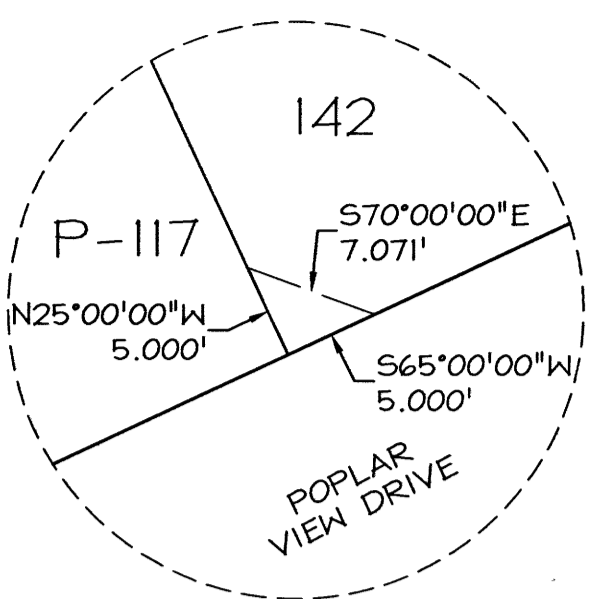

DETAIL "F"  
N.T.S.

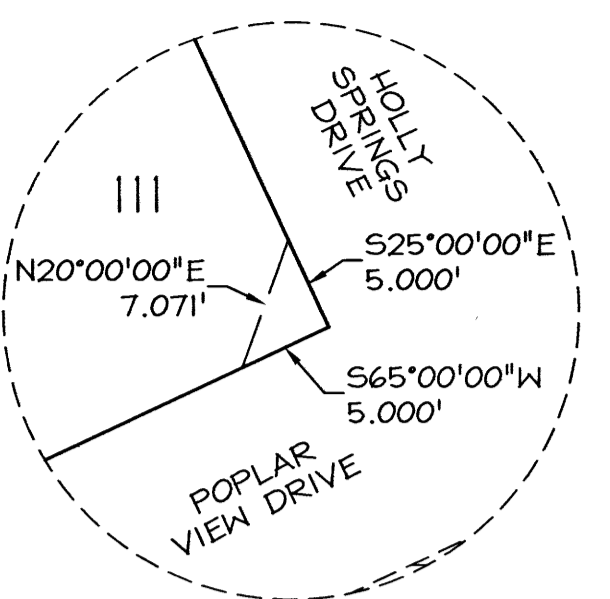

DETAIL "G"  
N.T.S.

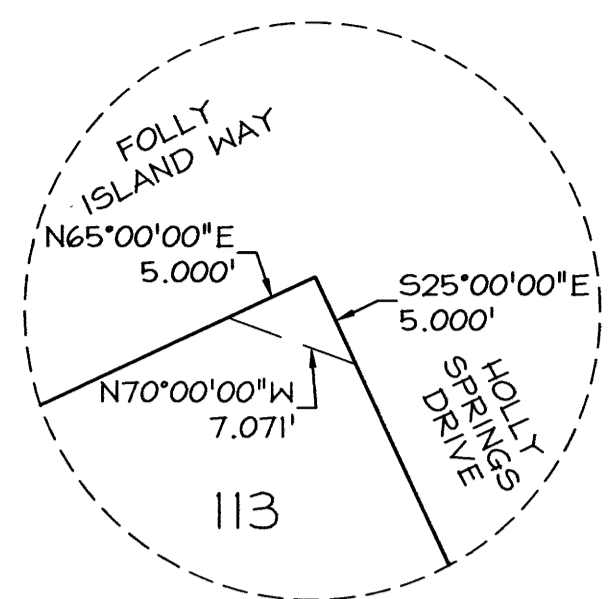

DETAIL "H"  
N.T.S.

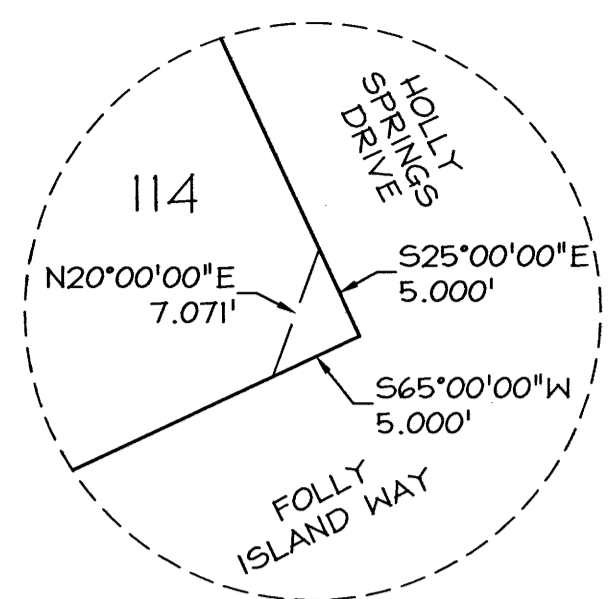

DETAIL "I"  
N.T.S.

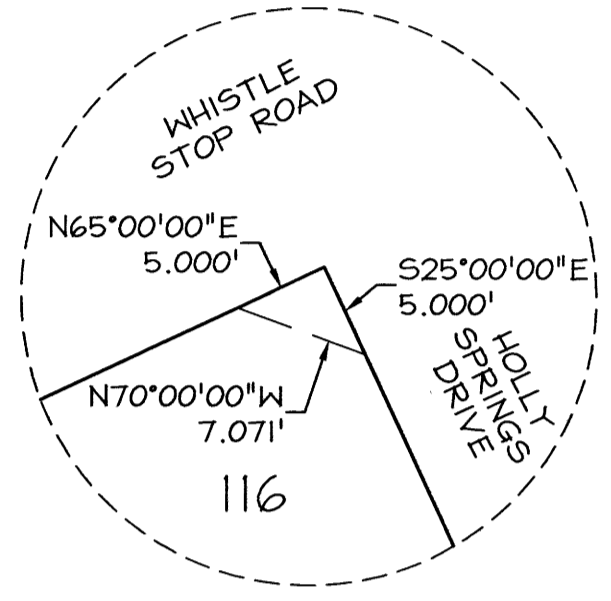

DETAIL "J"  
N.T.S.

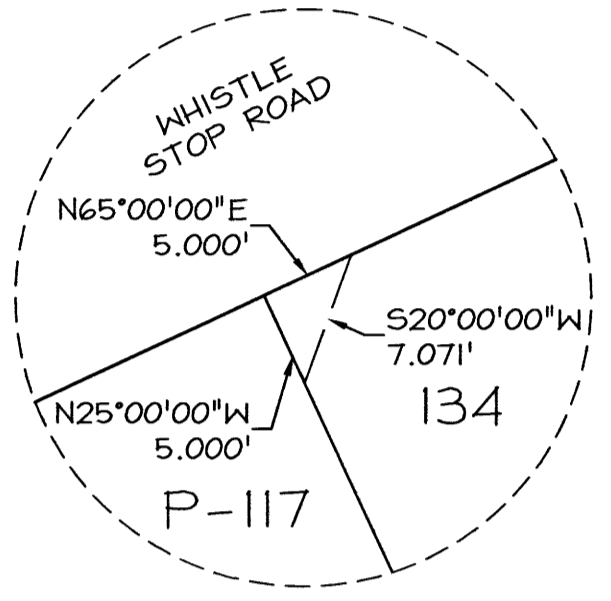

DETAIL "K"  
N.T.S.

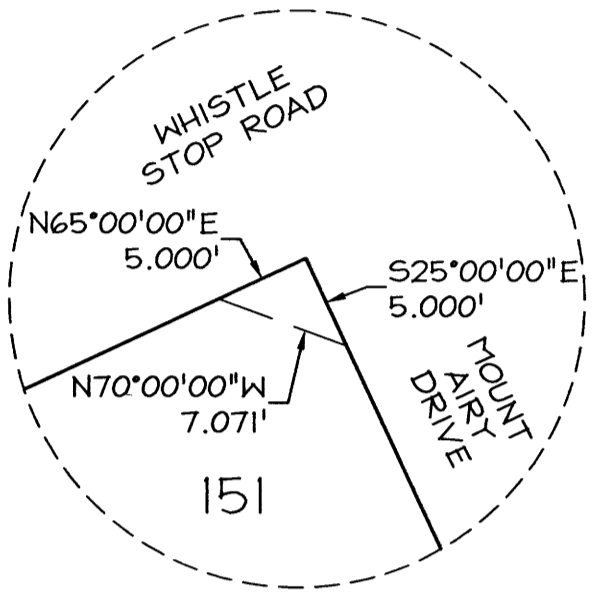

DETAIL "L"  
N.T.S.

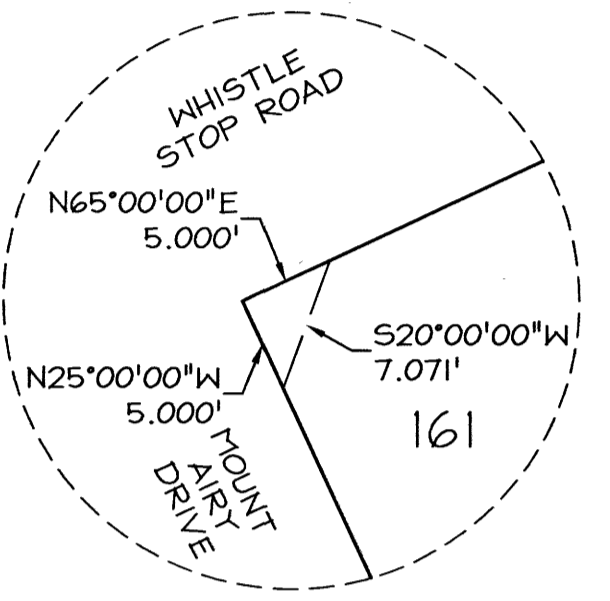

DETAIL "M"  
N.T.S.

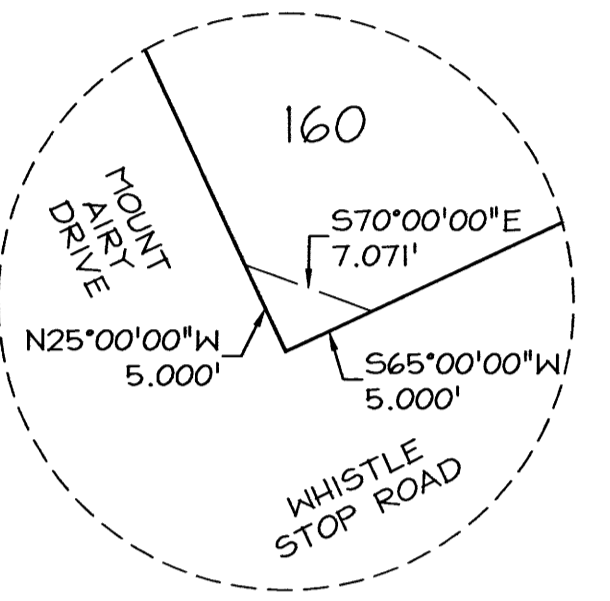

DETAIL "N"  
N.T.S.

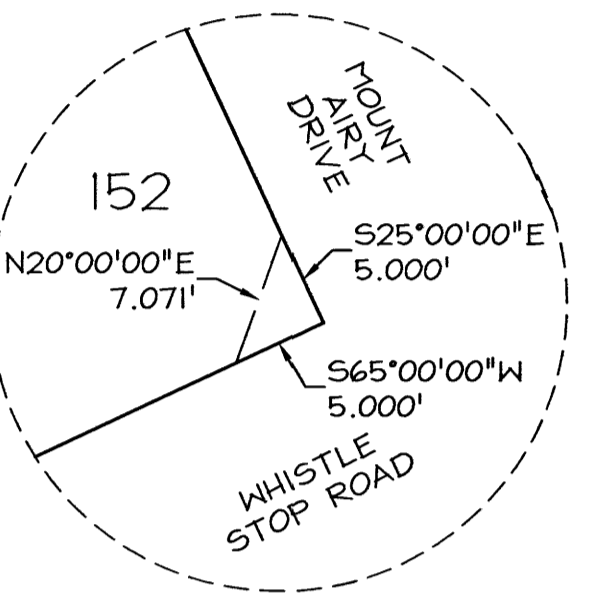

DETAIL "O"  
N.T.S.

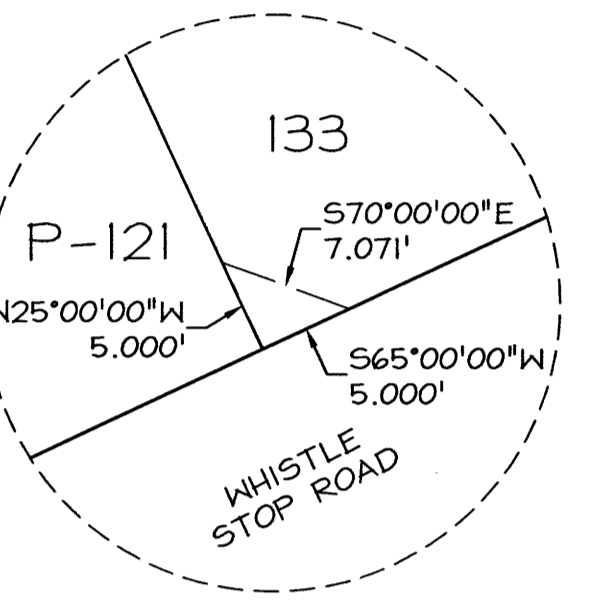

DETAIL "P"  
N.T.S.

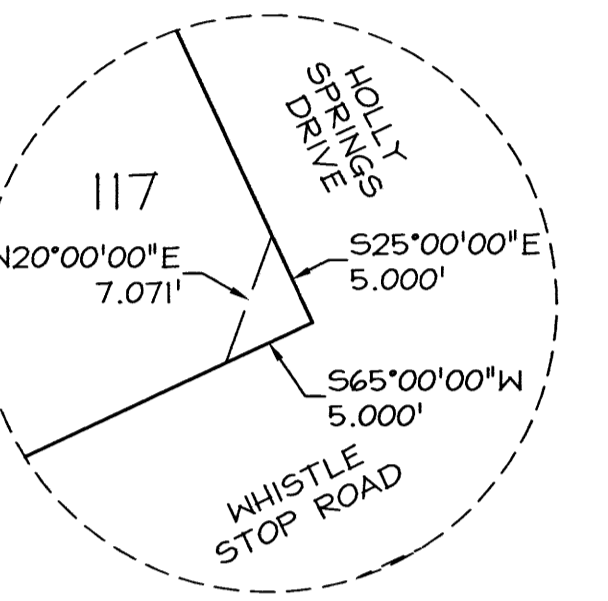

DETAIL "Q"  
N.T.S.

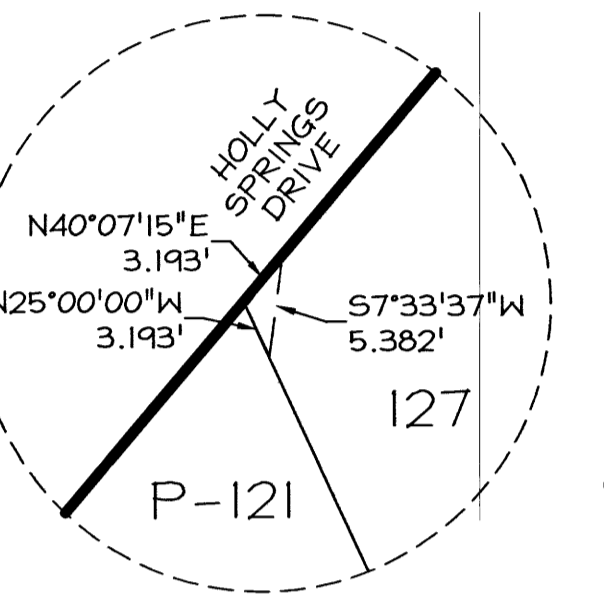

DETAIL "R"  
N.T.S.

**ACCESS EASEMENTS - LANES**  
 DETAILS "S" THROUGH "V" - ACCESS EASEMENTS FOR LANES TO  
 BE MAINTAINED BY SOUTH JORDAN CITY

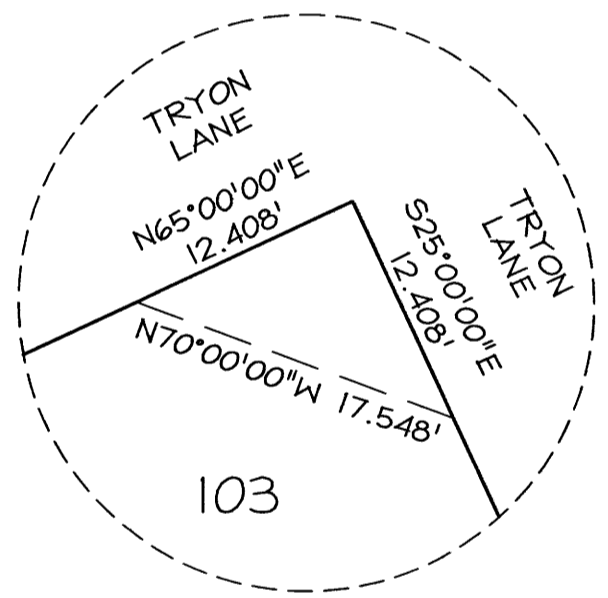

DETAIL "S"  
N.T.S.

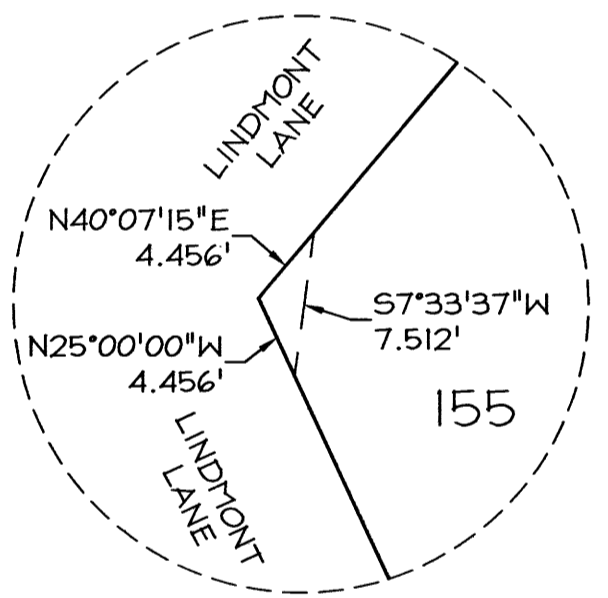

DETAIL "T"  
N.T.S.

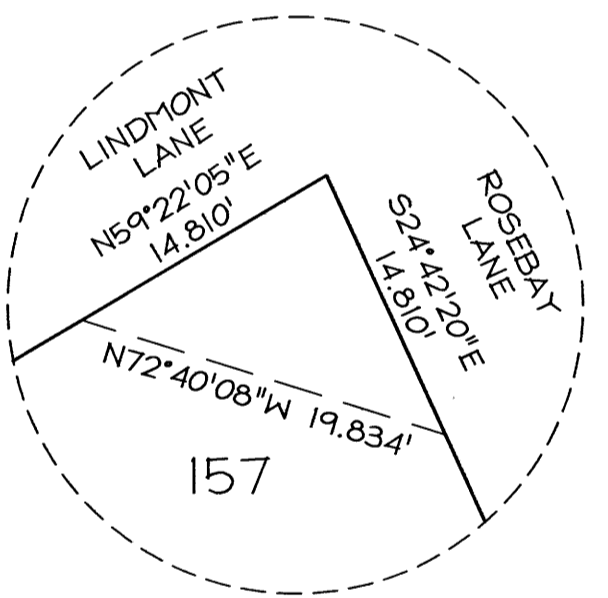

DETAIL "U"  
N.T.S.

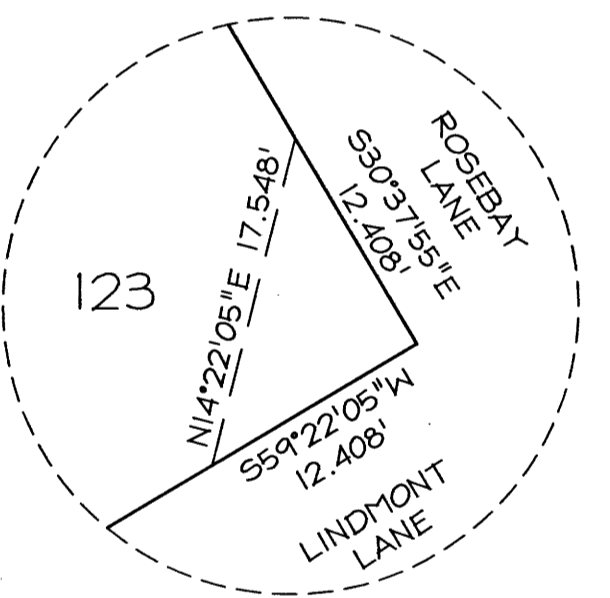

DETAIL "V"  
N.T.S.

Line #	Length	Direction
L1	28.000	N25°00'00"W
L2	28.000	S65°00'00"W
L3	61.602	S65°00'00"W
L4	49.756	S59°22'02"W
L5	12.810	N59°22'02"E
L6	16.519	N65°00'00"E
L7	61.101	N34°43'32"W
L8	27.150	S25°00'00"E
L9	45.236	S40°07'15"W
L10	44.593	S30°37'55"E
L11	58.915	S59°22'05"W
L12	20.000	N65°00'00"E
L13	20.000	N25°00'00"W
L14	20.000	N65°00'00"E
L15	10.000	N25°00'00"W
L16	20.000	N65°00'00"E
L17	10.000	N25°00'00"W
L18	16.313	N65°00'00"E
L19	14.314	S62°38'34"W
L20	20.000	S27°18'40"E

Line #	Length	Direction
L21	20.000	N65°00'00"E
L22	20.000	S65°00'00"W
L23	20.000	N65°00'00"E
L24	20.000	S65°00'00"W

Curve #	Length	Radius	Delta	Chord Bearing	Chord Length
C1	86.453	200.000	024°46'01"	S77°23'00"W	85.781
C2	19.662	200.000	005°37'58"	N62°11'01"E	19.655
C3	50.922	300.000	009°43'32"	N29°51'46"W	50.861
C4	44.326	39.000	065°07'15"	S07°33'37"W	41.979
C5	38.632	115.000	019°14'51"	S49°44'40"W	38.451
C6	22.415	228.000	005°37'58"	S62°11'01"W	22.406
C7	16.910	172.000	005°37'58"	N62°11'01"E	16.903
C8	12.502	11.000	065°07'15"	S07°33'37"W	11.840
C9	29.226	87.000	019°14'51"	S49°44'40"W	29.089
C10	17.700	67.000	015°08'12"	N17°25'54"W	17.649
C11	19.108	67.000	016°20'25"	N01°41'35"W	19.043
C12	39.342	67.000	033°38'37"	N23°17'56"E	38.779
C13	48.049	143.000	019°15'07"	N49°44'48"E	47.824
C14	33.593	200.000	009°37'25"	S44°55'57"W	33.554
C15	33.593	200.000	009°37'25"	S54°33'23"W	33.554
C16	93.153	215.500	024°46'01"	N77°23'00"E	92.429
C17	46.170	272.000	009°43'32"	N29°51'46"W	46.114
C18	55.675	328.000	009°43'32"	S29°51'46"E	55.608
C19	39.270	25.000	090°00'00"	S70°00'00"E	35.355
C20	39.270	25.000	090°00'00"	S20°00'00"W	35.355

**This map is provided solely for the purpose of assisting in locating the property and Cottonwood Title Insurance Agency, Inc. assumes no liability for variation, if any, with any actual survey.**

DAYBREAK VILLAGE 7 PLAT 1 SUBDIVISION  
 AMENDING LOT 100 OF THE DAYBREAK VILLAGE 7 SUBDIVISION AMENDED  
 AMENDING LOT 100 OF THE KENNECOTT DAYBREAK VILLAGE 7 SUBDIVISION  
 AMENDING LOTS V7 AND T6 OF THE KENNECOTT MASTER SUBDIVISION #1  
 AMENDED

Located in the Southwest quarter of Section 23,  
 T3S, R2W, Salt Lake Base and Meridian

RECORDED 8/2654610

STATE OF UTAH, COUNTY OF SALT LAKE, RECORDED AND FILED AT THE  
 REQUEST OF: First American Title

DATE: 11-8-2017 TIME: 9:35AM BOOK: 2017P PAGE: 308

FEE \$ 254.00

SALT LAKE COUNTY RECORDER

**PERIGEE CONSULTING**  
 CIVIL • STRUCTURAL • SURVEY

9089 SOUTH 1300 WEST, SUITE 160 WEST JORDAN, UT 84088  
 801.628.6004 TEL 801.590.6611 FAX WWW.PERIGEECONSULTING.COM

PLAT NUMBER	DAYBREAK PARK LOT AREA	DAYBREAK OPEN SPACE LOT AREA	COLLECTOR STREET PARK STRIP AREA	NON-COLLECTOR STREET PARK STRIP AREA	PARK AREA DEDICATED TO CITY	OPEN SPACE AREA DEDICATED TO CITY	TOTAL	NUMBER OF LANES	LINEAR FOOTAGE
△ PLAT 1	2.5723	22.23	2.28	5.23	26.0377	0	58.35	SEE AMENDED PLAT 1	
△ PLAT 1 AMENDED	12.61	22.17	2.28	5.23	26.0377	0	68.33	13	4,887.83
LOT M-104 AMENDED	0	0	0	0	0	0	0	0	0
△ PLAT 2	8.6753	1.0496	1.32	4.74	0	0	15.7849	SEE AMENDED PLAT 2	
PLAT 2 AMENDED	8.6093	1.0496	1.32	4.74	0	0	15.7189	21	6340.29
TOWNEHOME I SUB.	0	0	0	0	0	0	0	0	0
PLAT 3	2.6437	11.6106	0.32	5.89	0	0	20.4643	9	2,105.88
△ PLAT 4	0.7252	0.3496	0.24	1.97	0	0	3.2848	SEE AMENDED PLAT 4	
PLAT 4 AMENDED	0.7593	0.3363	0.24	1.97	0	0	3.3056	9	4589.98
CARRIAGE CONDOS	0	0	0	0	0	0	0	0	0
△ PLAT 5	2.9994	2.7368	1.18	5.39	0	0	12.3062	SEE AMENDED PLAT 5	
PLAT 5 AMENDED	5.7505	0	1.18	5.39	0	0	12.3205	36	10,719.18
PLAT 6	3.371	31.8148	0	3.89	0	0	39.0758	13	3532.29
△ PLAT 7	16.3272	7.6526	6.27	5.11	0	0	35.3598	SEE AMENDED PLAT 7C	
PLAT 3A	1.736	0	0.1	0.39	0	0	2.226	5	1,690.56
PLATS 3B-1 THRU 3B-10	0	0	0	0	0	0	0	0	0
CORPORATE CENTER #1	0	0	0.07	0.1	0	0	0.17	0	0
PLAT 8	* 13.8622	* 0.0431	0.38	3.77	0	0	* 18.0553	13	4,227.78
△ PLAT 7A AMENDED	16.3272	7.6526	6.27	5.11	0	0	35.3598	SEE AMENDED PLAT 7C	
△ EASTLAKE VILLAGE CONDOS	0	0	0	0	0	0	0	0	0
△ PLAT 9	17.8005	0	5.04	5.92	0	0	28.7605	SEE AMENDED PLAT 9A	
△ PLAT 7B AMENDED	14.7624	7.6526	7.83	5.11	0	0	35.355	SEE AMENDED PLAT 7C	
VILLAGE CENTER 1A	0	0	0	0	0	0	0	0	0
AMENDED EASTLAKE VILLAGE CONDOS	0	0	0	0	0	0	0	0	0
PLAT 9A AMENDED	17.8005	0	5.04	5.92	0	0	28.7605	38	11,087.08
△ AMENDED PLAT 1A	12.61	22.17	2.28	5.23	26.0377	0	68.3277	SEE AMENDED PLAT 1	
DAYBREAK VIEW PARKWAY SUBDIVISION FROM PLAT A1 TO THE EAST FRONTAGE ROAD	0	0	1.36	0	0	0	* 1.36	0	0
APARTMENT VENTURE #1	0	0	1.3	1.14	0	0	* 2.44	0	0
PLAT 3C	0	0	0.84	0	0	0	0.84	0	0
DAYBREAK VIEW PARKWAY SUBDIVISION FROM EAST FRONTAGE ROAD TO 11800 SOUTH	0	0	1.11	0.04	0	0	1.15	0	0
△ COMMERCE PARK PLAT 1	0	0	0.19	0.22	0	0	0.41	0	0
COMMERCE PARK PLAT 2	0	0	0.47	0	0	0	* 0.47	0	0
PLAT 8A-1	0	0	0	0	0	0	0	2	740
PLAT 8A-2	0	0	0	0	0	0	0	0	0
VILLAGE 4A PLAT 1	2.149	0	1.49	0	0	0	3.639	7	1,028.00
△ VILLAGE 4A PLAT 2	0.8623	0	0.61	0	0	0	1.4723	SEE AMENDED VILLAGE 4A PLAT 2	
PLAT 8A-3	0	0	0	0	0	0	0	0	0
PLAT 8A-4	0	0	0	0	0	0	0	0	0
PLATS 8A-5 THRU 8A-9	0	0	0	0	0	0	0	0	0
PLAT 7C AMENDED	14.7624	7.3647	7.83	5.11	0	0	35.0671	35	10,037.21
AMENDED VILLAGE 4A PLAT 2	0.8623	0	0.61	0	0	0	1.4723	3	709.76
EASTLAKE ELEMENTARY SCHOOL	0	0	0	0	0	0	0	0	0
COUPLET LINER PRODUCT #1	0	0	0	0	0	0	0	0	0
PLAT 3D	0.0138	0	0.12	0	0	0	0.1338	2	449.14
AMENDED PLAT 3B-10	0	0	0	0	0	0	0	1	33.72
VCI DAYCARE	0	0	0.38	0.04	0	0	0.42	0	0
VCI CONDO SUBDIVISION	0	0	0	0	0	0	0	0	0
VILLAGE 4A PLAT 3	2.9531	0	1.56	0.37	0	0	4.8831	3	1,283.96
BINGHAM CREEK PLAT	142.713	0	0	0	0	0	142.713	0	0
11400/MVC SE COMMERCIAL #1	0	0	0	0	0	0	0	0	0
QUESTAR/JVWCD PLAT	0	0	0	0	0	0	0	0	0
VILLAGE 4A MULTI FAMILY #1	1.05	0	0	0	0	0	1.05	0	0
△ UNIVERSITY MEDICAL #1	0	0	0.41	0	0	0	0.41	SEE AMENDED UNIV MEDICAL #1	
△ PLAT 10A	0.766	0	0.64	0	0	0	1.406	SEE AMENDED PLAT 10A	
△ VCI MULTI FAMILY #1	0.0903	0	0	0	0	0	0.0903	SEE AMENDED VCI MULTI FAMILY #1	
AMENDED PLAT 10A	0.766	0	0.64	0	0	0	1.406	2	1,291.32
△ GARDEN PARK CONDOMINIUMS, PHASE 1	0	0	0	0	0	0	0	0	0
△ GARDEN PARK CONDOMINIUMS, PHASE 3	0	0	0	0	0	0	0	0	0
△ PLAT 9B	0	0	0	0	0	0	0	0	0
△ PLAT 9C	-0.2014	0	0	0	0	0	-0.2014	0	0
PLAT 3E	0.0251	0	0.36	0	0	0	0.3851	1	389
AMENDED UNIVERSITY MEDICAL #1	0	0	0.26	0.22	0	0	0.48	0	0
SOUTH JORDAN PARKWAY ROW PLAT FROM SPLIT ROCK DRIVE TO 5360 WEST	0	0	1.21	0	0	0	1.21	0	0
PLAT 8C	0.0998	0	0	0	0	0	0.0998	0	0
AMENDED VCI MULTI FAMILY #1	0.0903	0	0	0	0	0	0.0903	3	412.58
VCI MULTI FAMILY #2A	0.11	0	0	0	0	0	0.111	1	502.5
PLAT 9D	0	0	0	0	0	0	0	2	484
AMENDED PLAT 3E	0	0	0	0	0	0	0	0	0
PLAT 7D	0	0	0	0	0	0	0	0	0
VCI MULTI FAMILY #2B	0.3087	0	0	0	0	0	0.3087	1	194.33
VILLAGE 4A PLAT 4	0.8077	0	0.26	0.23	0	0	1.2977	2	718.52
VILLAGE 4A PLAT 5	1.5901	0	0.68	0.00	0	0	2.2701	4	1125.22
PLAT 10B	0	0	0.2	0.09	0	0	0.29	0	0
PLAT 7E	0	0	0	0	0	0	0	0	0
PLAT 9F	0	0	0	0	0	0	0	0	0
PLAT 7F	0	0	0	0	0	0	0	0	0
VCI MULTI FAMILY #3	0.1297	0	0	0	0	0	0.1297	0	0
VILLAGE 4A MULTI FAMILY #2	0	0	0	0	0	0	0	0	0
△ PLAT 9G	-0.2921	0	0	0	0	0	-0.2921	6	1,303.42
PLAT 10C	1.0818	0	0.14	0.65	0	0	1.8718	4	1,097.20
PLAT 8D	0	0	0	0	0	0	0	0	0
PLAT 8B	0	0	0	0	0	0	0	0	0
PLAT 9H	0	0	0	0	0	0	0	0	0
VILLAGE 4 WEST PLAT 1	0.2552	0	2.02	0.48	0	0	2.7552	2.00	1088
VCI MULTI FAMILY #4	0	0	0	0	0	0	0	0	0
VILLAGE 4 EAST PLAT 1	1.4911	0	0	0.86	0	0	2.3511	6	1524.61
VCI MULTI FAMILY #4A	0.3296	0	0	0	0	0	0.3296	0	0
PLAT 10D	0.3384	0	0.18	0.35	0	0	0.8684	6	924.04
VCI MULTI FAMILY #5	0.2651	0	0	0	0	0	0.2651	0	0
VILLAGE 4A PLAT 6	1.002	0	0.99	0.31	0	0	2.302	10	1,837.74
PLAT 10E	0.9735	0	1.31	0.51	0	0	2.7935	8	2,892.33
PLAT 9I	0	0	0	0	0	0	0	0	0
OQUIRRH LAKE PLAT	0	105.945	0	0	0	0	105.945	0	0
VILLAGE 4 WEST PLAT 2	0.293	0	0	0.27	0	0	0.563	2	891.76

PLAT NUMBER	DAYBREAK PARK LOT AREA	DAYBREAK OPEN SPACE LOT AREA	COLLECTOR STREET PARK STRIP AREA	NON-COLLECTOR STREET PARK STRIP AREA	PARK AREA DEDICATED TO CITY	OPEN SPACE AREA DEDICATED TO CITY	TOTAL	NUMBER OF LANES	LINEAR FOOTAGE
VILLAGE 5 PLAT 1	0	0	0.58	0	0	0	0.58	0	0
△ PLAT 10F	6.7848	0	0	0	0	0	6.7848	0	0
VCI MULTI FAMILY #6	0.091	0	0	0	0	0	0.091	1	508.05
VILLAGE 5 PLAT 2	0.3984	0	0.13	0.72	0	0	1.2484	7	2,583.35
VILLAGE 5 PLAT 3	1.2195	0	0.22	1.11	0	0	2.5495	16	3,781.25
PLAT 10G	0	0	0.33	0.29	0	0	0.62	4	1,208.13
VILLAGE 4 EAST CONDOMINIUM NO. 1 AMENDED	0	0	0	0	0	0	0	0	0
VILLAGE 4 EAST CONDOMINIUM NO. 2 AMENDED	0	0	0	0	0	0	0	0	0
VILLAGE 4 EAST PLAT 2	0.1964	0	0	0.66	0	0	0.8564	6	1,524.61
VILLAGE 4 EAST PLAT 3	0.4098	0	0	0.21	0	0	0.6198	6	1,524.61
VILLAGE 4A PLAT 7	0	0	0.46	0.2	0	0	0.66	1	150
COMMERCE PARK PLAT 3	0	0	0	0	0	0	0	0	0
VILLAGE 5 PLAT 4	3.5868	0	0.1	0.96	0	0	4.6468	19	3532.59
VILLAGE 4A PLAT 8	0.3688	0	0.52	0.02	0	0	0.9088	6	1687.31
△ VILLAGE 4 WEST PLAT 1 AMENDED	0.1275	0	0	0	0	0	0.1275	0	0
VILLAGE 5 MULTI FAMILY #1	0.0903	0	0	0.02	0	0	0.1103	4	1161.21
VCI MULTI FAMILY #7	0.1485	0	0	0.04	0	0	0.1885	0	0
SOUTH STATION MULTI FAMILY #1	0.4972	0	0	0	0	0	0.4972	0	0
VILLAGE 7A PLAT 1	0	0	0.12	0	0	0	0.12	0	0
S. JORDAN PKWY. ROW DED. PLAT FROM 5360 WEST TO MT. VIEW CORR.	0	0	2.6	0	0	0	2.6	0	0
PLAT 10H	1.6574	0	1.17	0.99	0	0	3.8174	10	2672.92
VILLAGE 5 PLAT 5	0.0644	0	0.91	0.44	0	0	1.4144	4	1125.38
PLAT 10I	2.067	0	0.36	1.15	0	0	3.577	10	3294.81
VILLAGE 10 NORTH PLAT 1	0	0	0.15	0.04	0	0	0.19	0	0
VILLAGE 5 PLAT 6	0.5937	0	0.11	0	0	0	0.7037	2	752.23
VILLAGE 5 PLAT 7	0	0	0	0.34	0	0	0.34	2	672
UNIVERSITY MEDICAL #2	0	0	0.06	0	0	0	0.06	0	0
VILLAGE 10 NORTH PLAT 2	0	0	0	0	0	0	0	0	0
VILLAGE 7	6.0122	0	2.09	0	0	0	8.1022	0	0
LAKE AVENUE FROM MOUNTAIN VIEW CORRIDOR TO 6000 WEST	15.1509	0	1.32	0	0	0	16.4709	0	0
VILLAGE 7 PLAT 1	1.1435	0	0	0.74	0	0	1.8835	7	2183.79
VILLAGE 8 PLAT 1	0	0	0	0	0	0	0	2	363.33
VILLAGE 8 PLAT 2	19.8151	0	0.57	1.16	0	0	21.5451	10	3142.73
VILLAGE 5 PLAT 8	0.041	0	0.961	0	0	0	1.002	13	3117.71
LAKE AVENUE EAST	9.055	0	2.101	0	0	0	11.156	0	0
VILLAGE 4 EAST CONDOMINIUMS NO. 4	0	0	0	0	0	0	0	0	0
COMMERCE PARK PLAT 4	0	0	0	0	0	0	0	0	0
△ SOUTH STATION MULTI FAMILY #1 AMENDED	0.031	0	0	0	0	0	0.031	0	0
VILLAGE 4 EAST MULTI FAMILY #1	0.428	0	0	0	0	0	0.428	3	735.03
VILLAGE 4 EAST CONDOMINIUMS NO. 5	0	0	0	0	0	0	0	0	0
VILLAGE 4 EAST CONDOMINIUMS NO. 6	0	0	0	0	0	0	0	0	0
VILLAGE 4 EAST CONDOMINIUMS NO. 7	0	0	0	0	0	0	0	0	0
SOUTH STATION PLAT 1	0	0	0.526	0	0	0	0.526	0	0
VILLAGE 5 PLAT 9	0.824	0	0.747	0	0	0	1.571	6	1787
VILLAGE 4A PLAT 9	0.417	0	0.19	0	0	0	0.607	3	768.43
OPERATIONS-INVESTMENTS PLAT 1	0	0	0	0	0	0	0	0	0
△ VILLAGE 5 MULTI FAMILY #2	0.188	0	0	0	0	0	0	3	1307.00
VILLAGE 8 PLAT 3	4.064	0	2.149	0	0	0	6.213	22	7255.25
VILLAGE 4 WEST PLAT 3	0.483	0	0.08	0	0	0	0.563	2	253.91
LAKE ISLAND PLAT 1	2.868								