

NOTES:

- 1. In conjunction with the recordation of this plat for Amended Kennecott Daybreak Plat 10A Subdivision ("Plat"), there shall also be recorded, with respect to the "tract" described herein, a document entitled "Supplement to Covenant for Community for Daybreak Submitting Additional Property", and, with respect to the residential lots and certain other lots within this Plat, a document entitled "Supplement to Community Charter for Daybreak Submitting Additional Property" (each, a "Supplement"). The Supplements subject the "tract" described herein to a document entitled "Covenant for Community for Daybreak" (the "Covenant"), and the residential lots and certain other lots within this Plat to a second document entitled "Community Charter for Daybreak" (the "Charter"). In addition, any non-residential lot(s) may also have recorded against them a "Supplement to Amended and Restated Declaration of Covenants, Conditions and Restrictions for Daybreak Village Submitting Additional Property", which subjects such non-residential lot(s) within this Plat to the "Amended and Restated Declaration of Covenants, Conditions and Restrictions for Daybreak Village" (the "Village Declaration"). This Plat is part of a master-planned community commonly known as "Daybreak".

EASEMENT NOTE:

Owner certifies that the easements, claims of easements, or encumbrances on the platting property which are shown by public records are shown on this plat based on the title report issued by Salt Lake County Title Agency, Order Number 021-8336111, Amendment No. 4, with an effective date of April 23, 2010.

HIGH GROUND WATER:

Many areas in South Jordan City have ground water problems due to high (fluctuating) water table. Approval of this plat does not constitute representation by the City that building at any specified elevation will solve groundwater problems, if any.

SEWER LATERAL NOTE:

All lots contained within this Plat are served by private sewer laterals. The owner(s) of a lot in this Plat or of any portion of an Alpha Parcel which is served by a sewer lateral which traverses a lot labeled "P" or "Q", a public right-of-way, or a PUDE easement is hereby granted an easement over and through such "P" and/or "Q" lots, public rights-of-way and/or PUDE easements for the purpose of allowing such owner(s) the right to operate, maintain and repair such sewer lateral. Promptly following any construction, repairs or maintenance requiring disturbance of the surface or subsurface of a burdened property, the benefited party shall cause the surface and subsurface of the burdened property to be restored to a condition substantially similar to the condition immediately prior to such disturbance.

NOTICE:

Potential purchasers of property described on this plat are advised by South Jordan City to familiarize themselves with all notes, lot information, easements and other pertinent information contained on this plat and also with any Covenants, Conditions and Restrictions ("CCRs") recorded against such property, including those described in note 1 of this plat. Such property may also be subject to the restrictions of the Kennecott Development Standards Matrix ("Matrix") attached to the Kennecott Master Subdivision #1 Plat recorded in Book 2002P commencing at Page 273, in the Salt Lake County Recorder's Office, as it may be amended from time to time. These documents may limit the use of the property and failure to comply with such documents may result in financial losses to the property owner. Purchasers and property owners are responsible to review and to be in compliance with this plat, the CCRs, the Matrix and other recorded documents related to this plat, as currently existing or as may from time to time be changed and/or amended.

EASEMENT APPROVAL table with columns for QUEST, PACIFICORP, QUESTAR GAS, COMCAST and rows for DATE, APPROVED AS TO FORM THIS, and SALT LAKE VALLEY HEALTH DEPARTMENT.

SALT LAKE VALLEY HEALTH DEPARTMENT approval section with date of June 19, 2010 and signature of Olivia Gray.

SOUTH VALLEY SEWER DISTRICT approval section with date of June 19, 2010 and signature of General Manager.

PLANNING DEPARTMENT approval section with date of June 2nd, 2010 and signature of City Planner.

SOUTH JORDAN CITY ENGINEER approval section with date of June 10, 2010 and signature of Brad Klavans.

OFFICE OF THE CITY ATTORNEY approval section with date of June 16, 2010 and signature of Attorney for South Jordan City.

SOUTH JORDAN CITY MAYOR approval section with date of June 18, 2010 and signature of Mayor.

CITY RECORDER approval section with date of June 18, 2010 and signature of City Recorder.

STATE OF UTAH, COUNTY OF SALT LAKE, RECORDED AND FILED AT THE REQUEST OF First American Title, dated 6/18/10, TIME: 2:22, BOOK: 2008, PAGE: 106, FEE \$ 19.91, and signature of Annie Johnson Deery.

AMENDED KENNECOTT DAYBREAK PLAT 10A SUBDIVISION AMENDING LOTS 112, 113, 117, 118, 119, 123, 124, 142, 149 AND 150 AND ADDING LOTS 160 THRU 165

Located in the Northeast Quarter of Section 13, T.35, R.21W, and the Northwest Quarter of Section 18, T.35, R.1W, S.L.B.#M.

Table with 2 columns: Description and Area. Includes items like 'Containing 65 Lots (6.531 acres)', 'Containing 5 P-Lots (Park) (0.766 acres)', 'Containing 2 Public Lanes (0.607 acres)', 'Street Right-of-Way (2.721 acres)', and 'Total (10.625 acres)'.

DEVELOPED BY: KENNECOTT LAND RESIDENTIAL DEVELOPMENT COMPANY, 4700 Daybreak Parkway, South Jordan, Utah 84095, Phone (801) 204-2000

OWNER'S DEDICATION

Know all men by these presents that I, the undersigned owner of the above described tract of land, hereafter known as AMENDED KENNECOTT DAYBREAK PLAT 10A SUBDIVISION AMENDING LOTS 112, 113, 117, 118, 119, 123, 124, 142, 149 AND 150 AND ADDING LOTS 160 THRU 165 do hereby dedicate for perpetual use of the public all parcels of land and easements as shown on this plat as intended for public use.

In witness whereof I have here unto set my hand this 21st day of May, A.D., 2010. MICHAEL W. JOHNSON, Vice President of Land Acquisition, RICHMOND AMERICAN HOMES OF UTAH, INC.

CORPORATE ACKNOWLEDGMENT: Notary Public WENDY FORTNER, Salt Lake County, Utah, on the 21st day of May, A.D., 2010.

OWNER'S DEDICATION

Know all men by these presents that I, the undersigned owner of the above described tract of land, hereafter known as AMENDED KENNECOTT DAYBREAK PLAT 10A SUBDIVISION AMENDING LOTS 112, 113, 117, 118, 119, 123, 124, 142, 149 AND 150 AND ADDING LOTS 160 THRU 165 do hereby dedicate for perpetual use of the public all parcels of land and easements as shown on this plat as intended for public use.

In witness whereof I have here unto set my hand this 21st day of May, A.D., 2010. Bryson Garbett, COTLAND DEVELOPMENT, INC.

CORPORATE ACKNOWLEDGMENT: Notary Public NATALIE K. ALBERICO, Salt Lake County, Utah, on the 21st day of May, A.D., 2010.

OWNER'S DEDICATION

Know all men by these presents that I, the undersigned owner of the above described tract of land, hereafter known as AMENDED KENNECOTT DAYBREAK PLAT 10A SUBDIVISION AMENDING LOTS 112, 113, 117, 118, 119, 123, 124, 142, 149 AND 150 AND ADDING LOTS 160 THRU 165 do hereby dedicate for perpetual use of the public all parcels of land and easements as shown on this plat as intended for public use.

In witness whereof I have here unto set my hand this 21st day of May, A.D., 2010. Ty K. McCutcheon, KENNECOTT LAND RESIDENTIAL DEVELOPMENT COMPANY, by Vice President Daybreak.

CORPORATE ACKNOWLEDGMENT: Notary Public NATALIE K. ALBERICO, Salt Lake County, Utah, on the 21st day of May, A.D., 2010.

SURVEYOR'S CERTIFICATE

I, Lyle G. Bissegger do hereby certify that I am a registered Professional Land Surveyor, and that I hold certificate No. 376982, as prescribed under the laws of the state of Utah. I further certify that by the authority of the owners, I have made a survey of the tract of land shown on this plat and described below, and have subdivided said tract of land into lots and streets, hereafter to be known as Amended Kennecott Daybreak Plat 10A Subdivision Amending Lots 112, 113, 117, 118, 119, 123, 124, 142, 149 and 150 and adding Lots 160 thru 165 and that same has been correctly surveyed and staked on the ground as shown on this plat.

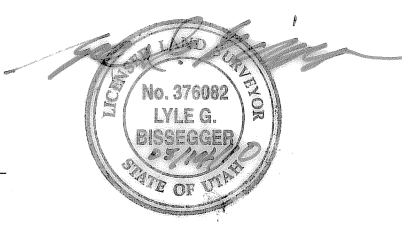

BOUNDARY LEGAL DESCRIPTION:

A PARCEL OF LAND LOCATED IN THE NORTHEAST QUARTER OF SECTION 13, TOWNSHIP 3 SOUTH, RANGE 2 WEST, AND THE NORTHWEST QUARTER OF SECTION 18, TOWNSHIP 3 SOUTH, RANGE 1 WEST, SALT LAKE BASE AND MERIDIAN AND BEING MORE PARTICULARLY DESCRIBED AS FOLLOWS: COMMENCING AT THE NORTHEAST CORNER OF SAID SECTION 13; THENCE S89°57'36"W ALONG THE NORTH LINE OF SAID NORTHEAST QUARTER, A DISTANCE OF 1053.197 FEET; THENCE LEAVING SAID LINE S00°02'24"E A DISTANCE OF 1453.778 FEET TO A POINT ON THE SOUTHERLY BOUNDARY OF THE KENNECOTT DAYBREAK PLAT 9 SUBDIVISION RECORDED IN BOOK 2007P AT PAGE 425 IN THE OFFICE OF THE SALT LAKE COUNTY RECORDER AND A 103.00 FOOT RADIUS CURVE TO THE RIGHT, THE CENTER OF WHICH BEARS S00°00'00"E; THENCE ALONG THE SOUTHERLY BOUNDARY OF SAID KENNECOTT DAYBREAK PLAT 9 THE FOLLOWING FOUR (4) COURSES: 1. NORTHEASTERLY ALONG SAID CURVE TO THE RIGHT HAVING A CENTRAL ANGLE OF 02°33'42" (CHORD BEARING AND DISTANCE OF N88°43'01"E - 52.81 FEET) FOR A DISTANCE OF 52.81 FEET; 2. THENCE N90°00'00"E, A DISTANCE OF 864.478 FEET TO A POINT ON A 14,000 FOOT RADIUS CURVE TO THE RIGHT, THE CENTER OF WHICH BEARS S00°00'00"E; 3. THENCE SOUTHEASTERLY ALONG SAID CURVE TO THE RIGHT HAVING A CENTRAL ANGLE OF 58°29'40" (CHORD BEARING AND DISTANCE OF S60°45'10"E - 13,680 FEET) FOR A DISTANCE OF 14,293 FEET TO A POINT ON A 14,000 FOOT RADIUS CURVE TO THE LEFT, THE CENTER OF WHICH BEARS N58°29'40"E; 4. THENCE SOUTHEASTERLY ALONG SAID CURVE TO THE LEFT HAVING A CENTRAL ANGLE OF 75°45'32" (CHORD BEARING AND DISTANCE OF S64°23'06"E - 173.15 FEET) FOR A DISTANCE OF 186.44 FEET TO A POINT ON A 14,000 FOOT RADIUS CURVE TO THE LEFT, THE CENTER OF WHICH BEARS S17°15'52"E; THENCE LEAVING SAID LINE SOUTHWESTERLY ALONG SAID CURVE TO THE LEFT HAVING A CENTRAL ANGLE OF 72°44'08" (CHORD BEARING AND DISTANCE OF S36°22'04"W - 16.60 FEET) FOR A DISTANCE OF 17.77 FEET; THENCE S00°00'00"E, A DISTANCE OF 747.66 FEET; THENCE S90°00'00"W, A DISTANCE OF 62.00 FEET; THENCE N00°00'00"W, A DISTANCE OF 271.68 FEET; THENCE S90°00'00"W, A DISTANCE OF 326.48 FEET TO A POINT ON A 172.00 FOOT RADIUS CURVE TO THE RIGHT, THE CENTER OF WHICH BEARS N00°00'00"E; THENCE NORTHWESTERLY ALONG SAID CURVE TO THE RIGHT HAVING A CENTRAL ANGLE OF 76°33'46" (CHORD BEARING AND DISTANCE OF N51°43'07"W - 213.12 FEET) FOR A DISTANCE OF 229.84 FEET; THENCE N13°26'14"E, A DISTANCE OF 77.52 FEET TO A POINT ON A 491.00 FOOT RADIUS CURVE TO THE RIGHT, THE CENTER OF WHICH BEARS N10°08'18"W; THENCE NORTHWESTERLY ALONG SAID CURVE TO THE RIGHT HAVING A CENTRAL ANGLE OF 91°10'08" (CHORD BEARING AND DISTANCE OF N55°32'44"W - 615.80 FEET) FOR A DISTANCE OF 685.93 FEET TO THE POINT OF BEGINNING. CONTAINING 462,823 SQUARE FEET OR 10.625 ACRES. BASIS OF BEARINGS: NORTH LINE OF THE NORTHEAST QUARTER OF SECTION 13, TOWNSHIP 3 SOUTH, RANGE 2 WEST, OF THE SALT LAKE BASE AND MERIDIAN. ASSUMED TO BEAR N 89°57'36"W

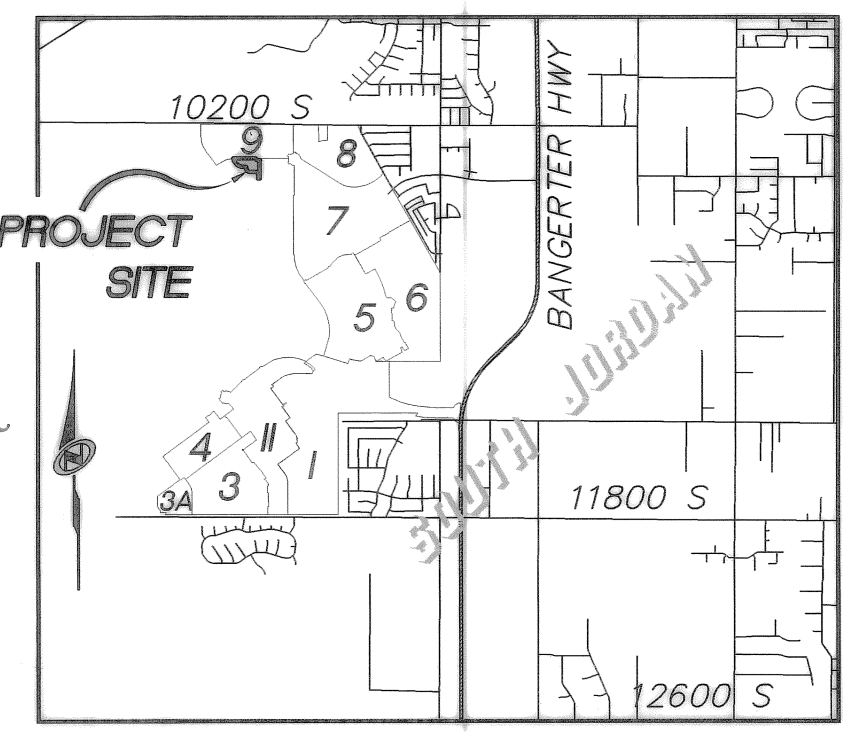

OWNER'S DEDICATION

Know all men by these presents that I, the undersigned owner of the above described tract of land, hereafter known as AMENDED KENNECOTT DAYBREAK PLAT 10A SUBDIVISION AMENDING LOTS 112, 113, 117, 118, 119, 123, 124, 142, 149 AND 150 AND ADDING LOTS 160 THRU 165 do hereby dedicate for perpetual use of the public all parcels of land and easements as shown on this plat as intended for public use.

In witness whereof I have here unto set my hand this 18th day of May, A.D., 2010. Ty K. McCutcheon, Vice President Daybreak.

CORPORATE ACKNOWLEDGMENT: Notary Public NATALIE K. ALBERICO, Salt Lake County, Utah, on the 18th day of May, A.D., 2010.

The Owner's Dedication was acknowledged before me this 18th day of May, 2010, by Ty K. McCutcheon as Vice President Daybreak for Kennecott Land Residential Development Company, a Delaware corporation.

Notary Public NATALIE K. ALBERICO, Salt Lake County, Utah, on the 18th day of May, A.D., 2010.

STATE OF UTAH, COUNTY OF SALT LAKE, RECORDED AND FILED AT THE REQUEST OF First American Title, dated 6/18/10, TIME: 2:22, BOOK: 2008, PAGE: 106, FEE \$ 19.91, and signature of Annie Johnson Deery.

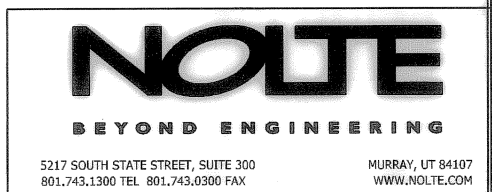

RECORDED # 10A72762, SHEET 1 OF 4, 26-13-276-008, 013, 017, 26-13-276-013, 014, 016, 017, 011, 012

DATE: 5/16/10, TIME: 11:23:56, AMOUNT: UNAPPORTIONED-10A, EP-SUB12, SCALE: 3/32"=1'-0", SOURCE: NOLTE, VENDOR: NOLTE ASSOCIATES, INC., PROJECT: AMENDED KENNECOTT DAYBREAK PLAT 10A, SHEET: 2 OF 4

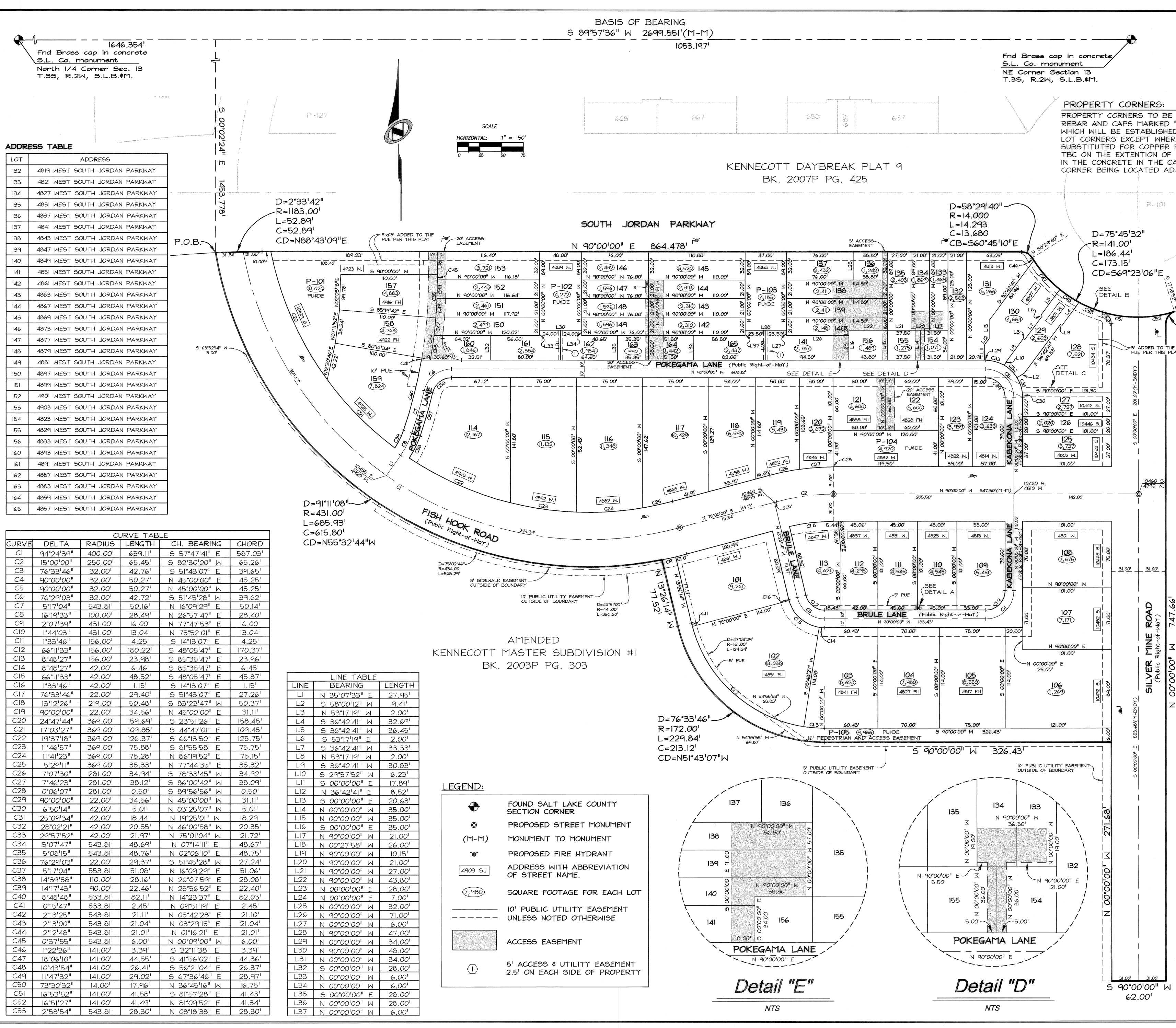

ADDRESS TABLE

LOT	ADDRESS
132	4819 WEST SOUTH JORDAN PARKWAY
133	4821 WEST SOUTH JORDAN PARKWAY
134	4827 WEST SOUTH JORDAN PARKWAY
135	4831 WEST SOUTH JORDAN PARKWAY
136	4837 WEST SOUTH JORDAN PARKWAY
137	4841 WEST SOUTH JORDAN PARKWAY
138	4843 WEST SOUTH JORDAN PARKWAY
139	4847 WEST SOUTH JORDAN PARKWAY
140	4849 WEST SOUTH JORDAN PARKWAY
141	4851 WEST SOUTH JORDAN PARKWAY
142	4861 WEST SOUTH JORDAN PARKWAY
143	4863 WEST SOUTH JORDAN PARKWAY
144	4867 WEST SOUTH JORDAN PARKWAY
145	4869 WEST SOUTH JORDAN PARKWAY
146	4873 WEST SOUTH JORDAN PARKWAY
147	4877 WEST SOUTH JORDAN PARKWAY
148	4879 WEST SOUTH JORDAN PARKWAY
149	4881 WEST SOUTH JORDAN PARKWAY
150	4891 WEST SOUTH JORDAN PARKWAY
151	4899 WEST SOUTH JORDAN PARKWAY
152	4901 WEST SOUTH JORDAN PARKWAY
153	4903 WEST SOUTH JORDAN PARKWAY
154	4823 WEST SOUTH JORDAN PARKWAY
155	4829 WEST SOUTH JORDAN PARKWAY
156	4833 WEST SOUTH JORDAN PARKWAY
160	4893 WEST SOUTH JORDAN PARKWAY
161	4891 WEST SOUTH JORDAN PARKWAY
162	4887 WEST SOUTH JORDAN PARKWAY
163	4883 WEST SOUTH JORDAN PARKWAY
164	4859 WEST SOUTH JORDAN PARKWAY
165	4857 WEST SOUTH JORDAN PARKWAY

CURVE TABLE

CURVE	DELTA	RADIUS	LENGTH	CH. BEARING	CHORD
C1	94°21'39"	400.00'	659.11'	S 57°47'41" E	587.03'
C2	15°00'00"	250.00'	65.45'	S 82°30'00" W	65.26'
C3	76°33'46"	32.00'	42.76'	S 51°43'07" E	39.65'
C4	90°00'00"	32.00'	50.27'	N 45°00'00" E	45.25'
C5	90°00'00"	32.00'	50.27'	S 45°00'00" W	45.25'
C6	76°29'28"	32.00'	42.72'	S 51°45'28" E	39.62'
C7	5°17'04"	543.81'	50.16'	N 16°09'29" E	50.14'
C8	16°19'33"	100.00'	28.49'	N 26°57'47" E	28.40'
C9	2°07'39"	431.00'	16.00'	N 77°47'53" E	16.00'
C10	1°44'03"	431.00'	13.04'	N 75°52'01" E	13.04'
C11	1°33'46"	156.00'	4.25'	S 14°13'07" E	4.25'
C12	66°11'33"	156.00'	180.22'	S 48°05'47" E	170.37'
C13	8°48'27"	156.00'	23.98'	S 85°35'47" E	23.96'
C14	8°48'27"	42.00'	6.46'	S 85°35'47" E	6.45'
C15	66°11'33"	42.00'	48.52'	S 48°05'47" E	45.87'
C16	1°33'46"	42.00'	1.15'	S 14°13'07" E	1.15'
C17	76°33'46"	22.00'	29.40'	S 51°43'07" E	27.26'
C18	13°12'26"	214.00'	50.48'	S 83°23'47" W	50.37'
C19	90°00'00"	22.00'	34.56'	N 45°00'00" E	31.11'
C20	24°47'44"	369.00'	159.69'	S 23°51'26" E	158.45'
C21	17°03'27"	369.00'	109.85'	S 44°47'01" E	109.45'
C22	19°37'18"	369.00'	126.37'	S 66°13'50" E	125.75'
C23	11°46'57"	369.00'	75.88'	S 81°55'58" E	75.75'
C24	11°41'23"	369.00'	75.28'	N 86°14'52" E	75.15'
C25	5°22'11"	369.00'	35.33'	N 77°44'35" E	35.32'
C26	7°07'30"	281.00'	34.94'	S 78°33'51" E	34.92'
C27	7°46'23"	281.00'	38.12'	S 86°00'42" W	38.09'
C28	0°06'07"	281.00'	0.50'	S 89°56'56" E	0.50'
C29	90°00'00"	22.00'	34.56'	N 45°00'00" E	31.11'
C30	6°50'14"	42.00'	5.01'	N 03°25'07" W	5.01'
C31	25°09'34"	42.00'	18.44'	N 14°25'01" W	18.29'
C32	28°02'21"	42.00'	20.95'	N 46°00'58" E	20.95'
C33	28°19'57"	42.00'	21.97'	N 75°01'04" E	21.72'
C34	5°07'47"	543.81'	48.64'	N 07°14'11" E	48.67'
C35	5°08'15"	543.81'	48.76'	N 02°06'10" E	48.75'
C36	76°29'03"	22.00'	29.37'	S 51°45'28" W	27.24'
C37	5°17'04"	543.81'	51.08'	N 16°09'29" E	51.06'
C38	14°39'58"	110.00'	28.16'	N 26°07'54" E	28.08'
C39	14°17'43"	90.00'	22.46'	N 25°56'52" E	22.40'
C40	8°48'48"	533.81'	82.11'	N 14°23'37" E	82.03'
C41	1°15'47"	533.81'	2.45'	N 09°51'19" E	2.45'
C42	2°13'25"	543.81'	21.11'	N 05°42'28" E	21.10'
C43	2°13'00"	543.81'	21.04'	N 03°29'15" E	21.04'
C44	2°12'48"	543.81'	21.01'	N 01°16'21" E	21.01'
C45	0°37'55"	543.81'	6.00'	N 00°09'00" W	6.00'
C46	1°22'36"	141.00'	3.99'	S 32°11'38" E	3.99'
C47	18°05'10"	141.00'	44.55'	S 41°56'02" E	44.36'
C48	10°43'54"	141.00'	26.41'	S 56°21'04" E	26.37'
C49	11°47'32"	141.00'	29.02'	S 67°36'46" E	28.97'
C50	7°33'32"	14.00'	17.96'	N 36°45'16" W	16.75'
C51	16°53'52"	141.00'	41.58'	S 81°57'28" E	41.43'
C52	16°51'27"	141.00'	41.49'	N 81°09'52" E	41.34'
C53	2°58'54"	543.81'	28.30'	N 08°18'38" E	28.30'

LINE TABLE

LINE	BEARING	LENGTH
L1	N 35°07'33" E	27.95'
L2	S 58°00'12" W	9.41'
L3	N 53°17'19" N	2.00'
L4	S 36°42'41" W	32.69'
L5	S 36°42'41" W	36.45'
L6	S 53°17'19" E	2.00'
L7	S 36°42'41" W	33.33'
L8	N 53°17'19" N	2.00'
L9	S 36°42'41" W	30.83'
L10	S 29°57'59" W	6.23'
L11	S 00°00'00" E	17.89'
L12	N 36°42'41" E	8.52'
L13	S 00°00'00" W	20.63'
L14	N 00°00'00" W	35.00'
L15	N 00°00'00" W	35.00'
L16	S 00°00'00" E	35.00'
L17	N 90°00'00" E	21.00'
L18	N 00°22'58" E	26.00'
L19	N 90°00'00" W	10.15'
L20	N 90°00'00" W	21.00'
L21	N 90°00'00" W	27.00'
L22	N 90°00'00" W	43.80'
L23	N 00°00'00" E	28.00'
L24	N 00°00'00" E	7.00'
L25	N 00°00'00" W	32.00'
L26	N 90°00'00" W	71.00'
L27	N 00°00'00" W	6.00'
L28	N 90°00'00" W	47.00'
L29	N 00°00'00" W	34.00'
L30	N 90°00'00" W	48.00'
L31	N 00°00'00" W	34.00'
L32	S 00°00'00" E	28.00'
L33	N 00°00'00" W	6.00'
L34	N 00°00'00" W	6.00'
L35	S 00°00'00" E	28.00'
L36	N 00°00'00" W	28.00'
L37	N 00°00'00" W	6.00'

LEGEND:

- FOUND SALT LAKE COUNTY SECTION CORNER
- PROPOSED STREET MONUMENT
- MONUMENT TO MONUMENT
- PROPOSED FIRE HYDRANT
- ADDRESS WITH ABBREVIATION OF STREET NAME.
- SQUARE FOOTAGE FOR EACH LOT
- 10' PUBLIC UTILITY EASEMENT UNLESS NOTED OTHERWISE
- ACCESS EASEMENT
- 5' ACCESS & UTILITY EASEMENT 2.5' ON EACH SIDE OF PROPERTY

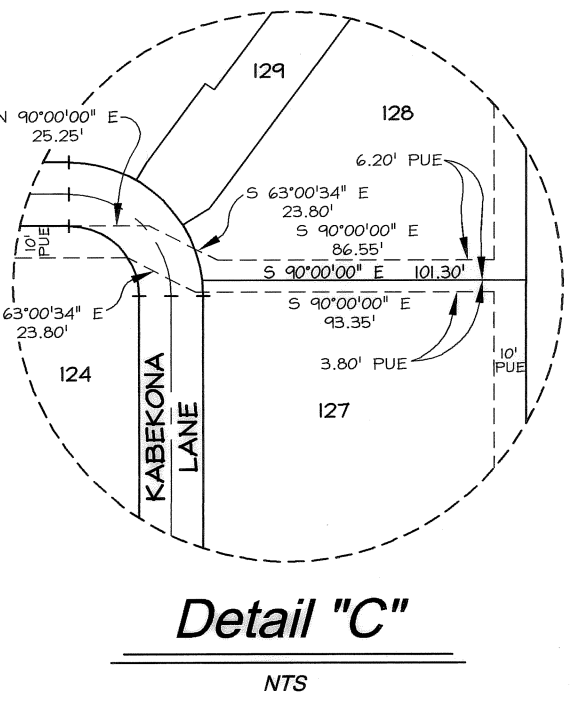
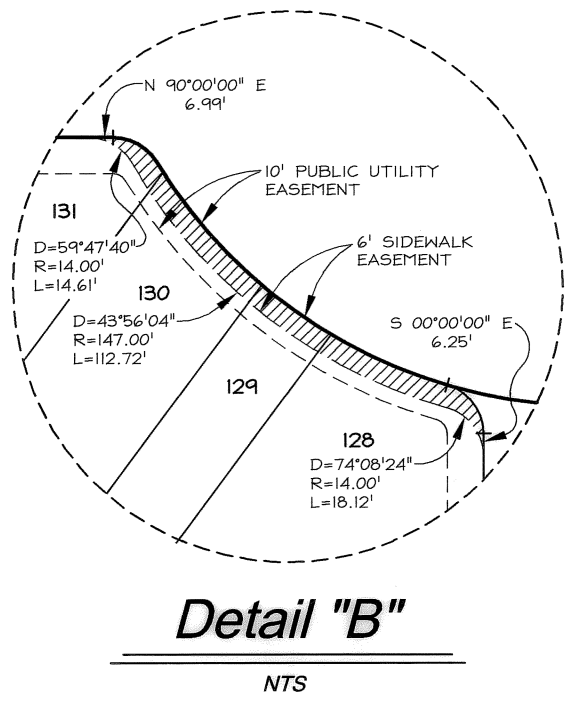
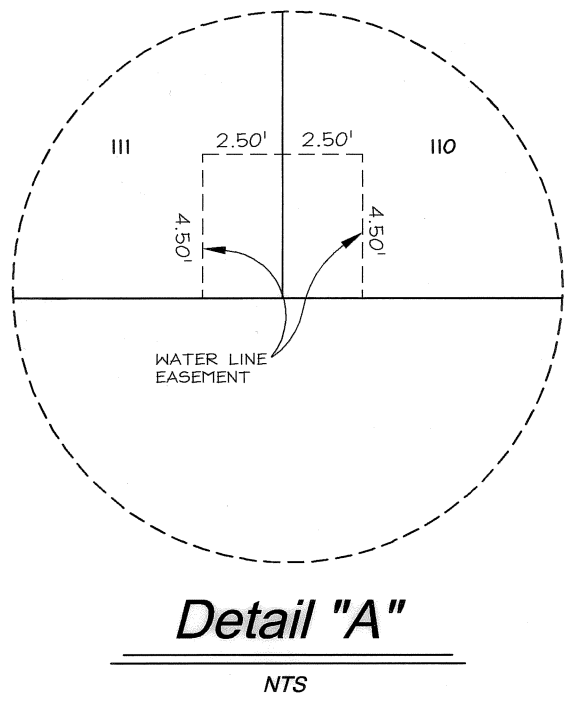
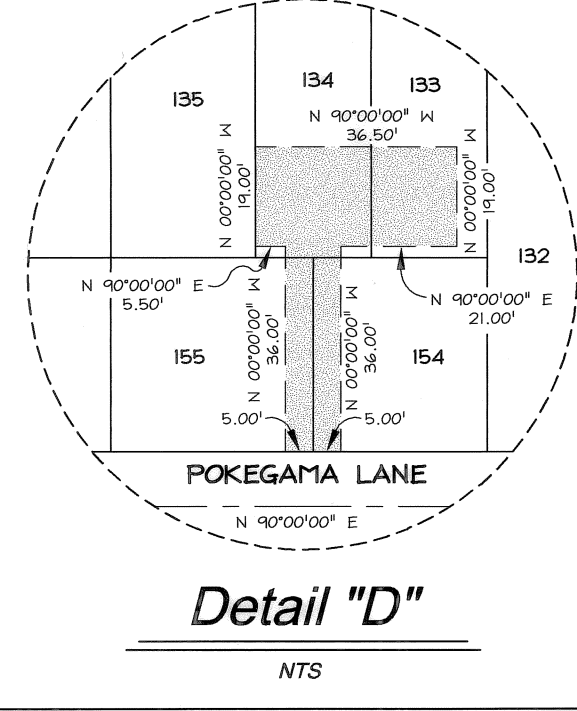
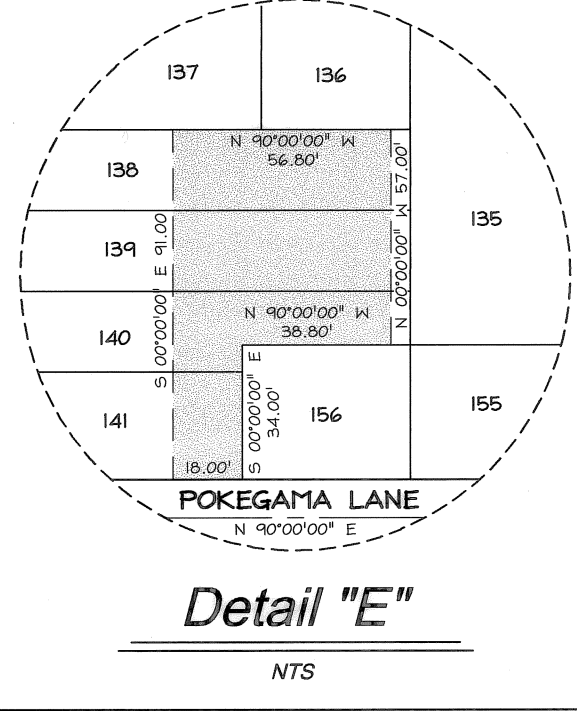

Sheet 2 of 4



AMENDED KENNECOTT DAYBREAK PLAT 10A SUBDIVISION
 AMENDING LOTS 112, 113, 117, 118, 119, 123, 124, 142, 149 AND 150
 AND ADDING LOTS 160 THRU 165

Located in the Northeast Quarter of Section 13, T.35, R.24,
 and the Northwest Quarter of Section 13, T.35, R.14, S.L.B.#11.

STATE OF UTAH, COUNTY OF SALT LAKE, RECORDED & FILED AT THE
 REQUEST OF: **FIRST AMERICAN TITLE**

DATE: 11/12/10 TIME: 2:22 PM BOOK: 2010P PAGE: 106

11/24/10
 SALT LAKE COUNTY RECORDER

DATE: 5/17/20 BY: J.B.S. DRAWN BY: J.B.S. CHECKED BY: J.B.S. APPROVED BY: J.B.S. SCALE: HORIZONTAL: 1" = 50'

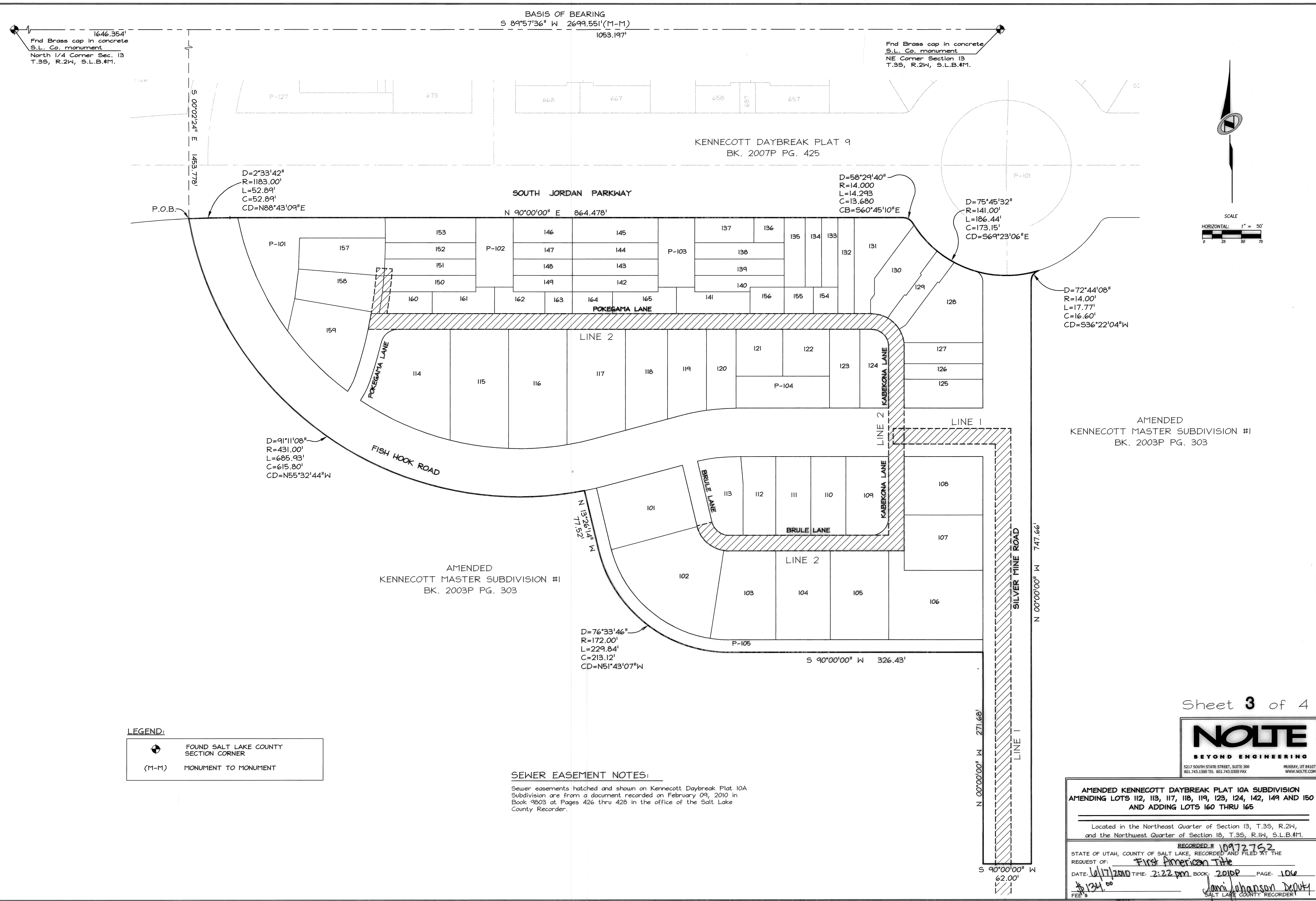

LEGEND:

FOUND SALT LAKE COUNTY SECTION CORNER

(M-M) MONUMENT TO MONUMENT

SEWER EASEMENT NOTES:

Sewer easements hatched and shown on Kennecott Daybreak Plat 10A Subdivision are from a document recorded on February 09, 2010 in Book 9803 at Pages 426 thru 428 in the office of the Salt Lake County Recorder.

Sheet 3 of 4

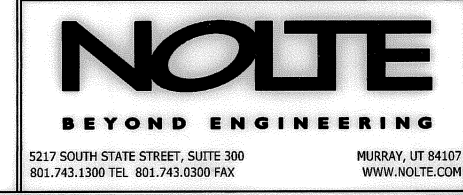

AMENDED KENNECOTT DAYBREAK PLAT 10A SUBDIVISION
AMENDING LOTS 112, 113, 117, 118, 119, 123, 124, 142, 149 AND 150
AND ADDING LOTS 160 THRU 165

Located in the Northeast Quarter of Section 13, T.35, R.24,
and the Northwest Quarter of Section 18, T.35, R.14, S.L.B.#11.

RECORDED # 10917762
STATE OF UTAH, COUNTY OF SALT LAKE, RECORDER AND FILED AT THE
REQUEST OF: First American Title
DATE: 10/17/20 TIME: 2:22 pm BOOK: 2018P PAGE: 106
FEE: \$124.00
Jana Johanson DeWitt
SALT LAKE COUNTY RECORDER

DATE: 6/17/2010 TIME: 2:22 PM BY: JANNI JOHANSON DEPUTY RECORDER
 BOOK: 2010 PAGE: 106
 FILE: 10972752
 SALT LAKE COUNTY RECORDER

PLAT NUMBER	DAYBREAK PARK LOT AREA	DAYBREAK OPEN SPACE LOT AREA	COLLECTOR STREET PARK STRIP AREA	NON-COLLECTOR STREET PARK STRIP AREA	PARK AREA DEDICATED TO CITY	OPEN SPACE AREA DEDICATED TO CITY	TOTAL	NUMBER OF LANES	LINEAR FOOTAGE
△ PLAT 1	2.5723	22.23	2.28	5.23	26.0377	0.00	58.35	SEE AMENDED PLAT 1	
△ PLAT 1 AMENDED	12.61	22.17	2.28	5.23	26.0377	0.00	58.29	13	4,887.83
LOT M-104 AMENDED	0.0000	0.0000	0.00	0.00	0.00	0.00	0.00	0.0	0.00
△ PLAT 2	8.6753	1.0496	1.32	4.74	0.00	0.00	15.7849	SEE AMENDED PLAT 2	
PLAT 2 AMENDED	8.6093	1.0496	1.32	4.74	0.00	0.00	15.7189	21	6,340.29
TOWNEHOME 1 SUB.	0.0000	0.0000	0.00	0.00	0.00	0.00	0.00	0.0	0.00
PLAT 3	2.6437	11.6106	0.32	5.89	0.00	0.00	20.4643	9	2,105.88
△ PLAT 4	0.7252	0.3496	0.24	1.97	0.00	0.00	3.2848	SEE AMENDED PLAT 4	
PLAT 4 AMENDED	0.7593	0.3363	0.24	1.97	0.00	0.00	3.3056	9	4,589.98
CARRIAGE CONDOS	0.0000	0.0000	0.00	0.00	0.00	0.00	0.00	0.0	0.00
△ PLAT 5	2.9994	2.7368	1.18	5.39	0.00	0.00	12.3062	SEE AMENDED PLAT 5	
PLAT 5 AMENDED	5.7505	0.0000	1.18	5.39	0.00	0.00	12.3205	36	10,719.18
PLAT 6	3.3710	31.8148	0.00	3.89	0.00	0.00	39.0758	13	3,532.29
△ PLAT 7	16.3272	7.6526	6.27	5.11	0.00	0.00	35.3598	SEE AMENDED PLAT 7A	
PLAT 3A	1.7360	0.0000	0.10	0.39	0.00	0.00	2.2260	5	1,690.56
PLATS 3B-1 THRU 3B-10	0.0000	0.0000	0.00	0.00	0.00	0.00	0.00	0.0	0.00
CORPORATE CENTER #1	0.0000	0.0000	0.07	0.10	0.00	0.00	0.17	0.0	0.00
PLAT 8	* 13.8622	* 0.0431	0.38	3.77	0.00	0.00	* 18.0553	13	4,227.78
△ PLAT 7A AMENDED	16.3272	7.6526	6.27	5.11	0.00	0.00	35.3598	35	10,037.21
△ EASTLAKE VILLAGE CONDOS	0.0000	0.0000	0.00	0.00	0.00	0.00	0.00	0.0	0.00
△ PLAT 9	17.8005	0.0000	5.04	5.92	0.00	0.00	28.7605	SEE AMENDED PLAT 9A	
△ PLAT 7B AMENDED	14.7624	7.6526	7.83	5.11	0.00	0.00	35.3598	SEE AMENDED PLAT 7A	
VILLAGE CENTER 1A	0.0000	0.0000	0.00	0.00	0.00	0.00	0.00	0.0	0.00
AMENDED EASTLAKE VILLAGE CONDOS	0.0000	0.0000	0.00	0.00	0.00	0.00	0.00	0.0	0.00
PLAT 9A AMENDED	17.8005	0.0000	5.04	5.92	0.00	0.00	28.7605	38	11,087.08
△ AMENDED PLAT 1A	12.61	22.17	2.28	5.23	26.0377	0.00	58.29	SEE AMENDED PLAT 1	
DAYBREAK VIEW PARKWAY SUBDIVISION FROM PLAT A1 TO THE EAST FRONTAGE ROAD	0.0000	0.0000	1.36	0.00	0.00	0.00	* 1.36	0.0	0.00
APARTMENT VENTURE #1	0.0000	0.0000	1.30	1.14	0.00	0.00	* 2.44	0.0	0.00
PLAT 3C	0.0000	0.0000	0.84	0.00	0.00	0.00	0.84	0.0	0.00
DAYBREAK VIEW PARKWAY SUBDIVISION FROM EAST FRONTAGE ROAD TO 1800 SOUTH	0.0000	0.0000	1.11	0.04	0.00	0.00	1.15	0.0	0.00
COMMERCE PARK PLAT 1	0.0000	0.0000	0.19	0.22	0.00	0.00	0.41	0.0	0.00
△ COMMERCE PARK PLAT 2	0.0000	0.0000	0.47	0.00	0.00	0.00	* 0.47	0.0	0.00
PLAT 8A-1	0.0000	0.0000	0.00	0.00	0.00	0.00	0.00	2	740
PLAT 8A-2	0.0000	0.0000	0.00	0.00	0.00	0.00	0.00	0	0
VILLAGE 4A PLAT 1	2,1490	0.0000	1.49	0.00	0.00	0.00	3,6390	7	1,028.00
△ VILLAGE 4A PLAT 2	0.8623	0.0000	0.61	0.00	0.00	0.00	1,4723	4	731.76
PLAT 8A-3	0.0000	0.0000	0.00	0.00	0.00	0.00	0.00	0	0
PLAT 8A-4	0.0000	0.0000	0.00	0.00	0.00	0.00	0.00	0	0
PLAT 7C AMENDED	14.7624	7.3647	7.83	5.11	0.00	0.00	35.3598	35	10,037.21
AMENDED VILLAGE 4A PLAT 2	0.8623	0.0000	0.61	0.00	0.00	0.00	1,4723	3	709.76
EASTLAKE ELEMENTARY SCHOOL	0.0000	0.0000	0.00	0.00	0.00	0.00	0.00	0	0
COUplet LINER PRODUCT #1	0.0000	0.0000	0.00	0.00	0.00	0.00	0.00	0	0
PLAT 3D	0.0138	0.0000	0.12	0.00	0.00	0.00	0.1338	2	449.14
AMENDED PLAT 3B-10	0.0000	0.0000	0.00	0.00	0.00	0.00	0.00	1	33.72
VCI DAYCARE	0.0000	0.0000	0.38	0.04	0.00	0.00	0.42	0	0
VCI CONDO SUBDIVISION	0.0000	0.0000	0.00	0.00	0.00	0.00	0.00	0	0
VILLAGE 4A PLAT 3	2,4531	0.0000	1.56	0.37	0.00	0.00	4,8831	3	1,283.36
UNIVERSITY MEDICAL #1	0.0000	0.0000	0.41	0.00	0.00	0.00	0.41	0	0
△ PLAT 10A	0.766	0.0000	0.64	0.00	0.00	0.00	1.406	2	1,291.32
VCI MULTI FAMILY #1	0.0903	0.0000	0.00	0.00	0.00	0.00	0.0903	3	412.58
AMENDED PLAT 10A	0.766	0.0000	0.64	0.00	0.00	0.00	1.406	2	1,291.32
TOTALS	88.7394	74.3891	29.24	44.21	26.0377	0.0000	252.8712	216	64,188.56

△ INFORMATION COMPILED BY ADDING ACREAGE ON A FINAL PLAT PREPARED BY STANTEC.

△ THESE PLATS WERE NOT ADDED IN THE TOTAL COLUMN AT THE BOTTOM OF THE TABLE. THESE PLATS HAVE BEEN AMENDED AND THE AMENDED PLAT WAS ADDED TO THE TOTAL AT THE BOTTOM OF THE TABLE.

△ THESE PLATS WERE NOT ADDED IN THE TOTAL COLUMN AT THE BOTTOM OF THE TABLE. THIS PLAT HAS BEEN AMENDED THREE TIMES AND ONLY THE LAST AMENDED PLAT (PLAT 7C) WAS ADDED TO THE TOTAL AT THE BOTTOM OF THE TABLE.

△ INFORMATION SHOWN ON A FINAL PLAT PREPARED BY DOMINION.

* THESE NUMBERS ARE CORRECTED FROM THE ORIGINALLY RECORDED PLAT.

Sheet 4 of 4

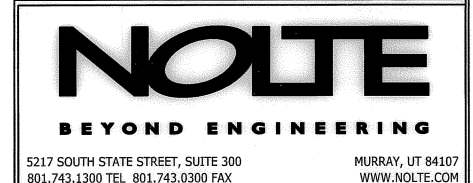

AMENDED KENECOTT DAYBREAK PLAT 10A SUBDIVISION AMENDING LOTS 112, 113, 117, 118, 119, 123, 124, 142, 149 AND 150 AND ADDING LOTS 160 THRU 165

Located in the Northeast Quarter of Section 13, T.35, R.21N, and the Northwest Quarter of Section 18, T.35, R.14N, S.L.B.#11.

RECORDED # 10972752

STATE OF UTAH, COUNTY OF SALT LAKE, RECORDED AND FILED AT THE REQUEST OF: First American Title

DATE: 6/17/2010 TIME: 2:22 pm BOOK: 2010 PAGE: 106

1624.00 Janni Johanson Deputy SALT LAKE COUNTY RECORDER FEB 8